

# Practical Computing

November 1980

Volume 3 Issue 11

**Micro boom: can society survive?**

**Compec Preview**

**Reviews:**

**IBM 5120**

**Acorn Atom**

**Symbolic**

**Maths**

**Controlling model trains**

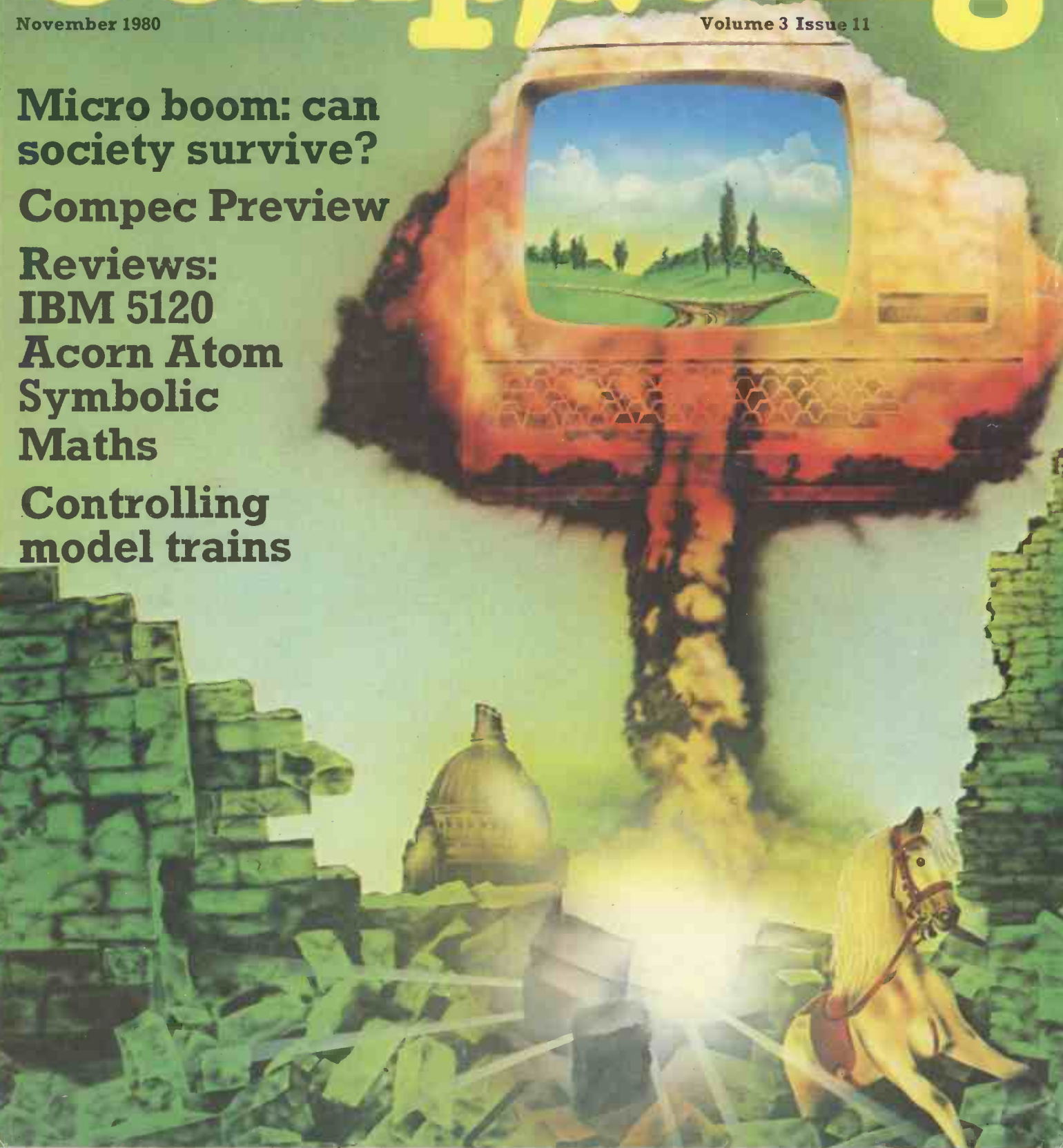

# The best computers PLUS the best service

At MicroCentre, we're concentrating our resources on what we genuinely believe are the very best computers available today. . . . Cromemco computers, naturally. This way we can offer you the best deal possible.

## What we don't do

What we don't do is spread our expertise thinly amongst umpteen different systems, or try to stock every S100 product on the market. We don't claim to offer "impartial" advice on the best buy. And we don't sell from price lists or catalogues.

## The MicroCentre approach

Some micro-computer suppliers work like that, but we don't. Because we realise that when you're buying a computer you want more than the "brochures and boxes" of other suppliers. You want computers



Cromemco Model Z-2H hard disc computer. 10 megabyte hard disc, 2 floppy discs, 7-80 computer and 64K memory. MicroCentre price £5,326.

**... STOP PRESS All Cromemco computers supplied by MicroCentre now have double density disks as standard ...**

That's why we've specialised in Cromemco systems. Not simply because we think Cromemco systems are the best serious computers available at the price.

So when you visit MicroCentre you will find Cromemco systems on permanent

display for demonstration; expect the full range of Cromemco peripherals: single-user and multi-user interactive

documentation, and a complete collection of Cromemco systems software available in the UK.



MicroCentre's Cromemco demonstration room, with the full range of Cromemco computers, peripherals, operating systems and software products on permanent exhibition. Why not pay us a visit? We're only an hour's Shuttle flight from Heathrow!

## Expertise

Expect to find in-depth professional expertise at MicroCentre, the kind that is only acquired by installing Cromemco systems all over Britain. Expect a thorough appreciation of how Cromemco systems can be applied . . . in business, scientific research, industrial engineering, medicine and education.

## Support

Expect to get frank, accurate answers to your questions at MicroCentre. Above all, once you've bought a Cromemco system from us, expect to get a very high standard of technical support with your hardware enhancements and continuing software needs.

At MicroCentre, simply expect the best.

For  **Cromemco... call the experts**

**NOW IN SPACIOUS  
NEW SHOWROOMS**

Tel. 031-556 7354

**MicroCentre**

**STILL IN  
CENTRAL EDINBURGH**

Complete Micro Systems Ltd., 30 Dundas Street, Edinburgh EH3 6JN

● Circle No. 101

Each

# Practical Computing



Mark Wilkinson

A view of society after the micro revolution — page 70.

Editor  
**Peter Laurie**

Staff Writer  
**Duncan Scot**

Production Editor  
**Toby Wolpe**

Editorial Secretary  
**Susie Manning**

Consultants:  
Technical **Nick Hampshire**  
Software **Mike McDonald**  
Videotex **Peter Sommer**

Editorial: 01-261 8752

Advertisement Manager  
**Tom Moloney** 01-261 8107

Advertisement Executives  
**David Lake** 01-261 8056  
**Jeff Weinrich** 01-261 8057

Midlands office:  
**David Harvett** 021-356 4838

Northern office:  
**Ron Southall** 061-872 8861

Advertisement Secretary  
**Stephanie Hill**

Publisher  
**Chris Hipwell**

Published by IPC Electrical Electronic Press Ltd, Dorset House, Stamford Street, London SE1 9LU, tel 01-261 8000, Telex/grams 25137 BISPRSG  
Typesetting and artwork by Bow-Towning Ltd, London EC1  
Printed by Eden Fisher Ltd, Southend-on-Sea

Distributed by IPC Sales and Distribution Ltd, 40 Bowling Green Lane, London EC1R 0NE

Subscriptions: U.K., £8 per annum; Overseas £14 per annum; airmail rates available on application to Subscription Manager, IPC Business Press (S & D) Ltd, Oakfield House, Perrymount Road, Haywards Heath, Sussex RH16 3DH, tel 0444 59188

© IPC Business Press Ltd 1980  
ISSN 0141-5433

Would-be authors are welcome to send articles to the Editor but PC cannot undertake to return them. Payment is at £30 per published page. Programs intended for publication should ideally be justified to 22 or 44 or 66 characters per line.

Submissions should be typed or computer-printed. Hand-written material is liable to delay and error.

Every effort is made to check articles and listings but PC cannot guarantee that programs will run and can accept no responsibility for any errors.

# CONTENTS

41	<b>Editorial</b> / A lurch in the right direction
42	<b>Feedback</b> / Reviews reviewed; upgrading the Pet; ZX-80 heatsink
46	<b>Printout</b> / ZX-80 expansion plans; new hard-disc controller; Micromouse
55	<b>Printout Extra</b> / Compec Preview
60	<b>muMath-79, muSimp-79 and muLisp-79</b> / Tim Robinson looks at three new packages from The Soft Warehouse of Honolulu including the symbolic maths package, muMath-79
62	<b>IBM 5120</b> / The 64K micro from IBM reviewed by Nick Horgan
66	<b>The Acorn Atom</b> / We appraise this low-cost modular system
70	<b>The Micro Revolution</b> / Peter Laurie speculates on the fate of society in the aftermath of the micro boom and we discuss a report on the subject prepared for the Dutch government
76	<b>World Simulation</b> / An adaptation in Basic of the programs used in the controversial Club of Rome report of 1972 which predicted the breakdown of civilisation
84	<b>Larrs' Ghost</b> / Fiction by Chris Kelly
86	<b>Education</b> / Ed James offers a personal view of the probable directions of microcomputing in schools
89	<b>The future of packaged software</b> / Recommendations for packaged programs by Cliff Dilloway
90	<b>Program maintenance</b> / Brian Swindells describes some indispensable design techniques
92	<b>Model trains controlled by micro</b> / An unusual applications project
100	<b>Garbage prevention and destruction</b> / Essential programming skills
102	<b>The Transam Tuscan design story</b> / Part five of Mike Hughes' account of a computer's development
106	<b>Nascom 1</b> / Low-cost memory expansion for this popular machine
109	<b>Z-80 Zodiac</b>
111	<b>ZX-80 Line-up</b>
113	<b>Tandy Forum</b>
115	<b>6502 Special</b>
117	<b>Pet Corner</b>
123	<b>Apple Pie</b>
126	<b>Book Reviews</b>
127	<b>Diary</b>
128	<b>Machine Code</b> / The seventh part of David Peckett's study
135	<b>Apple COS</b> / Part four of Hugh Dobbs' series
139	<b>Software Buyers' Guide</b>
148	<b>The Hexadecimal Kid</b> / Page 2 of the parable in eight virtual pages
	<b>Prestel page number 45631</b> / The Practical Computing Prestel pages

# Now available On Earth



## THE SHARP MZ-80 COMPUTER SYSTEM

Sharp have been associated with many major advances in electronic technology in space and here on Earth. We have introduced the most sophisticated production techniques for electronic circuitry to set world renowned standards of reliability into every product.

That's why the MZ-80K and its range of peripherals is going to change the way you think about microcomputers. The Sharp MZ-80 System now includes the MZ-80K processor backed with the MZ-80FD dual drive, double sided mini-floppy disk unit to give rapid, effective, sequential and random access, to huge amounts of stored information with incredibly fast response times.

Our new MZ-80P3 printer makes a good impression as well. Its fine definition dot matrix

head prints across 80 columns, at 100 characters per second, with full graphics capabilities.

The Sharp MZ-80 System is a new approach to computer applications, and their efficient use by human beings.

Our aim is to make computers and their related equipment relatively simple and therefore better understood and better used by those they are designed to serve.

Whether you are looking for a business system, or a system for educational or personal use—take a look at Sharp, it will change the way you think about computers.



# COMPUTER APPLICATIONS

Send me details of the complete Sharp MZ-80 System and the name and address of my nearest stockist PC11

Name \_\_\_\_\_

Address \_\_\_\_\_

Sharp Electronics (UK) Limited, Sharp House, Thorp Road, Newton Heath, Manchester. M10 9BE Tel: 061-205 2333

• Circle No. 102

The  Cromemco

# Z-2H

THE  
MARKET  
LEADER

**Z-2H**  
*Computer System*

 **Cromemco**

**11 Megabytes of hard disc storage in a fast,  
new, table-top computer.**

- Fast Z80A 4MHz processor
- 11-megabyte hard disc drive
- Two floppy disc drives
- 64K RAM memory
- RS-232 serial interface
- Printer interface
- Extensive software available

Camberley	Microbits, Camberley, Surrey 0276 34044
Cambridge	Cambridge Computer Store, Cambridge 0223 68155
Dublin	Lendac Data Systems Ltd., Dublin 372052
Ilford	The Byte Shop, Ilford, Essex 01-554 2177 also at Tottenham Court Road, London 01-636 0647
Leeds	Holdene Ltd., Leeds 0532 459459 also at Wilmslow, Cheshire 0625 529486
London	Digitus Ltd., London W101-636 0105
Manchester	Computer Workshop, Manchester 061-632 2269 also at West Park, Leeds 0532 788466
Newbury	Newbear Computing Store, Newbury, Berks 0635 30505
Newport	Micromedia Systems, Newport, Gwent 0633 50528
Nottingham	Computerland Ltd., Nottingham 0602 40576 also at Birmingham 021-622 7149; Manchester 061-236 4737; Glasgow 041-332 2468
Sheffield	Hallam Computer Systems, Sheffield 0742 663125
Southampton	Xitan Systems Ltd., Southampton 0703 38740
St. Austell	Benchmark Computer Systems Ltd., St. Austell 0726 61000



**comart specialists in microcomputers**

Comart Ltd., P.O. Box 2, St. Neots, Huntingdon, Cambs, PE19 4NY. Tel: (0480) 215005 Telex: 32514

• Circle No. 103

# The b



TRS-80 Model I  
from £379  
4K Level I  
£559  
16K Level II  
(illustrated).

£559.00\*  
(16K Level II)

**TRS 80 Model I Microcomputer** Here's the push button brain, the entertainer, the tutor, the timesaver. Fun for the children, a helper for the businessman and the teacher, a catalogue for the housewife, an analyser for the investor and an informer for the salesman. Run Maths, English, Chess, Draughts and video game programmes for educational fun. Easy to learn and operate — you can even write your own programmes. Suddenly you have a ready and reliable source of brainpower — put it to work immediately.



**TRS 80 Model I C.P.U.'s** Complete and ready to run from your TV monitor. Just plug in and start computing. The lowest priced 4 K level I CPU contains 4096 bytes of user memory and can be expanded to 16K within the keyboard unit. The 16K level II CPU is a more powerful and flexible version using an additional 12K ROM. Level II also incorporates a calculator style numeric keypad for faster data entry.

# rains.



**TRS 80 Model II Microcomputer** A bigger, more powerful brother to Model I. Designed for more data storage and versatility. Like Model I it is completely modular allowing easy, plug-in expansion. It's available memory will allow maximum use of future languages.

**TRS-80 COMPUTER CENTRES NOW OPEN AT—**  
**Birmingham**—Edgbaston Shopping Precinct, Hagley Road.  
**Bradford**—214, Forster Square.  
**Bristol**—Colston Centre, Colston Avenue.  
**London**—1-2, Seacoal Lane, Ludgate Hill, EC4.  
**Manchester**—30, Market Place, Deansgate.  
**Southampton**—East Street Centre.

**FULL COMPUTER FACILITIES AVAILABLE AT—**  
**Downd**—5, Badminton Road, Downend, Bristol.  
**Leeds**—72, Merrion Centre.  
**Liverpool**—168, Market Way, St. Johns Centre.  
**Wednesbury**—Bilston Road.  
**Wimbledon**—124-126, The Broadway, London, SW19.

\*All prices include VAT.

# IT'S POSSIBLE, ONLY AT Tandy

**Better Equipment. Lower Prices. No Middlemen.**

• Circle No. 104

# *This year the Com a Serio*

*JUST  
Launched.  
Advanced  
Honeywell  
Level 6 Payroll  
Software  
System.*

# **Paymaster**

*Bad news for those of you who were looking forward to Compec '80 for a bit of serious drinking as fussed-over potential customers or for a few pints with your computer chums – this year all the action will be at the*

*Distributed Data Processing Stand No. 6176.*

*On our stand you'll be able to find out about our two very latest Payroll and Disk Drive innovations. Plus talk about our great 'turnkey' range. As a result, this year Compec will be drier. But a lot more interesting too.*

*Honeywell  
Level 6  
'System  
Builder'*



# *...Stand*



# Spec Bar is to have is Rival...

## DDP Products

ITT 2020, Disk Drives, Monitors, Printers,  
OKI 80's, Qumes, Dolphin, Panasonic,  
Honeywell Level 6.

## DDP Services

Payroll, Sales Ledger,  
Purchase Ledger,  
General Ledger,  
Custom Written  
Systems for  
Honeywell, ITT 2020  
or Panasonic.

## DDP Dealer Network

DDP is the largest UK  
distributor of ITT  
2020s, with an  
extensive service and  
engineer back-up.

- ★ 4 Drives running off one card.
- ★ Each drive (double sided) has a capacity of 280K bytes making a total of 1120K bytes.
- ★ 1120K of reliable disk storage in one slot.
- ★ Fast access - motors are continually running under normal operation, so you don't have to wait for motors to get up speed.
- ★ Based on Western Digital chip technology:- the same chip as is used on professional double density 8" drives.
- ★ Power for the disk controller interface is taken from the disk drives own power supply - so you don't have to worry about your computer not being able to cope.
- ★ Fast data transfer - the system can transfer 30K bytes every second to and from your computer.
- ★ Industry standard IBM format. So you have access to a bigger range of software than ever before.
- ★ Switchable Single/Double Density, enabling you to read and write to disks made on many other machines.



2/3/4 Pack  
Disk Drives.  
Available Now.  
ITT/Apple compatible  
- soon other micros.  
Dealer Enquiries  
Welcome.

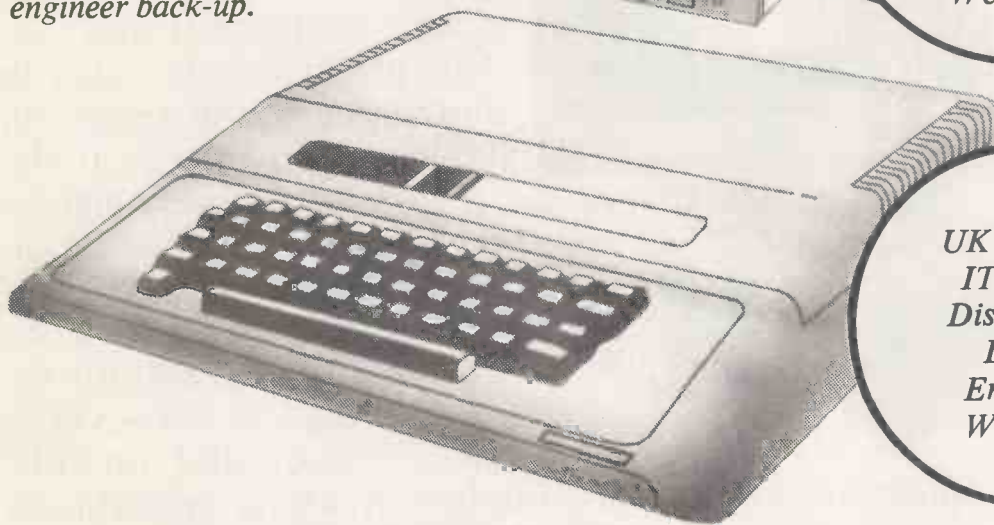

UK's largest  
ITT 2020  
Distributor.  
Dealer  
Enquiries  
Welcome.

# No. 6176



Distributed Data Processing Ltd.

DDP Ltd., 36, Nobel Square, Basildon, Essex. SS13 1LT.

Tel: Basildon (0268) 728484

# NANOCOMPUTER.®

## THE COMPUTER FOR LEARNING ALL ABOUT COMPUTERS.

The microprocessor boom has left in its wake a scarcity of engineers who need to know how to realise to the full the potential of these powerful devices.

SGS-ATES, who have been producing microprocessors longer than any other European manufacturer, are now producing the NANOCOMPUTER, a professional and complete educational microcomputer system specially designed for learning all about microcomputers.

Teaching and Learning: two facets of a single problem.

All learning must be a blend of teaching reinforced with practical training.



The NANOCOMPUTER has been designed to be both tutor and training aid.

It is the result of SGS-ATES many years experience not just in component and systems production but also in the training of both design and production engineers at the

very highest level.

The NANOCOMPUTER, based on the powerful Z80 microprocessor produced by SGS-ATES, is not just a microcomputer but rather a complete, modular educational system designed to grow with the student.

It comes complete with text books in the major European languages, technical manuals and experiment kits.

All these features make the NANO-

*NBZ80-S. CPU board, experiment board, keyboard, card frame/power supply, connecting wires, training books Vol. 1 and 3, Technical Manual.*

COMPUTER an obvious choice not only for supervised courses in schools but also for the engineer who wants to learn in a more personal way all about micro-computers.

**NANO-COMPUTER:**  
a modular system.

The conceptual design of the NANOCOMPUTER, specially created for educational use, combines the exactness of science with the flexibility demanded by the learning process which must be at the same time both theoretical and practical.

The NANO-COMPUTER in its simplest form, NBZ80-B, allows even the newcomer to micro-processors to master programming techniques.

Further up the scale the NBZ80-S introduces him to logical circuits then takes him on to learning how to interface a microprocessor with external devices.

Each learning step taken by the stu-

dent is matched by the NANOCOMPUTER which has been designed for expansion, with a series of upgrade kits, from the simple NBZ80-B through to the NBZ80-S onto a final version with which he can learn not just about programming in the BASIC high-level language but how to use it as an integral part of a hardware system.



**NBZ80-B.** CPU board, keyboard, card frame/power supply, training book Vol. 1, Technical Manual.



**NBZ80-HL.** As NBZ80-S, with 16k bytes of RAM, expansion board with 8k BASIC ROM, video interface board, alphanumeric keyboard, book "BASIC Programming Primer". (TV monitor is optional).

Please send more information about your NANOCOMPUTER.®

PC11

Name \_\_\_\_\_ Address \_\_\_\_\_

City \_\_\_\_\_ Country \_\_\_\_\_

Profession \_\_\_\_\_

Send to: SGS-ATES (UK) Ltd.  
Planar House - Walton Street  
Aylesbury - Bucks.  
Tel. (0296) 5977



SGS-ATES (UK) Ltd. - Planar House - Walton Street - Aylesbury - Bucks - Tel.: (0296) 5977 - Telex 83245. • SPECIALIST MICROPROCESSOR DISTRIBUTORS: Cambridge Microcomputers Ltd. - Cambridge Science Park - Milton Road - Cambridge - Tel. (0223) 314666 • Midwich Computer Company Ltd. - 9 Churchgate Street - Old Harlow - Essex CM17 0JS - Tel. (0279) 412605 • DISTRONIC Ltd. - 50/51, Burnt Mill - Elizabeth Way - Harlow - Essex - Tel. (0279) 32947 - Telex 81387 • Quarndon (Semiconductors) Electronics Ltd. - Slack Lane - Derby DE3 3ED - Tel. (0332) 32651 - Telex 37163.

• Circle No. 106



## SUPERBRAIN™

Intelligent Video Terminal Systems

350K or 700K of Disk Storage

SuperBrain's CP/M operating system boasts an overwhelming amount of available software in BASIC, FORTRAN, COBOL, and APL. Whatever your application . . . General Ledger, Accounts Receivable, Payroll, Inventory or Word Processing, SuperBrain is tops in its class. And the SuperBrain QD boasts the same powerful performance but also features a double-sided drive system to render more than 700K bytes of disk storage and a full 64K of RAM. All standard!



## COMPUSTAR™

MULTI-USER TERMINAL SYSTEM

CompuStar user stations can be configured in a countless number of ways. A series of three intelligent-type terminals are offered. Each is a perfect cosmetic and electrical match to the system. The CompuStar 10 — a 32K programmable RAM-based terminal (expandable to 64K) is just right if your requirement is a data entry or inquiry/response application. And, if your terminal needs are more sophisticated, select either our CompuStar 20 or CompuStar 40 as user stations. Both units offer dual disk storage in addition to the desk system in the CompuStar. The Model 20 features 32K of RAM (expandable to 64K) and 350K of disk storage. The Model 40 comes equipped with 64K of RAM and over 700K of disk storage. But, most importantly, no matter what your investment in hardware, the possibility of obsolescence or incompatibility is completely eliminated since user stations can be configured in any fashion you like — whenever you want — at amazingly low cost!

## DISK STORAGE

Options for the Superbrain and CompuStar Video Terminal

"Backup" for the 20 megabyte Century Data drive is provided via the dual disk system housed in the CompuStar or the SuperBrain. The Control Data CMD Drive features a removable, front-insertable top loading cartridge of 16 megabyte capacity plus a fixed disk capacity of either 16 or 80 megabytes. Each drive is shipped equipped with an EIA and standard 19" rack mounting system and heavy duty chassis slide mechanisms to permit easy accessibility for fast and efficient servicing.

\*\*\*\* WIDELY USED IN UK AND USE \*\*\*\*  
 \*\*\*\* TESTED AND PROVEN \*\*\*\*  
 \*\*\*\* POWER AT YOUR FINGERTIPS \*\*\*\*  
 \*\*\*\* JUST COMPARE THIS LIST \*\*\*\*

NO OTHER PROGRAM IN THE WORLD COMBINES THESE FEATURES IN ONE.  
 many other programmes, LESS INTEGRATED, DO NOT PROVIDE EVEN SOME OF THOSE FEATURES TO BE FOUND ON OUR 'BUS'.  
 1 = TOTAL INTEGRATION OF SALES/PURCHASE/NOMINAL/STOCK/ADDRESSES/ETC.  
 2 = FULL RANDOM ACCESS ENABLES RETRIEVAL OF ANY RECORD IN A SECOND  
 3 = FLEXIBLE PROMPTS ENABLES WORD CHANGE EVEN TO FOREIGN LANGUAGE  
 4 = FILES MAY BE DEFAULT NAMED AND LOCATED FOR FULL DISK USAGE  
 5 = EASY TO USE, MENU DRIVEN, NO SERIOUS NEED OF MANUAL  
 6 = TESTED AND DEBUGGED IN MANY INSTALLATIONS WORLD-WIDE  
 7 = PRICED LESS THAN THE ACQUISITION OF A LIBRARY OF PROGRAMS  
 8 = THE PROGRAM IS \*\*\*TOTALLY\*\*\* IN CORE, MAXIMISING DISK SPACE  
 9 = CORE PROGRAM MEANS THAT DISKS MAY BE INTERCHANGED DURING USE  
 10 = CORE PROGRAM MEANS YOU USE THE FIRST SYSTEM DRIVE YOU PAID FOR  
 11 = NUMEROUS REPORTS MAY BE GENERATED (EG: SALE LEDGERS UP TO 30)  
 12 = INVOICE PRODUCES IMMEDIATE STOCK UPDATE + DOUBLE JOURNAL ENTRY  
 13 = REFERENCE ON INVOICES ENABLE COST CENTRE BUILD-UP ON LEDGERS  
 14 = STOCK VALUATIONS AND RE-ORDER REPORTS EASILY GENERATED  
 15 = BANK BALANCE AND REPORTS PLUS STANDARD MAILING FACILITIES  
 16 = CUSTOMER STATEMENTS AND INVOICES PRINTED ON PLAIN PAPER

WE EXPORT TO ALL COUNTRIES

CALLERS ONLY BY APPOINTMENT.

**IMPORTANT!!! NO COMPUTER HARDWARE IS EVER OF VALUE WITHOUT SOFTWARE; SO WE PROVIDE YOU WITH A STARTING SET OF PROGRAMS \*\*\*\* FREE \*\*\*\*. PURCHASE A SUPERBRAIN AND GET ADDRESS/MAILER (95 POUNDS), STOCK CONTROL (95 POUNDS), DBMS DATABASE MANAGEMENT SYSTEM (195 POUNDS). TOTAL VALUE OF FREE PROGRAMS (385 POUNDS).**

INCLUDES EVERYTHING FROM INVENTORY TO SALES SUMMARY PROMPTS USER AND VALIDATES ENTRIES. MENU DRIVEN  
 BUS VER 3.00 TO VER 9.00 PET AND CP/M  
 APPROXIMATELY 60-100 ENTRIES/INPUTS REQUIRE 2-4 HOURS WEEKLY  
 AND ENTIRE BUSINESS IS UNDER CONTROL

\* PROGRAMS ARE INTEGRATED. . SELECT FUNCTION BY NUMBER. . . . .

- |                                     |  |
|-------------------------------------|--|
| 01 = *ENTER NAMES & ADDRESSES ..... | 13 = *PRINT CUSTOMERS STATEMENTS ..... |
| 02 = *ENTER/PRINT INVOICES .....    | 14 = *PRINT SUPPLIER STATEMENTS .....  |
| 03 = *ENTER PURCHASES .....         | 15 = *PRINT AGENT STATEMENTS .....     |
| 04 = *ENTER A'C RECEIVABLES .....   | 16 = *PRINT TAX STATEMENTS .....       |
| 05 = *ENTER A'C PAYABLES .....      | 17 = GENERAL HELP .....                |
| 06 = *ENTER 'UPDATE INVENTORY ..... | 18 = ALTER VOCABULARIES .....          |
| 07 = ENTER 'UPDATE ORDERS .....     | 19 = PRINT YEAR AUDIT .....            |
| 08 = *ENTER 'UPDATE BANKS .....     | 20 = PRINT PROFIT 'LOSS A'C .....      |
| 09 = *REPORT SALES LEDGER .....     | 21 = ENDMONTH MAINTAINANCE .....       |
| 10 = *REPORT PURCHASE LEDGER .....  | 22 = PRINT CASHFLOW FORECAST .....     |
| 11 = *INCOMPLETE RECORDS .....      | 23 = ENTER PAYROLL (NO RELEASE) .....  |
| 12 = *EXAMINE PRODUCT SALES .....   | 24 = EXIT SYSTEM .....                 |

..... ENTER WHICH ONE?

**DATABASE MANAGEMENT INCLUDES**

\*\*\* FILE CREATE'DELETE'SEARCH. \*\*\* RECORD CREATE'DELETE'SEARCH'4 OPTION PRINT.  
 \*\*\* RECORD SORT ANY FIELD ALPHA OR NUMERIC. \*\*\* INDEX SEARCH OR GENERAL SCAN'PRINT IN ANY FIELD  
 (EG TOWN OR NAME). \*\*\* 4 ARITHMETIC FUNCTIONS TO USE AS CALCULATOR ON LAST 4 FIELDS. \*\*\* AUTO CHECK  
 TO PREVENT DOUBLE ENTRY TO FILE MANAGEMENT SYSTEM, DYNAMICALLY ALLOCATING INFORMATION TO MINIMISE  
 DISK SPACE CONSUMPTION.

VERY FLEXIBLE. EASY TO USE

G.W. COMPUTERS U.K. ARE THE PRODUCERS OF THIS BEAUTIFUL PACKAGE

VER 3.00 (EXC PROG 19;20,22,23) = 475.00, VER 4.00 INCLUDES AUTO STOCK-UPDATE = 575.00,  
 VER 5.00 INCLUDES AUTO BANK UPDATE = 675.00, VER 6.00 IN CORE = 775.00, VER 7.00 (INC 19,20,22,23)  
 NOT YET RELEASED = 875.00, VER 8.00 RANDOM ACCESS = 900.00, VER 9.00 TRANSLATEABLE = 975.00.

+ + + EACH LEVEL OVERRIDES LOWER ONE

**IMPORTANT!!!**

WE ALSO SELL THE HARDWARE FOR THE ABOVE TASKS TO ENABLE THE PURCHASE FROM ONE SOURCE.  
 NOTE THAT A \*\*\* COMPLETE \*\*\* CBM SYSTEM WITH BUS VER 3 IS 2215 POUNDS AND A \*\*\* COMPLETE \*\*\* SUPERBRAIN  
 SYSTEM WITH BUS VER 3 AND DEC PRINTER IS 3345 POUNDS.

PET + PET + PET + PET + PET	SOFTWARE +	SOFTWARE	SUPERBRAIN +	SUPERBRAIN
CBM 3032 32K 595.00	BUS VER 3.00 PET 475.00	475.00	SUPERBRAIN 320K 1695.00	
CBM 3040 DISKS 595.00	BUS VER 4.00 PET 575.00		TWIN Z80 32K + CRT	
CBM 3022 PRINTER 425.00	BUS VER 5.00 PET 675.00		+ 2 D'D-S'S DRIVE	
CBM 8032 32K 875.00	BUS VER 6.00 CP/M 875.00		SUPERBRAIN 320K 1795.00	
CBM 8050 1MEG DISKS 875.00	BUS VER 7.00 CP/M 975.00		TWIN Z80 64K + CRT	
CBM EPSON PRINTER 395.00	BUS VER 8.00 CP/M 1000.00		+ 2 D'D-D'S DRIVE	
CBM MULTI USER 650.00	BUS VER 9.00 CP/M 1075.00		SUPERBRAIN 800K 2195.00	
CBM 3032 + EPSON +	CBM WORDPRO II 75.00		TWIN Z80 64K + CRT	
CBM 3040 + BUS V3 2215.00	CBM WORDPRO III 150.00		+ 2 D'D-D'S DRIVE	
	CPM WORD-STAR 195.00		SUPERBRAIN 2MEG 2795.00	
PRINTERS + PRINTERS + PRINTERS	CPM MBASIC 80 150.00		COMPUSTAR 10 1595.00	
DIABLO 1650 40CPS 2150.00	CPM COBOL 80 320.00		COMPUSTAR 15 1495.00	
DOLPHIN BD80 125CPS 495.00	CPM PASCAL MT 150.00		COMPUSTAR 20 2295.00	
NEC 5510 PRINTER 1695.00	CPM FORTRAN'80 200.00		COMPUSTAR 30 2495.00	
ANADEX 9500 224CPS 975.00	CPM DATASTAR 175.00		COMPUSTAR 40 2795.00	
TELETYPE 43SR 30CPS 875.00	CPM PASCAL-M 250.00		INTERTUBE III 495.00	
DEC-LA34 TRACT 30CP 875.00	CPM BYSTAM S'BRAIN 75.00		EMULATOR 495.00	
NEC-5530PRINTER 1595.00	CPM SUPERSORT 120.00		10 MEG H'DISK 2950.00	
QUME DAISY SPRINT5 1950.00	CPM BASIC COMPILER 190.00		16 MEG (8'8) 3950.00	
TEXAS 810 150CPS 1390.00	CPM DESPOOL 30.00		96 MEG (4DISK) 7950.00	
SPECIALS + SPECIALS + SPECIALS	CPM BYSTAM IMS'N-STAR 75.00		ADDRESS'MAILER 95.00	
N'STAR QUD .7 MEG 1500.00	CPM TEXTWRITER 75.00		STOCK CONTROL 95.00	
IMS 5000 48K D'D 1500.00	CPM POSTMASTER 75.00		DBMS DATABASE 195.00	
COMPUTHINK * 800K * 795.00	CPM SELECTOR 3 180.00		IEEE TO PARALLEL 55.00	
2 WAY CRDLESS PHONE 135.00	CPM CBASIC 75.00		IEEE'RS232 BI'DI 195.00	
TELEPHONE ANSWER 230.00	CPM MACRO 80 75.00		IEEE TO RS232 100.00	
SHUGART SA400 5" DR 135.00	CPM W'STAR M'MERGE 310.00		S'HAND SWTP TERM 100.00	
	BUS MANUAL ***** 9.00		WARRANTY	
			6 MONTH FULL REPAIR ***	

+++++ SPECIAL INSTITUTION AND UNIVERSITY DISCOUNTS +++++  
 STOCK AND COMING ROUND. (BARCLAYCARD WELCOME OTHERWISE CHEQUE WITH ORDER)  
 CONTACT TONY WINTER 01.636.8210  
 89 BEDFORD CT MANS, BEDFORD AVE W.C.1.

# oop Flexible Diskettes

OFFICE DATA PRODUCTS

from...



## SPECIAL OFFER OF oop

Quality Floppy Discs from the World's Largest Manufacturer of this type of Product. Fully Guaranteed.



Extra Special Offer!

84000 Single Sided Single Density 8" Diskette  
26 Sectors, 128 Bytes/Sector **£1.45**

85201 Single Sided Single Density 5 1/4" Diskette  
35 Track Certified. Soft Sector **£1.05**

85501 Double Sided Double Density 5 1/4" Diskette  
35 Track Certified Soft Sector. **£1.59**

*All other configurations available plus all other magnetic media and accessories.*

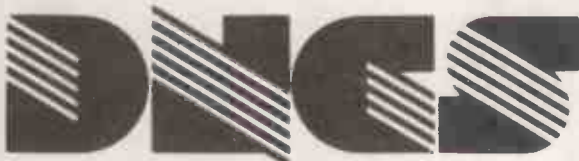

**D.N. COMPUTER SERVICES LTD.,  
WEST CROFT INDUSTRIAL ESTATE,  
MANCHESTER OLD ROAD, MIDDLETON,  
GREATER MANCHESTER.**

Tel: 061-643 0016 Telex: 635091

• Circle No. 108



## CHROMADAPTOR

COMPUTER COLOUR INTERFACE

FOR YOUR PET

### FEATURES

- Sixteen colours available under software control.
- High performance 8MHz UHF modulator for a crisp display.
- Audio output via PET's user port available from Television Speaker.
- High quality 12" x 9" x 3 1/2" metal casing.
- Fully assembled, tested and guaranteed.

### FACILITIES

- Background and Foreground colours are individually selected for every screen character location.
- Allows all of PET's characters and graphics to be programmed in colour.
- Absolute simplicity of operation and programming.
- Simple conversion of existing Black and White programmes to colour.
- Background and/or Foreground colours of total screen area may be changed using only three instructions.
- All facilities available using either BASIC or machine code.
- May be used with old or new ROM PETS.

### DOCUMENTATION

- Full instructions provided.
- Free colour games and demonstration programmes provided.
- All connecting leads included, even a 12 AMP mains plug.
- Rapidly growing colour software library.
- Colour TOOL KIT incorporating additional BASIC instructions available soon.

The all inclusive price for the CHROMADAPTOR is £295.00 plus VAT and £2.50 post and packing.

Also available. MONADAPTER Black & White interface for PETS.

Features: — Choice of black on white or white on black. Sound from T.V. speaker £45.00 + V.A.T.

DEALER ENQUIRIES WELCOME

SADEKTRONICS LTD.

North West House 45 West Street Brighton BN1 1RR

Tel: 0273/29949 Telex: 877159SAD

• Circle No. 109

## Enter the Computer Age video genie system

12K MICROSOFT BASIC  
16K RAM, TV MODULATOR  
INTERNAL CASSETTE



**£330**  
+ VAT

**£395**  
+ VAT

80 Columns  
70 Lines per minute  
Graphics Characters  
Interfaces to most  
machines Tractor or  
friction feed

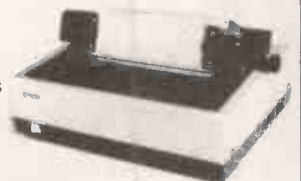

100's of programs available  
TRS-80 level II software  
compatible

Mighty Micro Ltd  
Neptune House  
Sandygate  
Burnley  
Lancs  
Tel: 0282 32209/53629

• Circle No. 110

# CP/M SOFTWARE

from

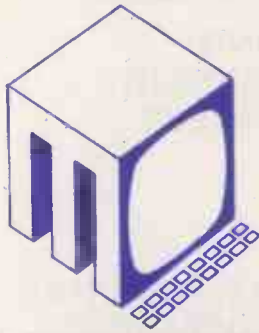

# METROTECH

## WORD PROCESSING

WORD STAR<sup>tm1</sup> is the most complete integrated word processing system ever seen on a micro-computer. In less than six months more than four thousand people all round the world have purchased WORD-STAR. Version 2.0 is now available.

WORD-STAR 2.0	£255
WORD-STAR 2.0 with MAILMERGE	£315

## NEW \* REPORT WRITER \* NEW

Have you seen and liked VISICALC<sup>tm2</sup>? Did you know that similar facilities are now available under CP/M<sup>tm3</sup>? REPORT WRITER will carry out your calculations and produce a columnised report with your headings, totals and summaries. Ideal for financial planning, budgeting and management reporting. Requires 48K, CP/M and Microsoft BASIC

REPORT WRITER	£150
---------------	------

## NEW \* REPORT WRITER \* NEW

## LANGUAGES/UTILITIES

<b>CBASIC II</b> Commercial Disk Extended Basic	£75
<b>SBASIC</b> Compiler Structured Basic	£175
<b>Microsoft BASIC-80</b> Interpreter Version 5 Compiler	£155 £195
<b>SUPERSORT I</b>	£125
<b>WORD-MASTER</b> Superior Text Editor	£75
<b>MET/UTIL</b> advanced CP/M utilities to Backup & Initialise disks and Configure your machine environment	£35
<b>MET/TWAM</b> — Index Sequential Files Access in CBASIC II	£55

## COMMUNICATIONS

**BISYNC-80/3780** and **BISYNC-80/3270** are full function IBM 2780/3780 and 3270 emulators for microcomputers.

**BISYNC-80/3780** gives you a Remote Job Entry terminal for the price of a micro!

**BISYNC-80/3270** combines the local processing power of a micro with a sophisticated screen capability. Make your dumb terminal smart!

**I/O Master** — A superb S100 buffered I/O board which supports 3780 & Teletype communications, plus serial and parallel peripherals.

**MET/TTY** will connect your micro to a timesharing service in simple teletype emulation.

<b>BISYNC-80/3789</b>	£275
<b>BISYNC-80/3270</b>	£275
<b>MET/TTY</b>	£95
<b>I/O Master Board</b>	£225

## DATA MANAGEMENT

**SELECTOR III-C2**  
An easy to use Information Management System in CBASIC II

	£185
--	------

**SELECTOR IV**  
An advanced Information Management System in SBASIC

	£275
--	------

**DATASTAR**  
Powerful data entry, retrieval and update system

	£195
--	------

**Micro Data Base System**  
MDBS is a full network database with many additional options.  
Details and prices available on request.

All software is **ex-stock** and available on standard 8" disks or 5" disks for Cromemco Z2H, North Star Horizon, Vector MZ.

- Add 15% VAT
- Postage and Packing £1 per order
- State which disk type and size
- All orders prepaid
- Manuals available at £15 each

Telephone orders welcome with Access, Barclaycard, American Express or Diners Club  
CALL 0895 57780 or Write to

**METROTECH MAIL ORDER**  
**WATERLOO ROAD**  
**UXBRIDGE**  
**MIDDLESEX UB8 2YW**

enclosing cheque, PO's payable to METROTECH

tm1 WORD-STAR is a trademark of Micropro International Corp.  
tm2 VISICALC is a trademark of Personal Software, Inc  
tm3 CP/M is a trademark of Digital Research

• Circle No. 111

# KGB MICROS LIMITED

THE PROFESSIONAL ORGANISATION OFFERING  
HARDWARE AND SOFTWARE PLUS FULL CLIENT SUPPORT  
WHO WISH TO MAKE YOUR BUSINESS OUR BUSINESS

## SUPERBRAIN™



THE MICRO COMPUTER THAT HAS  
THE BEST PRICE/PERFORMANCE  
RATIO.

**£1495** (64K RAM)

## MICROLINE 80

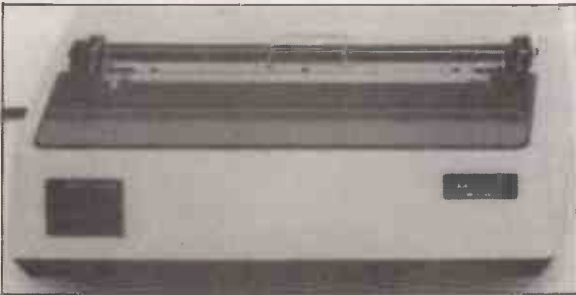

THE EFFICIENT BUSINESS SYSTEM  
SUPERBRAIN

+  
MICROLINE 80 PRINTER

**£1795**

INDIVIDUAL PRICE £500.00

## DIABLO 630

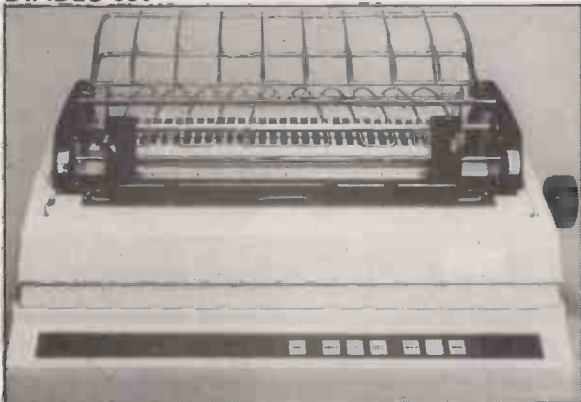

THE COMPLETE WORD PROCESSING  
SYSTEM  
SUPERBRAIN + DIABLO 630 PRINTER  
THE PROVEN 'WORD STAR' PACKAGE

**£2995**

INDIVIDUAL PRICE £1675.00

## SOFTWARE SUPPORT

- \* KGB offer a wide range of standard software — FORTRAN, COBOL, BASIC, PASCAL.
- \* KGB will customise our software packages to meet your unique requirements — Invoicing £95, Sales Ledger £235, Purchase Ledger £235, Nominal Ledger £235, Payroll £335.
- \* KGB will design and implement software to suit your business needs.

**KGB Micros Ltd., 88 High Street, Slough, Berkshire.**  
**Tel: Slough 38581/38319**

Superbrain is the registered trademark of Intertec Data Systems. Prices exc. VAT.

• Circle No. 112

PRACTICAL COMPUTING November 1980



**Mine of Information Limited** **MOI**  
**Microcomputer Consultancy & Booksellers**

*The Mol Top 100 books  
on Microcomputers*

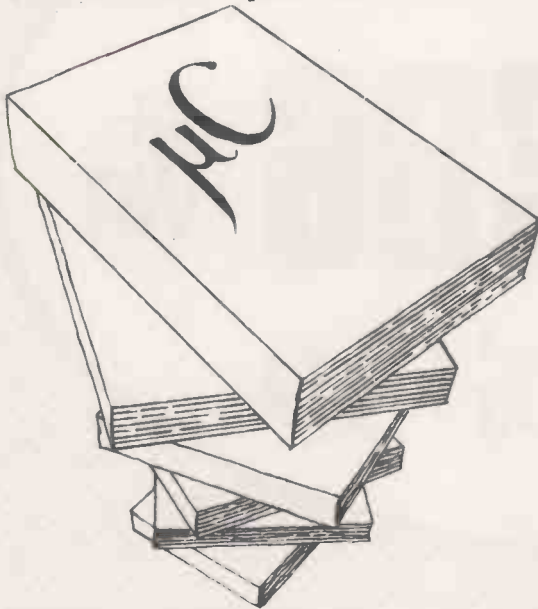

1 Francis Avenue · St Albans · Herts · AL3 6BL · England  
Phone 0727 52801 · Telex 925859

• Circle No. 113



## NASCOM 1 & 2

**Super LIFE (M/C code & Gr.)** — the BEST! — Evolution of a biological colony with 100 by 125 cell array (2/3 or 3/4 options). Use the 21 standard patterns or set individual pixels. Rotate & reflect any pattern. Select from 10 speeds. Evolution can be halted, patterns modified & new speed set. Extensive instructions — overlay technique keeps program within 8K. **SIMPLY FASCINATING!** £8.95

**INVASION EARTH! (NS/G)** — fast M/C code version of the popular arcade game. Four invader types/intelligent homing, exploding, angled, direct, multiple warhead & radio-jamming missiles/40 skill levels. Only £9.95

**STOCK MARKET** Be a high-flying financier! Timely switching between your various shareholdings and interest bearing cash deposits will earn you a fortune in good times and keep you from bankruptcy when things are bad. Highly entertaining. £6.45

**WRITTEN ANY PROGRAMS? WE PAY HANDSOME ROYALTIES!**

SUPER STARTREK (min 16K)	£9.95
Alien Labyrinth (min 16K/NS/G)	£7.95
Renumber	£6.95
Reading Test Cards (NS/G)	£5.95
Spacefighters (NS/G)	£7.95
Sheepdog Trials (NS or NS/G)	£5.95
Death Run (NS/G)	£6.95
Secret Agent (NS/G)	£5.95
Driver (NS/G)	£6.95
Hammurabi	£6.45
Slalom (NS/G)	£5.95
Submarine Chase (G)	£5.45

**PROGRAM COMPETITION.** 3 Xtal BASICS to be won! SAE marked 'Competition' for details.

\*\*NASCOM 1 — Cottis Blandford cassette interface — for N2 format, reliability and fast load. £14.90 or £11.90 with program.

Send Chq/PO + 45p/order P&P  
or See for Catalogue.

(G = graphics, NS = Nas-sys only)  
**TRADE ENQUIRES WELCOME**  
Telephone (0532) 683186

**PROGRAM POWER**  
5 Wensley Road,  
Leeds LS7 2LX

• Circle No. 114

# Z89.



## Altogether a better computer.

All the power and built-in peripherals for business and educational computing in one compact, desk top unit.

The Z89 Series Microcomputer.

Designed and built to the highest specification, the Z89 combines reliability and efficiency with ease of operation. And is backed, of course, by our excellent after sales service.

Features include:

- Z80 CPU
- Built-in floppy Disc with optional dual external drives
- Built-in Z19 VDU
- Up to 65K RAM
- Three serial RS-232 I/O
- Operating systems C/PM & H.DOS.
- Languages: M-Basic, C-Basic, Fortran, Pascal, etc.

And with generous OEM discounts available you can

see why the Z89 is a  
better computer.



# Zenith data systems

For full details about the Z89, complete this coupon and return it to:

Zenith Data Systems Division, Heath Electronics (UK) Ltd.,  
Dept. ( PC11 ), Bristol Road, Gloucester, GL2 6EE.

Name \_\_\_\_\_

Company \_\_\_\_\_

Address \_\_\_\_\_

Z89

• Circle No. 115

WE HAVE ALL THE NEW ATARI®  
VIDEO GAME PROGRAM™  
CARTRIDGES.

**ATARI £86 + VAT**

**SILICA SHOP**

# ELECTRONIC GAMES

## ATARI



SPECIAL PRICE  
**£86 + VAT**

## INTELLIVISION MATTEL



£173.87 + VAT

Available August 1980  
This is the most advanced TV  
game in the world.  
Expandable  
next year into a full  
microcomputer.  
COLOUR CATALOGUE  
AVAILABLE WITH  
DETAILS ON ALL THE  
CARTRIDGES

## CHESS



Send for further details.

### COMPUTERS

NEW RANGE  
AVAILABLE  
AUGUST 1980  
We specialise in  
computer chess  
machines & stock  
over 13 different  
models from  
£20 to £300

## TELETEXT



RADFIN  
TELETEXT  
Add on Adaptor

**£199 + VAT**

## SPACE INVADERS



HAND HELDS - CARTRIDGES  
ATARI: ACETRONIC  
PRINZTRONIC  
RADFIN: DATABASE etc.  
We keep a full range!  
Send for cartridge lists stating which  
machine you own.

## BRIDGE

COMPUTER



- ★ Plays 1/2/3 or 4 Hands
- ★ Problem Mode
- ★ Audio Feedback
- ★ Instant Response
- ★ Auto scorekeeping

## BACKGAMMON

COMPUTERS

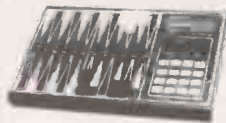

OMAR 1  
OMAR 2  
CHALLENGER  
GAMMONMASTER

From £38 to £108. Send for further details.

## DRAUGHTS

COMPUTER



- ★ Solves Problems
- ★ Rejects illegal moves
- 2 level machine  
£43 + VAT
- 4 level machine  
£77.78 + VAT

## LEISURE

- ★ CHEAP TV GAMES
- ★ TELEPHONE ANSWERING MACHINES
- ★ AUTO DIALERS
- ★ CALCULATORS
- ★ DIGITAL WATCHES
- ★ PRESTEL
- ★ HAND HELD GAMES

27 TUNE  
DOOR  
BELL  
**£17.13**  
+ VAT



**FREE CATALOGUE**

For a free copy  
of our 32 page  
catalogue, send  
a 12p stamp to  
Silica Shop Ltd  
or Telephone  
01-301 1111

MAIL ORDER SERVICE — Free postage & Packing

TELEPHONE & MAIL ORDERS - accepted on  
Access \* Barclaycard \* American Express \* Diners Club

CALLERS WELCOME — at our shop in Welling — Demonstrations daily  
Open from 9am-5pm Mon-Sat (9am-1pm Wed)

GUARANTEE — Full 12 months + After Sales Support

We have comprehensive brochures on all products. Please let us know what you are interested in and we will send you detailed brochures AND our own  
32 page catalogue covering most games on the market!

## SILICA SHOP

SILICA SHOP LTD., Dept. PC9  
102 Bellegrove Road  
Welling, Kent DA16 3QF  
Tel: 01-301 1111

## Original Software for Pet Users

### \*\*\*\* D.S.L. BASIC MANAGER \*\*\*\*

- Stores up to 9 programs simultaneously in RAM
- Call and execute any program under menu control
- No interference with normal Basic operation
- Many additional uses to the ingenious

PRICE — Cassette + Full documentation ..... £12.50

### \*\*\* D.S.L. WORD PROCESSOR \*\*\*

- Full menu control of all functions
- Text entry from keyboard or saved tape file
- Copy/Relocate/Delte/Auto-centering/Justification
- Screen edit/Auto-search replace function
- Print format control via text embedded characters
- Versions for PET or RS232 Printer (Please state type)

PRICE — Cassette + Full Documentation..... £20

IN FERTEC SUPERBRAIN D/D ..... £1995 + VAT  
 INTERTEC SUPERBRAIN Q/D ..... £2400 + VAT  
 MICROSOFT MBASIC 5.1 ..... £150 + VAT

When ordering either program please state whether new or old RAM machine.

Prices include VAT and Postage.

**DRAGON SYSTEMS LIMITED**  
 54 Mansel St., Swansea, W. Glam.

• Circle No. 117

# Master Your Micro FAST with...

Little Genius floppy diskette based courses will teach you, how to use your system and how to realise the full potential of the "Mighty Micro". These fully interactive computer lessons will guide you quickly to a high level of understanding and confidence in your ability to make the most of your microcomputer system.

Courses now available:

- |                            |                          |
|----------------------------|--------------------------|
| - Applesoft BASIC          | - Palsoft BASIC          |
| - Advanced Applesoft BASIC | - Advanced Palsoft BASIC |
| - Using your Apple         | - Using your 2020        |
| - PET BASIC                | - 380Z BASIC             |
| - Advanced PET BASIC       | - Advanced 380Z BASIC    |
| - Using your 380Z          |                          |



## Little Genius!

Each course, comprising a floppy diskette, and starting instructions, costs only £40.00 plus VAT.

SPECIAL "3 in one" OFFER for 3 courses covering the same system only £99.00 plus VAT.

Little Genius courses are available from most computer retail outlets, or direct mail order from:

**LITTLE GENIUS**

Suite 504, Albany House, 324 Regent Street, London W1R 5AA.  
 Telephone: 01-580 6361

• Circle No. 118

# Z19.



## The Intelligent terminal.

The Z19 'intelligent' Video Terminal, from Zenith Data Systems, is ideal for a wide variety of high-speed data handling tasks.

Compatible for use with EIA RS-232 or 20mA current loop, it has all the capabilities and features you'd expect from a top-of-the-line peripheral.

- Z80 Microprocessor based electronics
- Special deflection system for sharp resolution
- Full editing functions, plus user-definable keys
- Reverse video by character
- 24 lines of 80 characters plus 25th user status line
- 5 x 7 Dot matrix (upper case)
- 5 x 9 Dot matrix (lower case)
- 128 characters (95 ASC11 and 33 Graphic)
- ANSI and DEC VT 52 compatible

And there's one feature of the Z19 you wouldn't expect. The price. Just £735, exclusive of VAT and delivery charges.

Generous OEM discounts are available.

**Zenith**  
 data  
 systems



For full details about the Z19, complete this coupon and return it to:

Zenith Data Systems Division, Heath Electronics (UK) Ltd.,  
 Dept. ( PC11 ), Bristol Road, Gloucester, GL2 6EE.

Name \_\_\_\_\_

Company \_\_\_\_\_

Address \_\_\_\_\_

Z19

• Circle No. 119

# ALTOS



## The true multi user computer system

The ALTOS ACS 8000 range of business/scientific micro computers creates a new standard in quality and reliability in high technology micro computers.

### Hard Disk / Multi User Systems

The Winchester hard disk/multi user systems are now available supporting up to 4 simultaneous users and providing a maximum of 58 Megabytes of hard disk data storage.

The systems are truly flexible and allow expansion of the ALTOS floppy disk system to keep pace with the users requirements.

- Still single board, features include
- a high speed I/O section with up to six serial ports and one 8 bit Parallel port
  - up to 208K of on board R.A.M.
  - High speed (4 MHz.) D.M.A. control as standard.

Yes, mini power and at micro cost too.

### Hard Disk Security Back-up

The 17.5 Megabyte funnel tape unit permits selective dumping from the Winchester at a rate of 1 Megabyte per minute.

### Built-in Reliability

The ACS 8000 range are true single board micro computers making them extremely reliable and maintainable. All electronics are socketed for quick replacement. Complete diagnostic utility software for drives and memory is provided.

The board and Shugart floppy disk drives are easily accessible and can be removed in less than ten minutes.

### Quality Software

Unlimited versatility. The ACS 8000 range support the widely accepted CP/M and MP/M operating systems plus basic (Microsoft and CBasic), Cobol, Pascal, and Fortran IV. All available now.

Logitek in conjunction with its own microsoftware house, Interface Software Ltd. of Camberley are able to supply a wide range of proven 'off-the-shelf' business software including general accounting, word processing, stock control, mailing list etc.

There are already over 1000 micro computer installations using this software. A track record which we consider speaks for itself. Why 're-invent the wheel' when there is standard software of this quality available now?

### Communication Software

Two new custom software packages are now available for the Altos Computer System operating with CP/M to enable it to communicate with remote machines over ordinary telephone lines. ASYNCH is an asynchronous package that operates with almost any remote machine. SYNCH is a synchronous package for use with the IBM 3780 protocols.

### Custom Graphics & Scientific Software

A full graphics and scientific package is now available for use for the Altos with FPP.

GRAFLIB is a custom Altos software package containing a complete range of FORTRAN—callable graphics subroutines. It is designed with DRE RG—512 board, or a Tektronix 4000 series graphics terminal. Several multi-colour X-Y plotters are supported allowing hard copy in addition to screen graphics.

### After Sales Support

Logitek are supported by DDT Maintenance Ltd. who provide a nationwide field maintenance service for Altos products and offer the option of maintenance contracts.

### Availability

Logitek carry deep shelf stocks of Altos hardware and compatible peripherals.



# LOGITEK

LOGITEK, E.I.C. Electronics Ltd.

All enquiries to

8-10 Fazakerley St., Chorley,  
Lancs. Tel: 02572 67615/70206

also at

30 Kelvin Ave.,  
Hillington Industrial Estate,  
Glasgow G52 4LH

Logitek are now the exclusive distributors of  
Altos Computer Products for the U.K. and Eire

• Circle No. 120

# THE SHARP MZ-80 COMPUTER SYSTEM

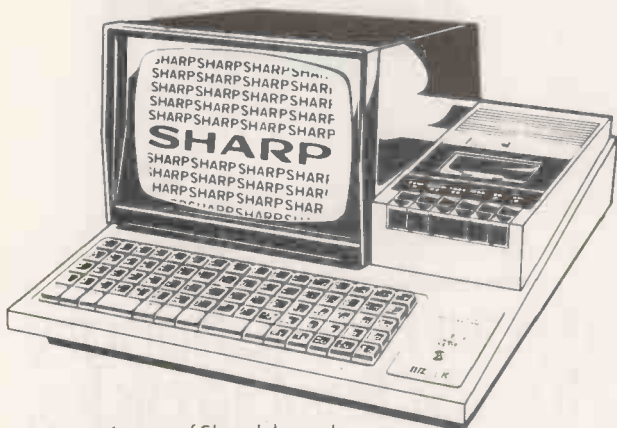

As one of Sharp's largest systems dealers we supply complete MZ-80 systems including FLOPPY DISCS and PRINTERS.

We have considerable experience in implementing SALES, PURCHASE and NOMINAL LEDGERS, PAYROLL, STOCK CONTROL, FOREIGN EXCHANGE and FINANCIAL PROGRAMMES.

Contact us now for details on 01-247 8506.

**SCOPE**

Stone House, Houndsditch Entrance  
128-140 Bishopsgate  
London EC 2M 4HX



• Circle No. 121

## Wilkes Computing Announce The VISUAL 200

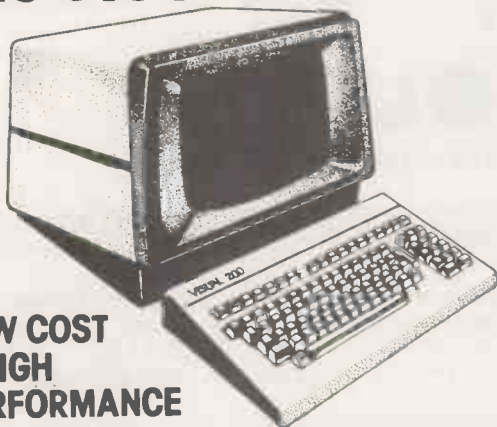

**LOW COST  
- HIGH  
PERFORMANCE**

- Detachable keyboard
- Numerical pad
- Upper & lower case
- Editing
- Smooth scroll
- Cursor addressing
- Printer port
- Many more standard features and options
- Switchable emulations DEC VT52
- Hazeltine 1500
- Lear Siegler ADM3A
- ADDS 520

**Wilkes Computing**

Bush House, 72 Prince Street, Bristol BS1 4HU  
Tel. (0272) 25921 Telex. 449205

• Circle No. 122

# WH14.



## First in line.

If you're looking for an above average line printer at a lower than average price then the WH14 from Zenith Data Systems is your first choice.

Microprocessor controlled, this compact table-top unit can be used with most computers through a standard serial interface. It provides hard-copy output of your programmes as you execute them, plus handy copies of address lines, lists and other programming data for educational or business applications.

Features include:

- 5 x 7 Dot matrix printing
- Clear easy-to-read images
- Upper and lower case characters
- Operator/software selectable line width: 132, 96 and 80 characters per line.
- Sprocket paper feed with adjustable spacing
- Stepper motor feeds allows 6 or 8 lines per inch vertical.
- Form feed operator/computer control
- Microprocessor based electronics

And at £510, exclusive of VAT and delivery charges, the WH14 puts economy first in line too.

Generous OEM discounts are available.

**Zenith  
data  
systems**



For full details of the WH14, complete this coupon and return it to:

Zenith Data Systems Division, Heath Electronics (UK) Ltd., Dept. ( PC11 ), Bristol Road, Gloucester, GL2 6EE.

Name \_\_\_\_\_

Company \_\_\_\_\_

Address \_\_\_\_\_

WH14

• Circle No. 123

## Happy Memories

MEMOREX MINI-FLOPPY DISCS  
IN PLASTIC LIBRARY CASES

Soft sectored for PET, TRS-80 etc:  
£19.95 per 100 including VAT and Postage.

16K Memory Upgrade Kits for TRS-80, APPLE,  
2020, SORCEROR £35 inclusive  
(Stage your application)

RS-232 Plugs and Sockets  
Male: £1.95 Female: £2.25 Hoods 75p

*All prices include VAT. 30p postage on orders  
under £10. Government and Educational  
orders welcome.*



**HAPPY MEMORIES**  
**GLADESTRY**  
**KINGTON**  
**HEREFORDSHIRE**  
**HR5 3NY**  
**TEL: (054 422) 618**



• Circle No. 124

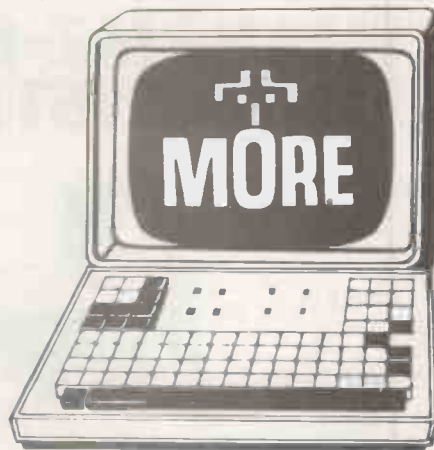

If your PET is hungry  
for 5¼" flexible disks,  
we can feed him.

Control Dataset high quality 5¼" flexible disks  
are readily available at major office equipment  
suppliers. Or you can order  
them direct from us.

For a list of stockists, or  
details of our mail order service,  
contact us at Control Dataset Ltd.,  
P.O. Box 16, Argyle Way, Stevenage  
SG1 2AB, Herts.  
(Tel: 0438-3399)

**CONTROL  
DATASET**  
  
**CONTROL DATA**

• Circle No. 125

**IF . . .** you want the best service  
you need professional advice  
years of experience impress you  
you are trying to find the best computer equipment  
as well as the finest software . . .

# MICROSOLVE

is the Company to contact

We cover a full range of equipment including the **APPLE II** (from £695/16K); the **MICROSTAR** multi-user system (from £4,950) and the powerful **ALPHA MICRO** which will run 1 to 22 terminals — the most cost effective system available today.

WE OFFER A COMPLETE SERVICE which encompasses advice, systems design, sale and installation of computer and peripherals, as well as tailor-made software, where necessary. There are fully documented **ACCOUNTING** and **WORD PROCESSING PACKAGES** etc., for **ACCOUNTANTS, SOLICITORS, MANUFACTURERS, RETAILERS, MEDICAL PRACTITIONERS** in fact all business applications.

ALSO in stock are **PRINTERS, VDUs, CONTINUOUS STATIONERY, DISKETTES, DISK BOXES**, all from the best names in the computer world — **TEXAS, LEAR SEIGLER, TALLY, QUME, PAPER TIGER** etc.

So if you either wish to buy a computer to program yourself or take advantages of our service —  
TELEPHONE NOW FOR AN APPOINTMENT.

MICROSOLVE COMPUTER SERVICES LTD.

3rd Flor (rear), MIDDLESEX HOUSE,  
29-45 High Street, EDGWARE, Middlesex.  
01-951 0218/9/0

(exit 4 M1/20 mins. West End). prices ex. VAT.

• Circle No. 126

# WHERE HAVE THEY GONE?

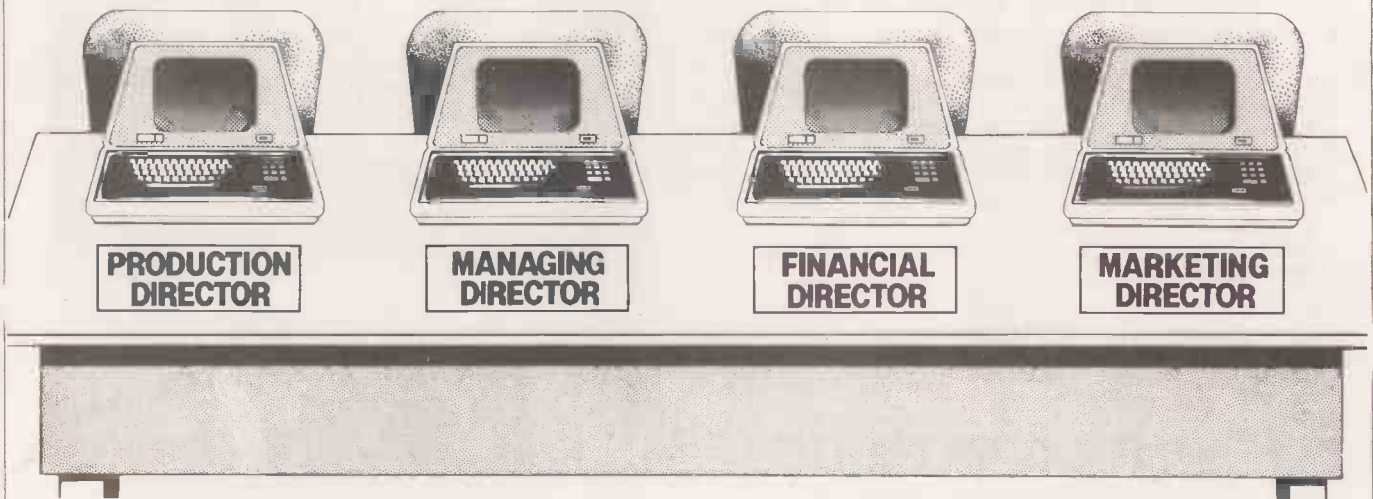

## HOME TO THEIR FAMILIES!

They used to work 80 hours per week ... sometimes more! Just trying to keep in control of their business. They now work about 30 hours per week, have immediate access to information and I am told that they are beginning to enjoy running their businesses!

## HOW DID THEY DO IT?

They talked to me at our City-based management consultancy offices. We procured a multi-terminal, hard disk business microcomputer with magnetic tape, business software and all the support required for less than £20,000.

## THEY WANTED TO TALK TO THEIR COMPUTERS AT HOME!

We saw no problem here, as we recognise that it is quite easy to stay in touch with your computer 24 hours a day wherever you may be — provided that you have access to a telephone. We can make your microcomputers talk to each other or to most other computers.

## COMPLETE PRACTICAL BUSINESS SOLUTIONS

Because we are businessmen, we have probably encountered your problems. If so we have a solution which is flexible, cost-effective and capable of growth just like your business. We arrange a complete package for yourself which you can choose purchase or lease.

## OUR BUSINESS IS BUSINESS; OUR PRODUCT IS COMPUTING

Please contact: K. J. Salmoni on Stand B1 or 01-588-0041 Ext. 62.  
Contour Computer Services Ltd.,  
Boston House,  
63/64 New Broad Street,  
London EC2M 1JJ.

# S100 COLOUR VIEW DATA DISPLAY

- S100 Bus, compatible with Northstar Horizon, Cromemco, Exidy Sorcerer, etc
- Outputs to an ordinary Colour Television UHF/PAL/625L
- Memory mapped for fast update
- Supplied with Driver Software (Z80/8080) which decodes Viewdata ESC Sequences. eg ESC A sets Red Alphanumerics
- Scroll/Page Mode, Visible/Invisible Cursor, Full Cursor Addressing
- Background Colour/Double Height/Separated Graphics/Hold Graphics, and all '76 Codes supported.
- Software available to store and retrieve Pictures from Disc (NSDOS/CP/M)

CD1 PAL or UHF £295.00

CD2 RGB & Syncs £310.00

RGM monitor, cased £318.00

UK customers please add 15% VAT.

## hi-tech electronics

54 High Road, Swaythling, Southampton, SO2 2JF

Telephone (0703) 581555



• Circle No. 128

## Run North Star BASIC under CP/M

'Matchmaker' converts your North Star BASIC Programs and lets you run them under the universal CP/M operating system. There are lots of advantages in doing this: you'll have dynamic file allocation, automatic file creation and extension, and automatic re-use of deleted files, all under the control of the powerful instruction set of the North Star BASIC interpreter with its byte-access or random files, multiline functions, and extensive library of software. 32K memory is all you need. No relocation or modification of BASIC is necessary. Your existing North Star programs will run without modification!

The installation takes about 30 minutes and involves no disassembly or machine coding. Every powerful feature of both systems is maintained with this professional piece of software. The instructions are COMPLETE and very easy to follow.

Please rush me my copy of 'Matchmaker' - price £65 including documentation.

Name \_\_\_\_\_

Address \_\_\_\_\_  
\_\_\_\_\_

Tel. \_\_\_\_\_

 digital devices ltd

134 London Road Southborough, Kent TN4 0PL  
Tel: Tunbridge Wells (0892) 37977-9 or 39546-9

Note: CP/M and North Star are registered trademarks of Digital Research and North Star Computers, respectively.

• Circle No. 129



# PET

8K large keyboard Pet 3008	450.00
16K large keyboard Pet 3016	550.00
32K large keyboard Pet 3032	695.00
32K 80 Column Pet 8032	895.00
8K (Old style 2001)	425.00
3022 Printer	425.00
3040 Disk Unit 340K	695.00
C2N Cassette Deck	55.00
Pet to IEEE Cable	20.00
IEEE to IEEE Cable	25.00

## INTERFACES

Type 1200 I-EEE to RS232 Unidirectional	89.00
Type 1200 as above with upper/lower case conversion switch	109.00
Type 2000 Fully addressable IEEE to RS232 bi-directional	165.00
Type 2000S with upper/lower case conversion switch	185.00
Type C Specific Unidirectional IEEE to RS232 with Pet or Disk Connector	120.00
Type CS as 'C' with upper/lower case conversion switch	132.00

Type 'AP' Addressable Parallel interface for Centronics/Anadex	106.00
Type 'NAP' Non-addressable parallel interface (state Anadex or Centronics)	45.00
Type 'B' Bi-directional IEEE to RS232 V.24 or 20mA loop (state Pet or Disk Connector)	186.00

## PET/MAINFRAME LINKS

Type 2000B with break key for mainframe link and communications modification	190.00
Type 2000BS as above with upper lower case conversion	210.00
RS232 Acoustic Coupler	240.00

## COMPUTHINK

Computhink 400K Disk (complete)	895.00
Computhink 800K Disk (complete)	1145.00
Computhink 1.6 Meg Disk (complete)	1395.00

## MISCELLANEOUS

KIM 1	99.95
6500 Programming Manual	5.00
6500 Hardware Manual	5.00
Pet Revealed	10.00
Programming the 6502-R Zaks	7.95
6502 Applications - R Zaks	7.95

**80-Column Pet**  
Great improvement on the original

- 32K RAM Basic 4.0
- 80 x 25 Screen
- Formatting & Scroll Control
- Split Screen
- Repeat Cursor
- Audible Line Warning
- Ex Stock

**£895.00**  
plus VAT

## Consumables

(All prices exclude VAT)

RIBBONS	
Anadex DP8000	2.50
Pet 3022	2.50
Anadex DP9500	10.00
TTY 43	7.50
Qume Sprint 5 Multistrike Black	4.00
Qume Sprint 5 Multistrike Green, Blue, Red, Brown	5.00
CASSETTES	
C15 x 10s	4.40
PET CONNECTORS	
User Port	1.20
Cassette Port	0.95
Hoods for User Port	2.25

## PAPER

(Add £2.50 securicor per box)

9 1/2" x 11" per box of 2000 sheets (Delivered 17.50 plus VAT)	15.00
12" x 11" per box of 2000 sheets (Delivered 17.50 plus VAT)	15.00
14 1/2" x 11" per box of 2000 sheets (Delivered 17.50 plus VAT)	15.00
8 1/2" rolls (12 x 3 1/2" dia 'A' Quality) (Delivered 20.50 plus VAT)	18.00
8 1/2" rolls (12 x 3 1/2" dia 'B' Quality) (Delivered 17.50 plus VAT)	15.00
Trendcom 100 40 col Paper (per roll)	1.50
Trendcom 200 80 col Paper (per roll)	2.25
SWT PR40 Paper (per roll)	1.00

EX STOCK EXPRESS DELIVERY

for  
**WHAT'S NEW**  
ring  
**051 933 5511**

**Pet Toolkits Down in Price!**  
NOW £44.00 for 32K  
£59.00 for old 8K

## NEW PRODUCT

Toolkit on Stack Rom Switch Board complete with software. Allows both Toolkit and Computhink Disk to be used on the same Pet. Complete with Toolkit and all fittings.

**£79.00** plus VAT

## Verbatim DISKETTES

Examples of prices

525-01	£30 per box
525-10	£30 per box
525-16	£30 per box
550-01	£40 per box
550-10	£40 per box
34-1000	£40 per box

Prices exclusive of 15% VAT.  
We supply all the range.  
Ring us for a price.

# PRINTERS

ANADEX DP8000 80 Col. 93c.p.s.	495.00
ANADEX DP9500 132 Col.	895.00
ANADEX DP9501 132 Col. (16.7 char per inch option)	995.00
Centronics 702 120c.p.s.	1705.00
Texas 810 150c.p.s.	1450.00
Teletype 43 pinfeed	900.00
Teletype 43 Friction	915.00

Teletype 43 Hybrid (pin & friction)	929.00
Teletype 43 £ sign option	40.00
Trendcom Apple A2 interface (text only)	37.50
Trendcom Apple A2G interface (text and graphics)	50.00
Trendcom Pet interface	50.00
Silentype 200 80 Col Thermal (Apple Only)	349.00
OKI Microline 80	499.00
Centronics 737	506.00

Trendcom 100 40 Col Thermal	250.00
Trendcom 200 80 Col Thermal	340.00
Qume Sprint 5 45RO	1995.00
Qume Sprint 5 55RO	2140.00
Qume Sprint 5 45KSR	2248.00
Qume Sprint 5 55KSR	2394.00
Sheet Feeder option for Qume	848.00
Bi-directional Tractor for Qume	175.00

## FOR MORE INFORMATION CUT OUT THIS COUPON

I am interested in particular aspects of microcomputing please send me details as new products appear.

Subjects of interest

- Pet
- Industrial
- Educational
- Consumables
- Apple
- Commercial
- Printers

Name \_\_\_\_\_

Address \_\_\_\_\_

Please send to **STACK COMPUTER SERVICES LTD**  
290-298 Derby Road, Bootle, Liverpool 20.  
Telephone 051-933 5511 for all your enquiries.

Prices exclude VAT.

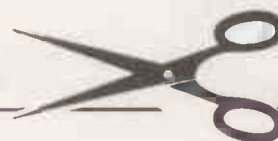

• Circle No. 130

# DATRON of SHEFFIELD

for  
**Cromemco** the ultimate name in micros



DATRON import direct from Cromemco, California.  
 DATRON can supply Nationwide.  
 DATRON can provide maintenance nationally  
 DATRON can give you the realistic prices.  
 DATRON have in stock:-

**SYSTEM 2 64 K £ 2095**

**SYSTEM 3 64 K £ 3746**

**Z-2H HARD DISC 10M £ 5373**

DATRON can supply Systems 2 and 3 with  
 Multi-Tasking facilities.

DATRON easily accessible - in the centre of  
 the country.

Write or telephone for FREE colour brochure on System 3 or Z-2H.  
 We use Cromemco for our own business, why not call in for a demonstration.



**DATRON MICRO CENTRE**  
 DATRON INTERFORM LTD

2 Abbeydale Road, Sheffield S7 1FD.  
 Telephone 0742-585490. Telex 547151.

• Circle No. 131

## INTELLIGENT ARTEFACTS LTD

### DISCOUNT COMPUTER SPECIALISTS

**PET** 8K £425 16K £500 32K £600  
 DISK £650 CASSETTE £50 TOOLKIT £45  
**SUPERPET** 8032 £825 DISK 8050 £825  
**TEXAS** TI99/4 £860 INCLUDING 14"  
 SKANTIC CTV/MONITOR  
**BASE 2** 800B PRINTER £390  
 INC 2K BUFFER, FRICTION + TRACTOR FEED  
**EPSON** TX80B PRINTER £375  
 FULL PET GRAPHICS, IEEE, PARALLEL or RS232  
**NORTH STAR HORIZON** 32K £1450  
 WITH 2 SERIAL + PARALLEL I/O, 4 MHz  
 Z-80 DOS + BASIC  
**SUPERBRAIN** 32K RAM 320K DISK £1500  
 64K 320K DISK £1750 64K 788K DISK £2400  
 WITH INTEGRAL DISK DRIVE + VDU  
 CP/M 2.2, Z-80 4MHz

SEND OR CALL FOR DETAILS.  
 PRICES EXCLUDE VAT.

## INTELLIGENT ARTEFACTS LTD

### DISCOUNT PETS

#### NOW... SUPERPETS!

(IMMEDIATE DELIVERY)

8032 S/PET £825

8000 DISK £825

ALSO... STANDARD PETS

8K £400, 16K £500, 32K £600

C2N £54, DISK £650, TOOLKIT £45

#### INEXPENSIVE PRINTERS

EPSON TX808 (WITH PET GRAPHICS) £350

BASE 2 M800 STM (FRICTION & TRACTOR)

£390

TI 9.9/4 HOME COMPUTER

WITH COLOUR TV £860

NORTH STAR HORIZON 11 £1400

TECHNICAL BACKUP FROM MAPCON  
 ENGINEERS. PRICES ARE EXCLUDING VAT

#### INTELLIGENT ARTEFACTS LTD

Cambridge Road, Orwell, Royston, Herts.  
 Telephone: Arrington 689

• Circle No. 132

# WEST Electronics

3 Budworth Close  
Oxton  
Merseyside  
051-653 8180

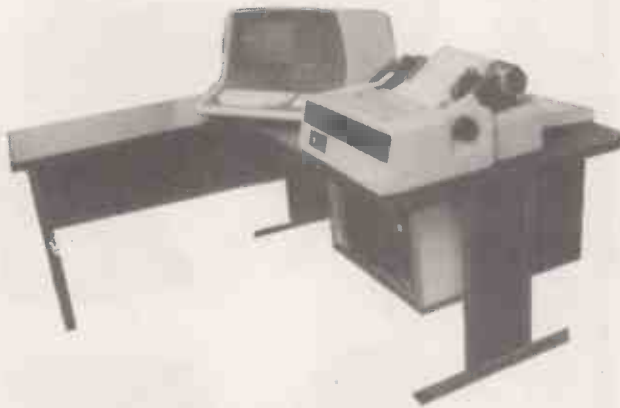

## NEW COMPUTER BREAKTHROUGH

GET IN CONTROL OF YOUR BUSINESS  
WITH THE "WESTON" MICROCOMPUTER

### APPLICATION SOFTWARE:

Nominal Ledger.  
Debtors Ledger.  
Creditors Ledger.  
Payroll.  
Stock Control.  
Reservation Services.

Mailing Lists.  
Sales Forecasts.  
Sales Analysis.  
Word Processing.  
Data Base Management.  
Branch Office Control.

Time Share Terminal.  
Computer Aided Inst & Teaching Aids.  
Product Code Filling.  
Budget Preparation.  
Loan Schemes.  
Time Keeping.

Estate Agent Package.  
Property Management.  
Service Stations.  
Restaurants.  
Hotels and Motels.

### SYSTEM SOFTWARE:

#### Operating System.

CP/M 1.4 CP/M 2.0, CP/M 2.2 MP/M  
OASIS — Multi user, ISAM Files, JCL, Utilities  
SOS, TEMPOS — Multi user — Re-entrant code capabilities.  
OS 2.1 — Conversions.

#### Languages:

BASIC — Ansi Compatible  
DISK BASIC — Random access.  
CP/M Calls.  
Chaining multi user Basic.  
CBASIC.  
BasicE.  
Industrial Basic.  
XY BASIC.  
MBASIC.  
apl — 5100 Compatible.  
COBOL — ISLAM files 1974 Ansi

FORTRAN — Relocatable Code w/library functions.  
PASCAL  
OPUS  
8080 and Z80 ASSEMBLER & DISASSEMBLER.

#### Utilities:

PRINT SPOOLER  
FAST DISK COPY  
COPY FILES  
DISK FORMAT  
TEXT EDITOR (full files)  
MEMORY TEST  
I/O ACCESS  
DISK EXERCISOR  
LINKER LOADER  
RELOCATABLE ASSEMBLER  
PROGRAM RELOCATION  
DYNAMIC Z80/8080 DEBUG

### SPECIFICATION:

Z80 CPU.  
1K EPROM Monitor.  
Up to 8K ROM  
64K RAM on board, Expandable to 256K  
RS-232 Serial Port  
80 char. x 24 line Green Screen VDU  
Upper/lower Case-Reverse, Blink, 1/2 intensity

Up to 16 Dual Sided Disk Drives  
Parallel Printer Port & Auxiliary Keyboard Port  
Disk Controller, Timers, Counters, Calendar Clock, ASYNC,  
BI-SYNC, HDLC, Expansion Bus, Voice Input/Output, Plotters,  
Digitizers, Light Pen, OCR, Acoustic Couplers, Colour,  
Process Interface.

### SPECIAL FEATURES:

Single Board Z80 Based  
1 Megabyte Disk Storage on Twin 5 1/4" Disks  
Programmable DMA Controller  
Programmable Intelligent Bureau Style Keyboard, "QWERTY" numeric  
pad and 26 User Definable Function Keys  
Programmable CRT Controller, Programmable Screen & Character  
Format.

6 Independent Visual Field Attributes.  
11 Visual Character Attributes 4 Cursor Control Modes  
PROGRAMMABLE DMA BURST MODE  
I/O Controller TMS 5501  
Z80 PIO/CTC/SIO  
Optional 40 Megabyte Hard Disk Drive  
Optional D to A Converter and A to D

Fully supported by in house service facilities and software development.  
End User instruction and training.

ALL FOR UNDER £4,000 INCLUDING PRINTER  
Depending upon Software & options required.

DEALER AND TRADE ENQUIRIES WELCOME

• Circle No. 133

**Main London Sorcerer Stockists**  
**EMG 01-688 0088**

We are specialists in complete installations tailor made for your business requirements:

WORD PROCESSING SYSTEM	<b>£1999</b>
ESTATE AGENT SYSTEM	<b>£2999</b>
LEADS AND SALES SYSTEM	<b>£2999</b>
INSURANCE AGENT SYSTEM	<b>£2999</b>
AGENCY SYSTEM	<b>£2999</b>
COMPLETE BUSINESS SYSTEM	<b>£3999</b>

**For the Sorcerer Specialist:**

Sorcerer Systems Desk  
 Mains Stabilisation  
 Cooling Fan  
 Memory Upgrades  
 Servicing Undertaken  
 WP Correspondence Course  
 Link your Sorcerer to another Sorcerer  
 Link your Sorcerer to a Main Frame  
 Full software list on request

**6 COPIES OF SOURCE MAGAZINE ONLY £5**

Write to Dept PC11, EMG Microcomputers Ltd,  
 30 Heathfield Road, Croydon, Surrey.

• Circle No. 134

**Da Vinci Computer Shop**

65, High Street, Edgware, Middx HA8 7DD.

Open  
 Mon-Fri 9-5.30  
 Sat 9.30-5.30

Tel 01-952 0526

**NEW PRICE PCTS**

- CBM 32K £695.00
- CBM 3040 FLOPPY £695.00
- CBM 3022 PRINTER £425.00

**SALES/PURCHASE - LEDGER ACCOUNTING - INCOMPLETE RECORDS**

**WORD PROCESSING - INVOICING - PAYROLL**

**STOCK CONTROL - INFORMATION RETRIEVAL**

**NEW 80 COLUMN SCREEN PET £895.00**

**NEW 1 MEG DISC DRIVE £895.00**

**OS/ME SPRINTS DAISY PRINTER £2115.00**

Da Vinci Computer Shop

**OUR SYSTEMS ARE MASTERPIECES - COME AND SEE THEM!**

• Circle No. 135

**NewBear Computing Store Ltd**



PLEASE ADD V.A.T. TO ALL PRICES.

**MICROCOMPUTING I.C.'S**

MC6800	£6.75
MC6802	£10.50
MC6809	£17.75
MC6810AP	£3.61
MC6821	£4.63
MC6840	£10.50
MC6850	£4.99
MC6852	£4.75
Z80 CPU 2.5 Mhz	£8.99
Z80 CTC 2.5 Mhz	£7.99
Z80 P10 2.5 Mhz	£7.99
Z80-S10/0	£25.57
Z80A CPU 4 Mhz	£10.50
Z80A P10 4 Mhz	£10.00
Z80A CTC 4 Mhz	£10.00
SC/MP 11 (INS806ON)	£11.30
INS8154N	£8.18
6502	£8.99
6522 VIA	£8.14
6532	£9.75
6545 CRT CONTROLLER	£18.50
6551 ACIA	£9.99
8080A	£5.50

**mz-80k**

NBMZ80K MONITOR LISTING	£15.00
NBMZ80K BASIC LISTING	£30.00
NBMZ80K ZEN EDITOR/ASSEMBLER TAPE & MANUAL	£19.50
MZ80K MACHINE CODE TAPE & MANUAL	£22.50
MZ80K ASSEMBLY LANGUAGE TAPE & MANUAL	£45.00
NBMZ80K V24/RS232 PRINTER INTERFACE	£49.50

**DISKS & PRINTER NOW AVAILABLE**  
 A COMPLETE BUSINESS SYSTEM FOR  
 LESS THAN £2000.

SPECTRONICS U.V. EPROM - ERASING LAMPS FROM £45.00.

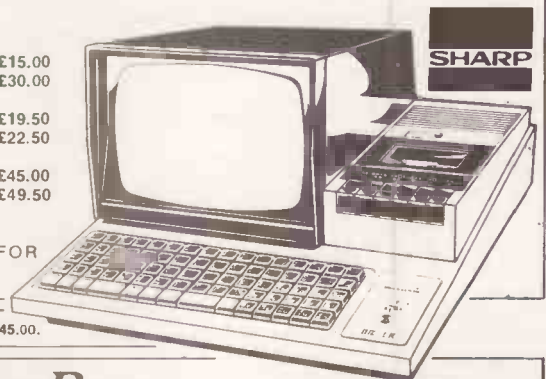

**NEW LOW PRICES!**

C.I.TOH. 8300 R.M. PRINTER

**NewBear**

for the widest selection of computing books  
**NEW BOOK LIST**

**MEMORIES**

4116 (16K DYNAMIC)	£4.50
2716 (INTEL + 5V TYPE)	£12.50
2708	£4.50

**proper 816**

PROFESSIONAL PROM PROGRAMMER  
 FOR 2708/2716/2532  
**PRICES FROM £565.00**  
 SEND FOR FULL SPECIFICATION.



**NEWBEAR COMPUTING STORE LTD, (HEAD OFFICE) 40 BARTHOLOMEW STREET, NEWBURY, BERKS**  
**TELEX 848507 NCS** MAIL ORDER **TEL. (0635) 30505**  
 FIRST FLOOR OFFICES, TIVOLI CENTRE, COVENTRY ROAD, BIRMINGHAM. **TEL. 021 707 7170**  
 220-222 STOCKPORT ROAD, CHEADLE HEATH, STOCKPORT. **TEL. 061-4912290**

**GET A SHARP DEAL FROM NEWBEAR**  
 SEND FOR OUR FREE CATALOGUE

• Circle No. 136

# Quick on the draw!

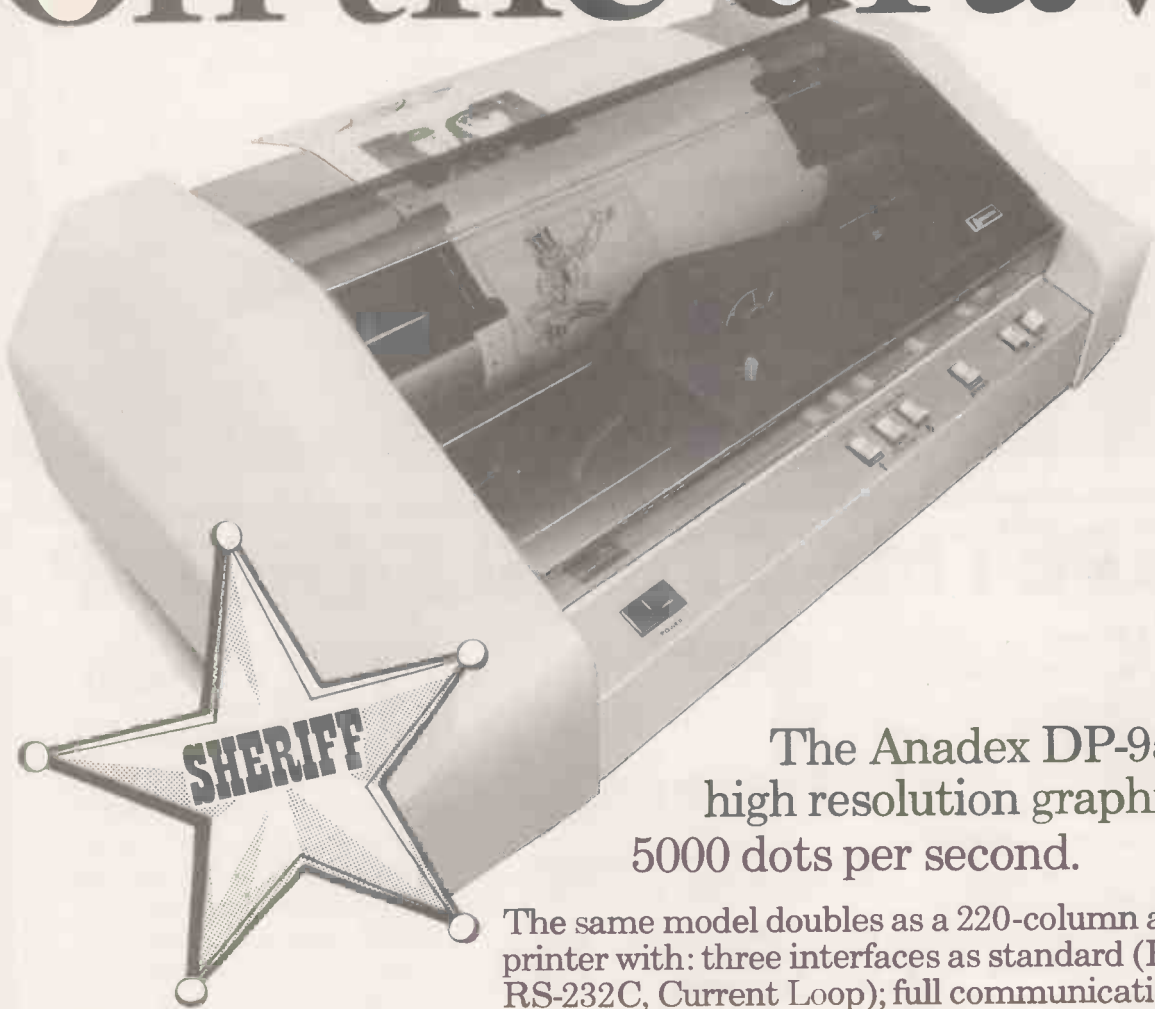

The Anadex DP-9501 draws high resolution graphics at 5000 dots per second.

The same model doubles as a 220-column alphanumeric printer with: three interfaces as standard (Parallel bit, RS-232C, Current Loop); full communication facility; look-ahead bi-directional printing; 96-character ASCII character set including descenders and underlining of all upper and lower case letters; 200 cps printing speed; 'snap-in' replaceable ribbon cartridge and optional 2.7K buffer store.

All for £995 (one off end user price), available ex-stock.

Come and see us at  
'Compec 80' exhibition,  
Olympia, London.



## Anadex Ltd.

Details from Anadex Limited, Dorna House, Guildford Road,  
West End, Woking, Surrey. Telephone (09905) 6333. Telex 858762 Anadex G.

• Circle No. 137

# Printed Continuous Stationery

we can supply printed continuous forms with your company name and logo plus ex-stock single part listing paper in the following sizes:-

depth x width	(in inches)	depth x width
11 x 9¼		13 x 9¼
11 x 9½		8½ x 11½
11 x 10¾		12 x 8½
11 x 9⅞		NEW [ 12 x 9¼ 60 gsm 12 x 9¼ 70 gsm 12 x 9¼ 85 gsm
11 x 8½		
11 x 12		
8½ x 12		

multiples in OTC or NCR are available for prices and details telephone:-

## David Richards 01-520 8624

David Richards (Printers & Distributors) Ltd 61/63, Hoe Street London E17 4SA

• Circle No. 138

# THE PETMASTER SUPERCHIP

JUST LOOK AT WHAT YOU WILL BE ABLE TO DO WHEN YOU PLUG IN YOUR PETMASTER SUPERCHIP.

- Automatic repeat facility on all keys or just insert/delete, space and the cursor movement keys
- Adjustable repeat delay/speed
- Graphics/lower case toggle
- Variable cursor flash speed
- Scroll screen up or down
- Escape from quote mode
- Erase line up to cursor
- Erase line from cursor
- Insert or delete line



ONLY **£45** PLUS VAT

**TOOLKIT COMPATIBLE !**

ADD COUNTLESS NEW FEATURES TO YOUR EXISTING MACHINE :  
Many of the SUPERCHIP's useful functions are similar to those only available on the new 8000 series Superpets. And most may be accessed either from the keyboard or from Basic.

WRITE FOR OUR FREE CATALOGUE

**PLUS**

- SINGLE KEY ENTRY OF 26 OF THE LONGEST AND MOST COMMON BASIC WORDS
- RETRACE FACILITY WHICH ENABLES YOU TO DISPLAY AT ANY TIME THE LAST 10 LINES EXECUTED. OTHERWISE RETRACE IS INVISIBLE TO THE USER :
- 'SHRINK' routine which eliminates REMs and unnecessary spaces from your program
- 'REVERSE' routine which reverses any part of the screen (black/white to white/black)
- 'MOVIT' subroutine for instantaneous transfer of any area of memory

**see what we've added !**

USER-DEFINABLE MESSAGE  
SCROLL WINDOW FACILITY  
USER-DEFINABLE FUNCTION KEYS



## SUPERSOFT

28 Burwood Avenue - Eastcote - Pinner - Middlesex  
Phone 01-866 3326 anytime

# HAL COMPUTERS

**NEW FROM**

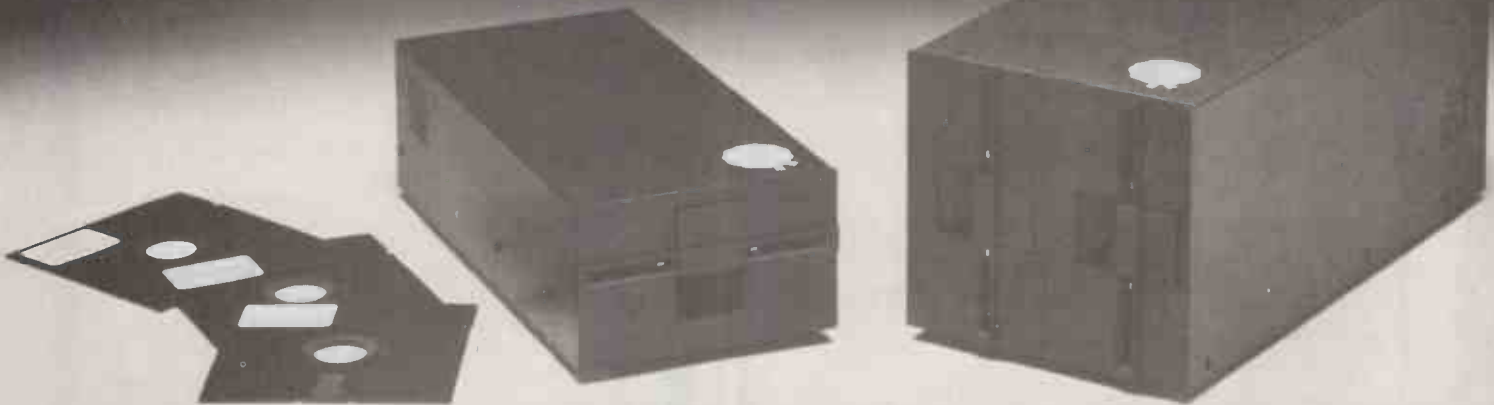

## A complete range of professional floppy disc products from the industry leaders....compatible with TRS 80, Superbrain, Ohio, SWTP, North Star Horizon, Zenith, Cromemco etc.

You can now buy the entire range of Tandon Magnetics high quality, market leading, mini flexible disc drives direct from the exclusive U.K. Distributor.

Tandon drives are available as either the OEM product or as complete packaged units in single or dual drive British manufactured cabinets with high reliability power supply. Complete pre-test and burn in ensures reliability and all drives carry a full 6 months parts and labour warranty.



### BOXED DRIVE PRICES

	Single Box	Dual Box
Single Sided 40 track	£250.00	£430.00
Double Sided 40 track	£330.00	£599.00
Double Sided 80 track	£430.00	£808.00
Dual Boxed Single Sided plus double sided	£549.00	

With Tandon you get 40 or 80 tracks—more capacity and step rates as low as 3 mS track to track—up to ten times the speed of other drives.



**8" DRIVES AVAILABLE - CALL FOR PRICES.**

### CONTROLLERS

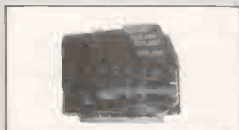

Try us for S-100, Apple, Rockwell, AIM 65, Nascom, Pet.

### HIGHEST QUALITY DISKETTES



As disc capacity has increased, the cost of data stored on diskettes has quadrupled. We recommend only the highest quality discs for use with Tandon

drives and we sell the complete range of Dysan media for 5 1/4" and 8" as well as alignment diskettes. Send for brochure. All in boxes of 10.

\* 40 track

8" SSSD	£34.20
8" DSDD	£48.60
5" SSSD	£26.00
5" DSDD*	£40.00

### STORAGE SYSTEMS



Use our discoflex range of storage wallets and boxes to protect your discs when not in use, or for sending through the post.

5 1/4"	£10.00
8"	£12.00

### POWER SUPPLIES



Our range of Power-One power supplies covers single, dual and triple output not to mention a complete selection of supplies which power all popular floppy disc drives.



### SERVICE AND MAINTENANCE



For the large scale user of 5 1/4" or 8" floppy disc drives, our range of alignment diskettes and service tools are a must. Send for details of our Oasis range of portable dedicated and non-dedicated floppy disc and peripheral test and exerciser systems.

For immediate information on any of these products please contact:

**HAL COMPUTERS LIMITED**

133 Woodham Lane New Haw  
Weybridge Surrey KT15 3NJ  
Tel: Weybridge (0932) 48346/7  
Telex: 8813487

31

# SOFTY Software Development System AND EPROM PROGRAMMER

EX-STOCK

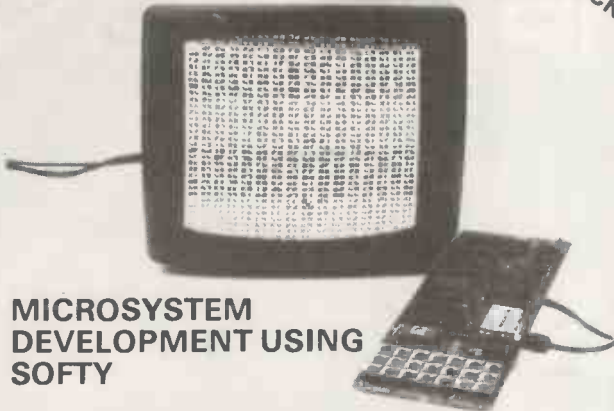

## MICROSYSTEM DEVELOPMENT USING SOFTY

SOFTY is intended for the development of programs which will eventually become software residing in ROM and forming part of a microsystem. During the development stage of a microsystem, SOFTY will be connected in place of the firmware ROM via a ribbon cable, terminated in a 24 pin DIL plug. Data may be entered into the SOFTY RAM via the serial port, parallel port, direct memory access, or the keypad, and manipulated using the assembler key-functions. When the program has been entered, and the internal microprocessor can be 'turned off', and the external microsystem and its resident microprocessor allowed to access and run the program in SOFTY's RAM and/or programming socket. In this way, modification can be made until the required program is complete — the contents of the RAM being clearly visible as a 'page' on TV or monitor, 4 pages are available, 2 of the Data RAM and 2 of the programming socket. In the end, when the program is complete and working, the DIL plus is removed and replaced by an EPROM device programmed by SOFTY. SOFTY is able to program the 2704/2708/2716 family which have 3 voltage rails — To help in the process of program development SOFTY has various assembler key-functions, which include — block shift without overwriting, block store, cursor control, match byte and displacement calculations (for jumps etc). A high speed cassette interface is also provided for storing working programs and useful subroutines. SOFTY Kit-of-parts (including zero insertion force socket for EPROM programmer) Price £115 (inc VAT, p&p). SOFTY built and tested — £138:00 (inc VAT, p&p). Built SOFTY power supply — £23:00 (inc VAT, p&p). Write or telephone for full details.

NEW

**SOFTY CONVERSION CARD —** EX-STOCK  
Enables SOFTY to program the single rail EPROMs 2508, 2758, 2516, (INTEL 2716), 2532. Selection of device type and 1K block are by 4 way pcb slide switches. Programming socket is zero insertion force. Supplied ready built & tested with Dip jumper for connection to SOFTY. £46:00 (inc VAT, p&p).

NEW

**SOFTY PRINTER CARD —** EX-STOCK  
• 40 column electrosensitive printer • 5 x 7 dot matrix  
• software selection of characters per line (1 to 16 bytes)  
• push button printing of EPROM/RAM/intercursor contents  
• Connects to SOFTY card edge • Well documented • Supplied ready built & tested, including power supply, edge connector & paper roll for £156:75 (inc VAT, p&p) Spare paper rolls (28-30metres/roll). Four rolls for £8:00 (inc VAT, p&p).

## MODEL 14 EPROM ERASERS

EX-STOCK

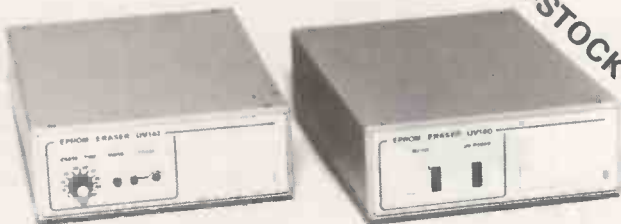

**MODEL UV 141 EPROM ERASER**  
• Fast erase times (typically 20 minutes for 2708 EPROM)  
• 14 EPROM capacity  
• Built-in 5 to 20 minute timer to cater for all EPROMs  
• Safety interlocked to prevent eye and skin damage  
• Convenient slide-tray loading of devices  
• 'MAINS' and 'ERASE' indicators  
• Rugged construction  
• Priced at only £89.70 (inc VAT, p&p)

**MODEL UV 140 EPROM ERASER**  
Similar to Model UV141 but without timer  
Low price at only £70.73 (inc VAT, p&p)  
WRITE OR TELEPHONE FOR FULL DETAILS OR SEND CHEQUES/OFFICIAL COMPANY ORDERS TO:

### GP Industrial Electronics Limited

Skardon Works, Skardon Place, North Hill, Plymouth  
PL4 8HA. Telephone: Plymouth (0752) 28627  
TRADE AND EXPORT ENQUIRIES WELCOME

• Circle No. 141

## PET PRICES DOWN! AT THE ...

**BUSS STOP**

PET		KIM	
8K RAM	£379.00	KIM1	£93.00
16K RAM	£495.00	KIM 3B	£96.95
32K RAM	£625.00	KIM 4	£65.00
DUAL DISK DRIVE	£625.00	PET-IEEE LEAD	£18.75
PRINTER FRIC	£337.00	IEEE-IEEE LEAD	£23.44
PRINTER TRAC	£383.00	PETSOFT TOOL KIT FOR	
EXT CASSETTE	£49.50	16K/32K	£55.00
PET PASCAL COMPILER		8K	£75.00

### NEW SUPER PETS

8032 £895.00  
8050 £895.00

NOW ON DEMO — ORDER NOW TO AVOID DELAY!!

### NASCOM 2 — SYSTEM 80

MOST ITEMS EX-STOCK. PHONE FOR PRICES

### VIDEO GENIE EG 3003 — 16KRAM

FULLY TRS80 LEVEL II COMPATIBLE!

THIS READY TO GO SYSTEM ONLY £289.50

### NEW-DOLPHIN BD80P PRINTER

PET/IEEE, PARALLEL OR RS232 INTERFACE BUILT IN.  
UNBEATABLE BRITISH VALUE AT £525.00

SOFTWARE — 10C12's	£4.50
PETSOFT 10.5 1/4" DISKS	£25.00
BRISTOL 1000 SHEET OF PAPER	£8.40

Software Factory, Commodore Business Software.  
Wide range of books & manuals in stock.  
Phone for keenest O.E.M. and educational user prices.  
Please phone for carriage charges, all prices + VAT  
cheques to Photoacoustics Ltd.

*Riing Rod Eva for details or just call in at the BUSS STOP*  
255a St. Albans Road, Watford, Herts. (entrance in Judge Street)  
Phone: Watford 40698 or Newport Pagnell 610625

• Circle No. 142



Westrex Company Limited  
are pleased to announce  
their re-location to a  
new factory at  
**Bilton Fairway Estate  
Long Drive Greenford  
Middlesex**  
from September 1, 1980

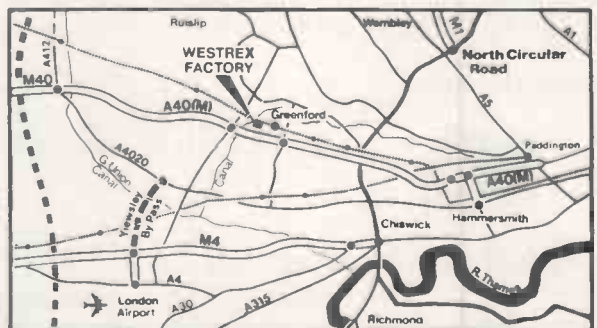

Tel: 01 578 0950 & 578 0957/8/9

• Circle No. 143



# 'TUSCAN' FROM TRANSAM

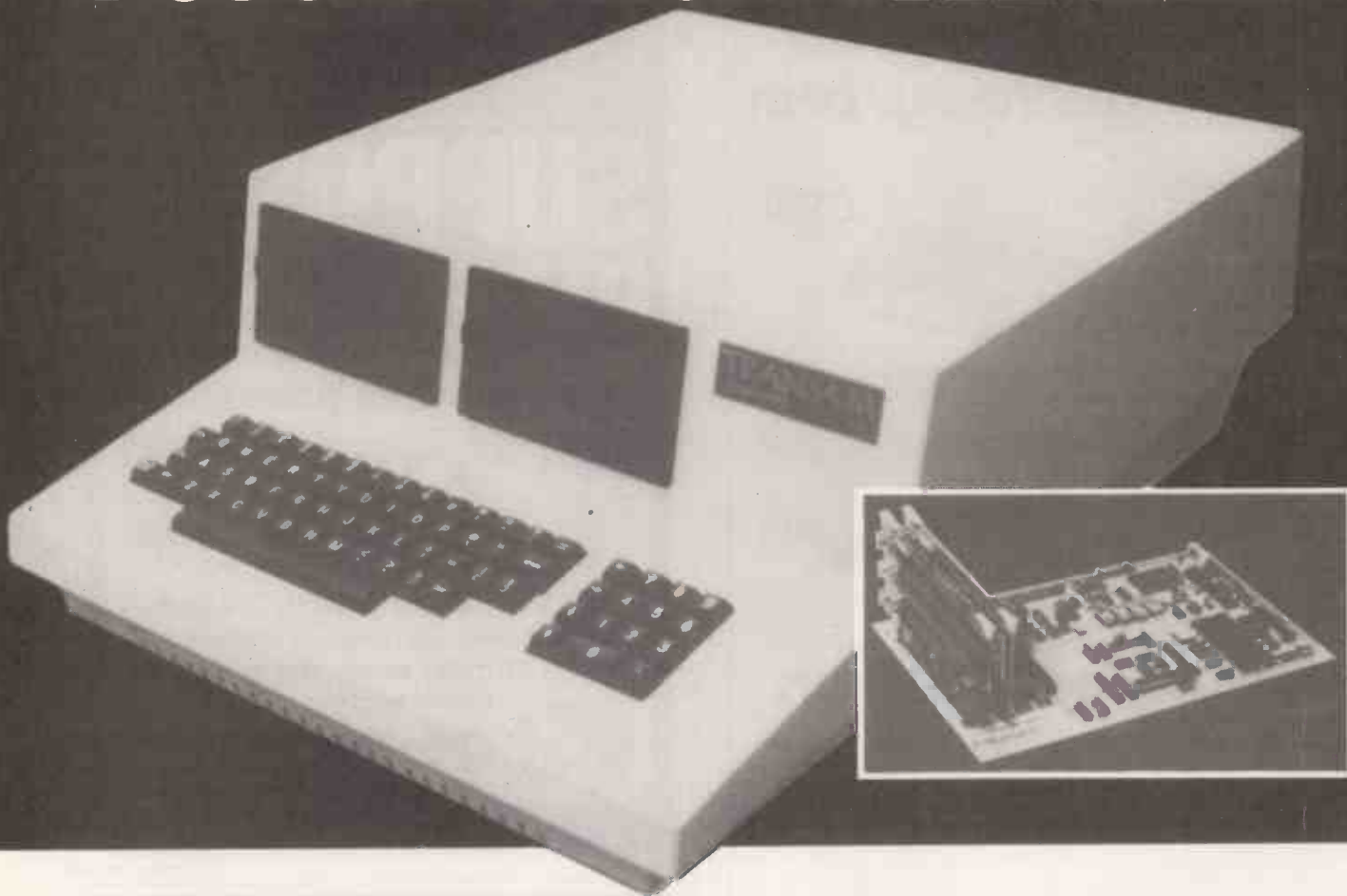

## Take a step up to your next Computer!

### THE CONCEPT

How many ways are there to build an S100 system? Not many, and all expensive. TUSCAN changes all that.

Five S100 boards on one single board — just for starters. Plus five extra slots for future expansion.

What a combination! Z80 and S100 with the TRANSAM total package of system and applications software.

How do we do it? Our prices start at £195 and you can build up in easy stages to a fully CP/M compatible disc based system. Something to think about!

### THE HARDWARE

The first Z80 single board computer with integral S100 expansion. British designed to the new IEEE (8 BIT) S100 specification, the TUSCAN offers total system flexibility. A flexibility available now.

The board holds the equivalent of a Z80 cpu card, 8k ram, 8k rom video and I/O cards with 5 spare S100 expansion slots and offers a price/performance ratio which is hard to beat.

Just compare our price with a commercial S100 ten slot motherboard with this specification.

### THE SOFTWARE

TUSCAN offers the user the choice of system monitor, editor, resident 8k basic, resident Pascal compiler or full CP/M disk operating system. All options are upwards

compatible and fully supported with applications software. Both 5¼" and 8" drives are supported in double density.

### THE PACKAGE

TUSCAN is available in kit form or assembled. With several hardware and software options to suit your requirements and budget. Attractive desk top case also available holds 2 x 5¼" Drives.

# TRANSAM

## NOBODY DOES IT BETTER!

Send to Transam Components Ltd., 59/61 Theobald's Road, London WC1.

I am interested in the TUSCAN Z80 based single board computer with S100 expansion and enclose a S.A.E. for further details.

Name \_\_\_\_\_

Address \_\_\_\_\_  
\_\_\_\_\_

Telephone \_\_\_\_\_

PC11

TRANSAM COMPONENTS LTD., 59/61 THEOBALD'S ROAD, LONDON WC1. TEL: 01-405 5240/2113

• Circle No. 144

# Enter the Computer Age video genie system

12K MICROSOFT BASIC  
16K RAM, TV MODULATOR  
INTERNAL CASSETTE

**£330**  
+ VAT

**£395**  
+ VAT

80 Columns  
70 Lines per minute  
Graphics Characters  
Interfaces to most machines  
Tractor or friction feed



100's of programs available  
TRS-80 level II software  
compatible

#### Dealer List

3 Line Computing  
ABC Supplies  
Advance TV Services  
Allen TV Services  
Amateur Radio Shop  
Arden Data Processing

Beaver Computers  
Blandford Computers  
Briers Bookshop  
Buss Stop

Cambridge Microcomputers  
Catronics  
Cavern Electronics  
Computer Business Systems  
Computer and Chips  
Computerama  
Computopia  
D B Microcomputers  
Derwent Radio  
Eiron Computers  
Eley Electronics  
East Midlands Computer Services  
Emprise Ltd  
G B Organs & TV  
Gemsoft  
Kansas City Systems  
Kays Electronics  
Leisuronic  
Marton Microcomputer Services

Matrix Computer Systems  
Midland Microcomputers  
Microdigital  
Mighty Micro  
Mighty Micro Ltd  
MRS Communications  
Optelco  
C Owens  
Q Tek Systems  
Radio Shack Ltd  
Rebvale Computers  
SMG Microcomputers  
Tryfan Computers  
University Radio Stores  
Ward Electronics  
Watford Electronics

STOP PRESS  
Anglia Computer Centre  
Morrison Computer Centre

Hull 445496  
Levenshulme 061-431-9265  
Shiplay 585333  
Stoke on Trent 616929  
Huddersfield 20774  
Peterboro' 49577  
Leicester 222 55  
Littlehampton 22461  
Blandford 53737  
Middlesbrough 242017  
Watford 40698  
Newport Pagnell 610625  
Cambridge 314666  
Wallington 01-669-6700/1  
Milton Keynes 314925  
Lytham 730033  
St Andrews 72569  
Bath 333232  
Leighton Buzzard 376600  
Limerick 42733  
Scarborough 65996  
Dublin 808575/805045  
Leicester 871522  
Nottingham 267079  
Colchester 865773  
St Saviour Jersey 26788  
Woking 22881  
Chesterfield 850357  
Chesterfield 31696  
Blackpool 27091  
Northampton 890661  
Melton Mowbray 812888  
Stock on Trent 541743  
Beckenham 01-658 7508/7551  
Nottingham 298281  
Liverpool 227-2535  
Basingstoke 56417  
Burnley 32209/53629  
Cardiff 618936/7  
Rayleigh 774089  
Peterlee 865871  
Stevenage 653858  
London NV6 01-624-7174  
Garboldisham 316  
Gravesend 55813  
Bangor 52042  
Nottingham 45466  
Birmingham 021-554-0708  
Watford 40588  
37774

Norwich 29652  
Swansea 795817

**LOWE  
ELECTRONICS**

Bentley Bridge, Chesterfield Road,  
Matlock, Derbyshire. DE4 5LE.

TRADE ENQUIRIES WELCOME



• Circle No. 145



# SUPPORTS PAPER USERS

With sensible prices..

**RULED**  
**14½" x 11" = £6.00**  
INC. P & P

**PLAIN**  
**9½" x 11" = £6.00**  
INC. P & P

For sensible minimums..

of 500 sheets continuous stationery.

Details of other sizes, self adhesive  
labels etc:-



**01-642 8971**

Prices include VAT



• Circle No. 146

## MICROTEK COMPUTER SERVICES

for

**IMS 5000, 8000**

and

## NORTH STAR HORIZON

We have many software packages for these machines, including Stock Control, Accounting, Payroll, Word Processing and Mailing. However, if you are fed-up with looking at standard packages then why not let us design and write a system specially for YOU! If you are interested, contact:

John Rothwell  
on  
Orpington 26803 or write  
to 50 CHISLEHURST ROAD,  
ORPINGTON, KENT

• Circle No. 147

# HOW TO GROW FROM 64K BYTES TO 256K BYTES WITHOUT GETTING BITTEN



Some computer people talk new users into an expensive first system.

Then, as they progress, talk them out of the original system into something more advanced and more expensive.

ADDS don't do this.

Starting with the Multivision desk-top micro-processor with its 64K memory, video terminal and two printer output ports, complete with sophisticated software — you can then add on when you need to, to increase the processor power to 256K bytes which will support 4 VDU's for multi-user operation.

ADDS own engineers and systems analysts are constantly available for support anywhere in the U.K.

ADDS/VANTAGE applications for small businesses are available, and also ADDWORD—ADDS own Word Processing Package.

But don't let the low price fool you. Multivision comes from the world's leading independent terminal producer. A multi-million company able to offer top quality products and back-up services at prices others can't touch.

If you want a real computer at an unreal price, call or write to ADDS (UK) LTD., 137-141 High Street, New Malden, Surrey KT3 4BH. Tel: 01-949 1272 or fill in the coupon below.

## ADDS

ADDS (UK) Ltd

137-141 High Street, New Malden, Surrey KT3 4BH Tel 01-949 1272

Please send me more information about MULTIVISION

Name \_\_\_\_\_ Company \_\_\_\_\_

Position \_\_\_\_\_ Address \_\_\_\_\_

\_\_\_\_\_  
\_\_\_\_\_

**SOMETHING EXTRA IN EVERYTHING WE DO**

• Circle No. 148

# aculab

## floppy tape,

The tape that behaves like a disc,  
For TRS-80 LEVEL II.

Connects directly to TRS-80 Level 2 Keyboard. Operating and file handling software in ROM. 8 commands add 12 powerful functions to Level 2 BASIC. No buttons, switches or volume controls. Full control of all functions from Keyboard or program. Daisy chain multiple drives. Certified digital tape in endless loop cartridges. Reads and writes in FM format at 9000 Baud. Soft sectored with parity and checksum error detection for highly reliable operation—just like discs. Maintains directory with up to 32 files on each tape, tapes may be write-protected. Supports Basic and machine-language program files, memory image and random access data files. 12 character filespecs —: "FILENAME/EXT:d" (d is drive no: 0-7). Automatic keyboard debounce. Full manual with programming examples and useful file-handling routines.

COMMANDS (usually followed with a filespec and possible parameter list).

@SAVE, @LOAD, @RUN —for BASIC programs, machine language programs and memory image files. @GET, @PUT —moves a 256-byte record between a random access file and BASIC's data buffer. @KILL —removes a file from the directory and releases tape sectors for immediate re-use. @LIST —displays file directory along with sector allocation and free sectors. @NEW —formats tape and creates a blank directory.

**Master drive with PSU, Manual and a selection of tapes**

£167-00 +£2-00 pp+vat.

-----  
**Slave drives with PSU** ----- £122-00 +£2-00 pp+vat.

(Export orders pp charged at cost)

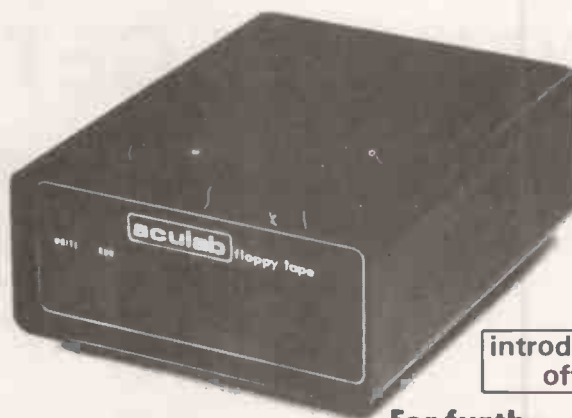

introductory  
offer

For further  
information,  
Telephone  
0525 371393

**aculab** Ltd.  
24 Heath Road,  
Leighton Buzzard,  
Beds. LU7 8AB

• Circle No. 149

## GATE MICROSYSTEMS LIMITED SCOTLAND'S COMPLETE MICROCOMPUTER SERVICE



Announce:

### SUP'R'TERMINAL

SUP'R'TERMINAL IS AN 80 COLUMN BY 24 LINE PLUG-IN  
COMPATIBLE BOARD FOR THE APPLE II COMPUTER

#### SPECIFICATIONS

- 80 Columns by 24 lines, upper and lower case; all 128 ASCII characters.
- Upper and Lower case data entry using the APPLE II keyboard.
- Includes an Upper and lower case 5x8 dot matrix ASCII character set, and inverse alpha characters.
- Character set can be user definable
- Includes VBC™ (video balance circuit) which enables the use of displaying 80 columns on an inexpensive 8 MHz CRT monitor
- Shift Lock Feature
- Works with APPLE PASCAL and APPLE BASIC
- Incorporates PASCAL and BASIC control characters
- ALL monitor-type escapes are valid
- Follows protocols of PASCAL and BASIC operating systems
- Compatible with ALL APPLE II peripherals.
- Effective baud rate greater than 10,000; fast scrolling and clearing
- Synchronous operation with APPLE II
- Can be used with APPLE II communication interface board to act as self contained terminal for time-sharing or other applications.

**£245.00**  
Ex VAT.

**GATE MICROSYSTEMS LIMITED**  
THE NETHERGATE CENTRE, 66 NETHERGATE, DUNDEE  
TEL: (0382) 28194

• Circle No. 150

See us at  
**COMPEC'80**  
 stand 6181  
 Olympia  
 Nov 4-6

# Almarc + Vector Graphic

The complete partnership  
 in Micro computers

### System 2800.

- \* S-100 bus.
- \* Switch-selectable asynchronous baud rates between 110 and 9600 bits/second.
- \* Vector-3 console chassis with 12-inch CRT (18"W x 12 1/2"H x 21"D).
- \* Capacitance Keyboard 6 slot motherboard, and power supply.
- \* Z-80 based single board computer with 1 serial port, 3 8 BIT parallel ports, 3 PROM slots, and

- 1K RAM. Flashwriter II. Video board, 64K dynamic memory board and disc controller. DUALSTOR enclosure with two 8-inch double density disc drives, total disc storage capacity 2.4 m bytes.
- \* Version 4 extended systems monitor on PROM, Vector CP/M 2.2, SCOPE. Screen Oriented Program Editor, full screen dynamic simulating debugger, ZSM Z-80 assembler, Microsoft. BASIC-80 Release 5.



### System 3030.

- \* Vector-3 console chassis with 12-inch CRT (18"W x 12 1/2"H x 21"D), capacitance keyboard, 6-slot S100 motherboard, and power supply.
- \* ZCB Z-80 based single board computer with 1 serial port, 3 parallel ports, 3 PROM slots, and 1K RAM. Flashwriter II Video board, 64K dynamic memory board, floppy disc controller board, Winchester disc interface board, Megastor enclosure with 8-inch Winchester 3-platter hard disc drive, and

- 2 Micropolis Mod II quad density mini-floppy disc drives (20 1/2"W x 7 1/2"H x 16 3/4"D).
- \* Capacity Hard Disc 32 M bytes.
- \* 2 5 1/4" MICROP DISC DRIVES giving 630 Kbytes, Storage Capacity.
- \* Version 4 extended systems monitor on PROM, Vector CP/M 2.2, SCOPE. Screen Oriented Program Editor, full screen dynamic simulating debugger, ZSM Z-80 assembler, Microsoft BASIC-80 Release 5.

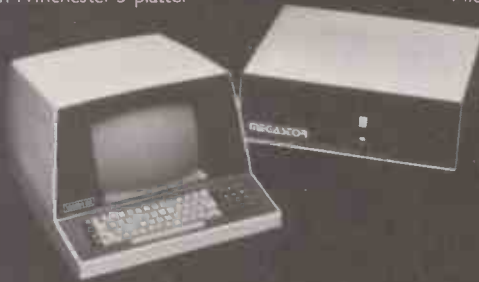

### System 'B'

- \* 64K Bank Selectable Ram (56K available to user).
- \* 3 Serial Ports, 2 Parallel Ports.
- \* Twin Disc Drives, 630K Capacity.
- \* Z-80 CPU, with Fast 4MHZ Clock.
- \* Interrupt Handling on I/O Board.

- \* 18 Slot Motherboard.
- \* Vector Mindless Terminal.
- \* Flashwriter II Video Board (24 x 80).
- \* CP/M 2.2 Operating System.
- Plus Microsoft Version 5 BASIC SCOPE. Screen Oriented Program Editor, Full screen dynamic simulating debugger, ZSM Z-80 Assembler.



At Almarc Data Systems, when you buy Vector Graphic Micro-Computers, you are assured of Almarc's experience of over 350 systems installed throughout the U.K. — plus their back-up of full service facilities carried out by experienced staff. staff.

Almarc are Specialists in Vector Graphic equipment which includes Micro-Computers for research, laboratory work,

word processing, business systems, schools, colleges, universities and industry. Plus an ever growing list of compatible software including Pascal, Fortran, Cobol, APL, Algol, Basic Compiler and others.

We will be pleased to demonstrate how Almarc + Vector Graphic Systems equates to The Complete Partnership in Micro-Computers.

**DATA SYSTEMS LTD**

906 Woodborough Road, Nottingham NG3 5QS.

Tel: (0602) 625035

• Circle No. 151

**SOFTWARE for TRS-80 and Video Genie  
ACULAB FLOPPY TAPE DRIVE and associated software  
VIDEO GENIE 16k microcomputer  
EPSOM TX-80B with TRS-80 or Video Genie interface**

All at sensible prices with very quick delivery

Full information or copy of 'The Kansas Collection' of software upon request



Barclaycard and Trustcard Welcome.

**Kansas**

Unit 3, Sutton Springs Wood, Chesterfield, Derbys. 0246 850357

• Circle No. 152

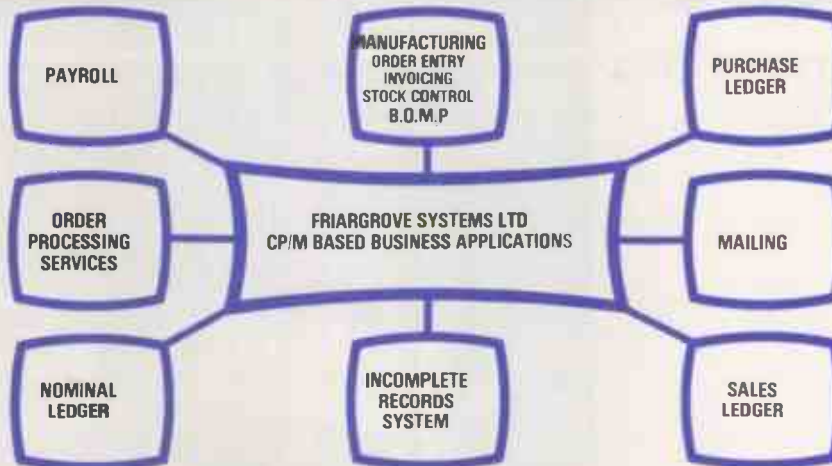

If you wish to buy any of the above systems, please complete the coupon below and return to: Friargrove Systems Ltd, 496 Great West Road, Hounslow, Middx.

	Documentation	✓ Here if required	System	✓ Here if required
Manufacturing Order Processing	£5	<input type="checkbox"/>	£500	<input type="checkbox"/>
Sales Ledger	£5	<input type="checkbox"/>	£350	<input type="checkbox"/>
Purchase Ledger	£5	<input type="checkbox"/>	£350	<input type="checkbox"/>
Nominal Ledger	£5	<input type="checkbox"/>	£500	<input type="checkbox"/>
Payroll	£5	<input type="checkbox"/>	£500	<input type="checkbox"/>
Incomplete Records	£5	<input type="checkbox"/>	£500	<input type="checkbox"/>
Mailing	£5	<input type="checkbox"/>	£250	<input type="checkbox"/>
<b>Total</b>	<u>          </u>		<b>Total</b>	<u>          </u>
<b>Zero VAT</b>	<u>          </u>		<b>15% + VAT</b>	<u>          </u>
<b>Grand Total Cheque enclosed</b>	<b>Total</b>		<b>Total</b>	<u>          </u>

Name .....  
Address .....

*N.B. All Systems Supplied on Single Sector Single Density 8" Floppy Disc*

PC/11/80

• Circle No. 153

## Base 2 MODEL 800MST



ONLY  
300 MST £359 + VAT  
850 MST £399 + VAT

**80 COLUMN HIGH PERFORMANCE IMPACT PRINTER** - suitable for most Micros.  
**JUST LOOK AT THESE STANDARD FEATURES:-**

\*RS-232, 20mA, IEEE 488 and Centronics I/O  
\*15 Baud rates to 9,600 \*100 Chrs. per second -  
Bidirectional \*6 print densities 60, 72, 80, 96,  
120 or 132 Chr/line \*Self test switch \*96 Chrs.  
ASC II Standard \*Auxilliary User Defined-Ch.  
set \*Tractor and fast paper feed/graphics  
\*2k Buffer \*Accepts 8½" max. paper pressure  
feed and 9½" max. paper tractor feed.  
Model 850 - utilises Fifo, 125cps.

## Oki Microline 80



Small, light,  
quiet matrix  
printer.

40, 80 or  
132 cols.

6 or 8 lines per inch.

96 ASC II + 64 graphics character set  
with Centronics compatible interface

£425 + VAT  
RS232 version available.

## Axiom

VIDEO  
PRINTER

Composite Video  
I/P or separate  
Video or sync.

£790 + VAT

The EX-850 Video Printer sets new standards for flexibility in low cost printing. By using a unique video controller, the EX-850 dispenses with the need for any interfacing between the user's CRT display/terminal and printer.

## Epson MX 80

— the worlds first printer  
with disposable print head

\*9x9 dot matrix \*Logic Seeking \*Bi-directional  
\*96 ASCII Characters \*64 Graphics and 8  
International Characters \*Centronics I/P with  
optional RS232 and IEEE 488 \*Four print  
densities 40, 80, 66 or 132 columns \*Multiple  
type founts \*Self Test \*Self Diagnostics  
\*Buzzer for end of paper and bell code error

Introductory price:- ONLY £399 + VAT

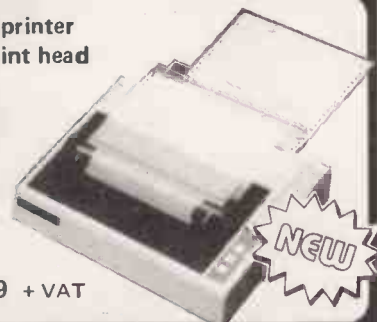

## Mauro

MP-250  
GRAPHIC  
PLOTTER

£499 + VAT



Ideal for educational, hobby and industrial use. Plots on standard paper sheet size up to 11" x 17". Plotting speed 2.5" per sec. Optional I/P RS232 Direct Apple or TRS80 interface.

**FREE WITH EVERY  
PRINTER ORDER**

**A ZEMCO 2T3  
DRIVING COMPUTER  
worth £89 inc.**

Offer available whilst stocks last

THE  
NEW

## Anadex DP9500

A professional  
printer

£895 + VAT



\*Bi-directional printing \*up to 220 chs/  
line with 4 print densities \*500 chr buffer  
\*RS232C & Centronics Parallel interface  
built in \*Full software control of matrix  
needles allowing graphics capability \*200  
chs/sec \*Adjustable width tractor feed

LOW COST BUSINESS/PROFESSIONAL USE  
— HEAVY DUTY

## Anacom 150

150 CPS, 15" carriage, dot  
matrix printer

- an unbelievable

£799 +VAT

The ANACOM 150 is a highly  
dependable receive only printing  
terminal.

It combines the size and  
robustness of Qume/NEC with  
price of matrix printers



The features include:

- \*150 characters per second
- \*9 x 9 dot matrix
- \*10 characters per inch horizontal
- \*6 or 8 lines per inch vertical.
- \*136 columns, 13.6" line length
- \*94 ASCII Characters
- \*Upper and lower case with decs.
- \*Logic Seeking

- \*Double width chrs. programmable
- \*1.5" to 15" wide paper
- \*Programmable top of form feed
- \*Original + 4 copies
- \*Centronics and/or RS232  
Interface 110-9600 baud  
256 character buffer

## NEC Spinwriter

- for the  
professional  
word processing  
system

£1495 + VAT

Model 5510 - RS232, Model Centronics  
8bit par. NEC's high quality printer uses a print  
"thimble" that has less diam. and inertia than a  
daisy wheel. Giving a quieter, faster more reliable  
printer that can cope with plotting and printing  
(128 ASCII chs.) with up to 5 copies, friction or  
tractor fed. 55Chrs/sec.

## Qume Sprint 5

- Daisywheel  
quality  
printer.



50 different type  
styles including APL, Scientific symbols  
and International character sets.  
43 Qume defined commands for oper-  
ating control. Built in diagnostics.  
Serial or parallel. £1595 + VAT

FULL SERVICE BACKUP - FULL DETAILS ON REQUEST INCLUDING PRINTOUT  
Please add V.A.T. at 15%. Carriage extra, will advise at time of order. Official orders welcome.

61 NEW MARKET SQUARE, BASINGSTOKE, HAMPSHIRE. RG21 1HWG

Telephone: Basingstoke (0256) 56468 and 56417 Telex: 858715

also in association with O.S.I. COMPUTERS, ESHER, SURREY.

Telephone: 01-786 2071 and 0372 62072

Buy in confidence. If on receipt of your order the goods do not meet with your  
satisfaction, return within 7 days for full refund. Credit facilities arranged

DISCOUNTS: Attractive discounts for OEM, Educational & Dealers for quantity

# Mighty Micro

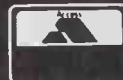

• Circle No. 154

# If only buying a microcomputer was as simple as using one

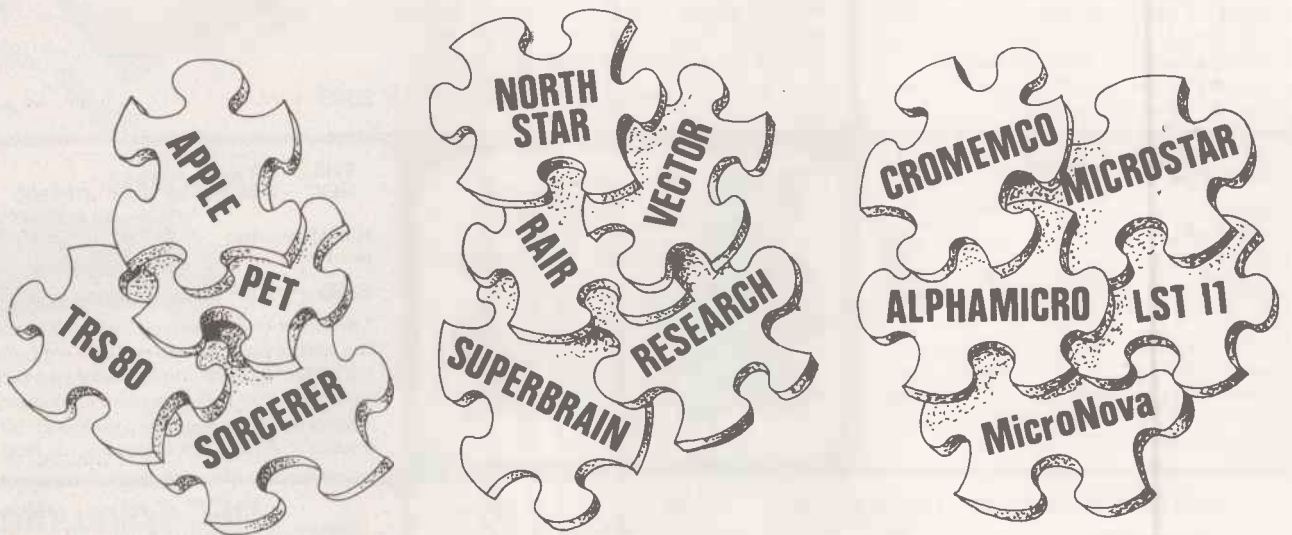

With so many micros to choose from, how do you select the best to meet your needs?

Just look at the advertisements in this magazine. When can you find time to digest them all?

There are millions of chips, thousands of boards and hundreds of peripherals, software systems and application packages. How do you pick the right ones to meet your requirements?

And put them together? And make them work? And add the specials you want?

At Digitus we have computer professionals working full-time putting systems together. Absorbing information. Testing equipment and software. Writing programs. Training users.

At one stop you can commission a complete system to fit your requirements.

Last year we supplied systems for: number processing, word processing, data processing,

graphics and machine control. Advised accountants, surveyors, archaeologists and engineers. Helped DP departments and small business men. Developed software for personnel, incomplete records, order processing, business games, linear programming, process control and terminal emulation. And were retained by other computer companies to advise on micros.

This year we can put even more experience to work so that you can benefit from micro technology ... in comfort.

Come and see us. Spend a few hours discussing your requirements. Attend a training course. Select a machine. Test drive some software.

Solve the micro puzzle. Buy an operational system that fits your needs.

Call for an appointment with one of our consultants.

## Digitus

Alan C. Wood Digitus Limited 9 Macklin Street Covent Garden London WC2 Tel: 01-405 6761

• Circle No. 155



# A lurch in the right direction

THE LONG struggle to make the world with problems on its mind take micros seriously took another lurch forward recently with the publication by the British Medical Association of its report, *Computing in General Practice*. This substantial tome was prepared by Scicon with the guidance of a joint BMA-Scicon steering committee.

It seems to us that this report is newsworthy and commendable for one simple reason: it is the first time that any Establishment body has accepted that microcomputers — as distinct from microprocessors in industrial-control applications — are now a serious tool for professional people. One must add that the report does not go overboard. It is sensible and conservative — indeed, in our opinion rather too conservative at one point — and plots an achievable program to apply micros in the doctor's surgery.

The GP's surgery is in many ways an admirable exemplar of the amorphous small-business application. The doctor has a good deal of data to record; a practice with 15,000 patients would need about 2.5MB. He has to record the salient facts about his patients, their medical problems and to keep track of visits.

He also needs to monitor patients for recall with problems which need regular treatment. He needs to control the issue of repeat prescriptions. He is paid in rather odd ways by the NHS — a visit by a lady over 65 with a wooden leg earns him a set figure. Many GPs do not claim all the income to which they are entitled because of the difficulty of going back through the patient notes. He has staff to pay and books to keep, just like any other small business. He has to arrange appointments and record the results of consultations with patients.

That data could lead to useful statistical surveys of clinical problems in the practice. He needs timely data from outside the practice; information on new drugs and, in particular, notice of undesirable side-effects, particularly if prescribed with certain other drugs. He needs to know about vaccination regulations which can change suddenly.

If he supplies medicines to his patients, he needs to know his drug stock levels. He could usefully have a computer interview patients so that when they arrive in his surgery, he has at least the main facts of their problems with perhaps a tentative diagnosis. He probably could use word processing for reports, form letters and the like.

There is hardly a feature of any small business or professional system which one will not find needed in the GP's surgery. Here, there is need for the storage and quick manipulation of a large database. Security is important. There are routine calculations to do, and free-ranging ones. External databases need to be accessed through Prestel or by Post Office line to specialist mainframes. There ought to be standard protocols for intercommunication with other computers so that GPs can deliver and obtain information electronically.

The BMA is proposing a £1 million trial of microcomputers in 100 practices. The trial will not only be important to the medical profession, it will also allow, for the first time, a well-organised study of the impact of microcomputing in a standard type of business. It is in the national interest that everything which can be done to improve GP service is done, so that it is not a question of giving the doctors toys.

The target population is important too. The GP is, one may presume, a reasonably well-educated person. He or she is not

necessarily a technical genius, not necessarily or even likely to be interested in machinery for its own sake. GPs are also probably not very interested in the managerial problems of running a practice. What they are interested in is looking after their patients and anything which helps them to do that better is good. So the trial will not just be about the hardware and whether it can store the bytes and retrieve them fast enough. It is also about the software designer's art: making the machines work in a sufficiently amiable way so that they do not frighten and confuse the ordinary people who will have to work with them.

Odd though it may seem to most programmers, real people in the real world do not like peering at VDUs, they hate having to type things like /46\*aQj when they do not know why, they do not want to have to wonder why the printer is being sent an extra form-feed. In fact, they do not really want to have anything to do with a microcomputer at all, if they can help it.

So, if the trial can be made to work, if it shows an acceptance of the new technology by doctors and their staffs, if it promises a real national benefit in terms of patient-care per pound spent, it will be of importance to far more than just the medical profession. It will be a solid vindication of the whole micro-computing business which is, at the moment, staggering along by fits and starts, driven by the enthusiasms of pioneers and by snagging on the resistance of unconverted lay bystanders.

How will the trial work? Happily, it is too soon to say yet, and that means there is a chance it may be structured in a way which might produce some useful results.

There are, of course, two separate elements — hardware and software. The BMA report identifies four possible options rising from a simple financial housekeeping system and an age/sex register of patients up to a full-blown system with several terminals interacting with external computers and storing plenty of information on hard discs. Since by the time the study gets under way, there will be several microcomputer systems offering 20MB on hard disc with, say, four distributed-processing workstations for about £11,000, the Scicon upper estimate of some £200,000 seems a little extravagant.

Yet, we think the problem is much more in the software. If the competition is limited in hardware to a few machines — and there is not really a vast amount of choice — it should be open to all the talents in software. It would be sensible for a list of machines, protocols and targets to be published as soon and in as general a form as possible so that the maximum of software suppliers can submit proposals. Obviously, systems which do not show some chance of doing a reasonable job will not be wished on the 100 guinea-pig practices so some vetting is necessary.

On the other hand, to restrict software entrants simply to those companies which are invited would exclude a great pool of talent and ingenuity. As the U.S. shows so well, there is nothing like a free market to stimulate performance, and while hardware provision for so large a potential market needs substantial resources, the best software can be from any head or pair of heads.

The BMA report is to be welcomed as a sensible appraisal of the new technology and a workable way of testing it. It is important not only to general practice but perhaps more so for what it implies for the whole microcomputing industry. □

## New address for *Practical Computing*

*Practical Computing* moves into new offices on November 10, 1980. From that date, our new address is: Quadrant House, The Quadrant, Sutton, Surrey, SM2 5AS. Telephone: 01-661 3500 Telex: 892084 BISPRSG.

**Our Feedback columns offer readers the opportunity of bringing their computing experience and problems to the attention of others, as well as to seek our advice or to make suggestions, which we are always happy to receive. Make sure you use Feedback—it is your chance to keep in touch.**

## Z-80 page appeal

I REALLY have no gripes with your August 1980 issue at all — although perhaps the Adventure program was not quite as well explained as it could have been. Nonetheless, a very useful program — although, I for one would like to have seen a complete small database.

The articles on machine code, contrasting 6502 and Z-80 code must also be useful to beginners — an excellent idea, especially since those two CPUs are used in all the most popular machines — who remembers the 6800 and 8080 these days?

However, what the beginner finds when he consults your various pages for specific machines/CPUs is that the only Z-80-orientated page is the Tandy one. There is a very marked 6502 bias — 6502 Special, Apple Pie, Pet Corner, etc.

What about a Z-80 Special, and, considering the 15,000 plus kits sold in this country, a Nascom1/Nascom II page. Is this too much to ask? I think not.

Just so that you have no excuse here is a very short Z-80 routine to run on a Nascom 1 or 2 to clear memory using a rather novel method.

```
OC80  E5          PUSH HL
OC81  C3 80 OC   JP   OC80H
OC84  31 80 OC   LD   SP, OC80H
OC87  21 00 00   LD   HL, 0
OC8A  C3 80 OC   JP   OC80H
```

Execute @ C84. Using the entire memory as a stack, HL is pushed repeatedly also note automatic re-set.

**J Sifton,  
Bridgewater,  
Somerset.**

## Naspen editing

MAY I POINT to an inaccuracy in the September issue of *Practical Computing*, in the Naspen review. Naspen was written by a friend of mine, and I wrote the documentation. We are both heartened to see such a fair and objective review. One always has doubts about the bias of reviewers; and this has restored my faith in reviewers in general.

However, to be specific, Nick Laurie mentions that insertion of a block text can take place only at the end of the existing text, and then the block has to be moved using the M command to the place where the insertion is required.

That is most inconvenient and slow, and in any case, not so. The L command allows insertion of text directly to the position of the cursor.

To use it, simply move the cursor to the place where an insert is required, and type L. Text may then be inserted until such time as an ESC is typed. Laurie mentions

the use of the X command to aid the re-formatting of text. It is simpler to edit out any hyphens which may have been included, then use the S command to re-format. That calls the X command automatically and then calls the "s" command. It is implied that blocks of text can only be deleted if they are to the right of the cursor by using the K command. True, but the D command will remove a block to the left of the cursor, a line at a time.

**D R Hunt,  
North Harrow,  
Middlesex.**

## Exorset opinions

WE READ with interest your review of the Exorset 30 in the September issue, and agree with most of its conclusions. We bought an Exorset early this year and delivered it to a customer who wanted a one-off industrial-control system; we found its hardware an excellent vehicle for our software.

The quality control on our first machine. The clearly-visible offending PROM, not properly inserted in its socket, caused the XDOS system disc to be destroyed on first powering-up the machine. The clearly -visible offending pin was less than 2in. from a sticker saying: "final inspection OK". Four days later, the very impressive-looking PSU destroyed itself.

The machine was very promptly replaced and produced no more trouble. A design problem was that powering-up the machine with discs inserted sometimes loaded the heads, destroying disc format.

We found, like your reviewer, that the software was not up to standard. The assembler, editor and Basic cannot handle disc-to-disc operations, and our programs had to be arbitrarily and clumsily subdivided to make them fit. That was a real problem.

Similarly limiting was the fact that assembler listings could not be directed to the RS232 port, but only to a Centronics parallel interface. Among several bugs we discovered was the rather fundamental one of Basic sometimes making mistakes with the unary-minus operator.

We did, however, eventually deliver a system which used compiled Basic, 4K of assembler, XDOS disc I/O and high-resolution graphics simultaneously.

It seems that the software has been put together piecemeal from extant modules, producing unnecessary limitations. It is definitely not up to the quality of the system hardware design. However, having

learned to pick our way round its problems, we found the machine highly versatile and usable.

We look forward to similarly accurate reviews from your magazine in the future.

**E J Williams,  
D A Fielder,  
Milton Keynes,  
Buckinghamshire.**

## Acorn Atom group

I AM writing to announce the existence of the Acorn Atom user group. It is intended to give Atom users a forum in which to air their views, and to provide an opportunity to exchange software and hardware tips and programs.

Membership is open to all, private, educational and commercial users. Membership costs £4 p.a., and includes access to the library and free newsletter.

**R G Meredith,  
Newton Ferrers,  
Devon.**

## Two-speed enquiry

I AM enquiring about the two-speed modification you published for the TRS-80, Model 1, Level II in the September issue. Do you know if it is possible to install something similar, but allowing the speed to be changed with a program in memory?

I would like to be able to load programs at the old speed, and then switch to the faster speed before RUNNING or re-saving the program. I have a reasonably large number of programs, both in Basic and System format and would like to be able to run them at the faster speed without having to re-type them and Csave them again.

**R Huntley,  
Gosport,  
Hampshire.**

## Upgrading Pet

HAVING been a reader of your excellent magazine since the first edition, I would like to say that I think it goes from strength to strength, and is now much improved.

I have, however, a problem which someone might be able to solve. I have a 16K Pet, with discs and printer which I want to upgrade to 32K. However, I cannot discover what changes are needed in the address decoding to enable me to unplug the 4108 RAM chips, and replace them with 4116 chips.

I understand that all that is required is to change the links on the link chip to the back on the right, but I cannot work out

*(continued on page 44)*

**"IT IS IMPOSSIBLE TO TRANSMIT THE VOICE OVER WIRES AND WOULD BE OF NO PRACTICAL VALUE."**

-NEWSPAPER EDITOR ON TELEPHONES, 1865.

**"I WISH NO-ONE TO KNOW THAT I AM USING THIS STRANGE DEVICE."**

-MARK TWAIN ON HIS FIRST TYPEWRITER.

# Now what was that you were saying about getting a small computer?

Without any doubt, the computer will soon be as indispensable as all the other office equipment you now take for granted.

And to this end, IBM have developed a range of small computers to help release the staff of smaller businesses for the more creative tasks for which they were employed in the first place.

They start at around £8,500—excluding VAT, and you'll be pleased to learn that you won't need to employ specialist staff to benefit from them.

We're able to supply just as much computer as a small business might need, starting with the IBM 5120.

Rather than dismiss these computers as 'new fangled' or unnecessary, may we suggest you fill in the coupon and send it off to us.

In the meantime, to help make your decision easier, try getting by without the typewriter or the telephone.

## **A small computer can make a big difference.**

I would like more information about your small computers.

NAME

COMPANY

POSITION

ADDRESS

POST CODE

TEL.

PC11

To: General Systems Sales Information,  
IBM United Kingdom Limited,  
PO. Box 32, Alencon Link,  
Basingstoke, Hampshire RG21 1EJ.  
Tel: Basingstoke (0256) 56144.

• Circle No. 156

(continued from page 42)

what the changes should be. If anyone can help, I am sure there are other readers who would be interested to know about it.

I admit I was wrong when I bought the Pet. I thought that when I exchanged my 8K for 16K plenty of space would be available for anything I would write; that is not so. Let me advise anyone who is contemplating a 16K to buy a 32K — you never know what you may need in the future.

**Peter Dolphin,  
Petersfield,  
Hampshire.**

• According to Nick Hampshire, you need to set the links thus: "C" for closed, "O" for open:

H Closed	A Open
I Closed	B Open
J Closed	C Closed
K Closed	D Closed
L Open	E Open
M Open	F Closed
N Open	
P Closed	
R Open	
S Closed	

## Basic support

IT WAS with pleasure that I read your editorial in the June issue. Over the past year there appears to have been a growing attack on Basic.

Micros are for the small user — the less technical — and, as you state, most programs written for micros are far shorter than the number of lines limit imposed by the computer. Even a 2,000-line program is a long one and are nearly always written by one person.

We should divorce our thinking away from mainframe and remember that the reasons microcomputers caught on were that they were available comparatively cheaply and, more important, that the computing language Basic was understood easily and usable even by the inexperienced.

In short, Basic and its improvements suit the majority, who are happy with it and find that it does all that they want it to do; it is the majority who have made microcomputing take off. All strength to your support for Basic.

**R F Cox,  
Leicester.**

## Software availability

YOUR VERY readable editorial in the September edition draws attention to the disappointing state of software availability for micros so far. I agree but am not sure that it is as surprising as you infer. I believe the missing link may be the production of general-purpose software modules, which would give us, in effect, a higher-level language.

It is hard for the novice to see what they might consist of, but it does seem to me

that one reason why software is not forthcoming for a wider range of applications is simply because the people who have the know-how on the application side find, when they try their hand at producing programs, that they spend a good deal of time re-inventing the wheel — and probably producing square ones at that.

Although programming is basically easy, my limited experience has been that one spends a good deal of time learning tricks of the trade which could, in fact, be incorporated into more sophisticated software.

I suppose the fact is that the hardware is still not quite cheap enough to provide the programming tools I am envisaging which would, if truly versatile, necessarily be inefficient. Until that state is reached, I would suggest that we probably will not find much good-quality software covering a broad spectrum of activities.

Meanwhile, perhaps the mainframe experts should direct some energy towards the production of some singing and dancing multi-purpose modules for when the 32K ROM costs only a pound or two — including programmers' royalties, of course.

**M H Hudson,  
Goudhurst,  
Kent.**

## Apple user's advice

I HOPE you will forgive the presumption of an Apple user writing about a Pet column, Pet Corner, September, but I feel that the letter from Robert Acraman may give people problems because I suspect that the addresses at the start of lines in Pet Basic would be used when a Goto or Gosub is encountered. If that is the case, pointing a line at itself will give a Hang at the first Goto.

Why are people so psychotic about having their programs listed? What if Goya, Cezanne and Picasso had felt the same and made their works unviewable? Perhaps it is only the less competent programmer who wants to hide his dim light under a bushel.

Thanks, anyway, for an interesting column, although you must find it very difficult to find anything interesting to say about the Pet.

A quick tip to finish off which should work for the Pet. Less organised programmers than you or I possibly find themselves knee-deep in Gosubs when the user presses the key which indicates that he wants to go back to the main screen/menu. Working out how many POPs to do or putting in code at each return point can be time-consuming. An alternative is to handle it with ONERR such:

```
10 ONERR GOTO 1000: REM LINE
   NUMBER OF MAIN SCREEN
20 GOTO 1000: JUMP AROUND
   SUBROUTINES
100 POP: GOTO 100
   Any time you want to return to the
```

menu, GOTO 100 will put you in a loop which will clear the GOSUB stack and end with an error which will send you off to line 100. That should work in most Basics with POP and ONERR.

**Bill Skipton,  
Tamworth,  
Staffordshire.**

## Cassette levy protest

I HAVE read in the National Press, *Guardian*, August 21, that a £1 levy is to be imposed, by the Government, on blank cassette tapes for the benefit of the British Phonographic Industry to offset the costs of record piracy.

Perhaps those who agree with me that this more than constitutes an intolerable imposition on users such as computer hobbyists will write to their MPs to that effect.

**J R Handford,  
Gosport,  
Hampshire.**

## ZX-80 heatsink

I WAS most interested in the Heated Discussion in your August ZX-80 page. My son and I had a very similar discussion with our ZX-80. We built our ZX-80 from a Sinclair kit and from switch-on, it operated perfectly.

After three days of intensive use, it began, however, to switch off for no apparent reason. At first, we decided a possible reason was overheating and so we checked that the operating load current was within specification and steady as a rock regardless of operating mode. We found that two small pieces of Meccano enabled the effective CSM of heatsink to be increased within the confines of the cover. The fault persisted.

A systematic examination of all soldered joints was made to check the supply voltage from the power unit. That voltage on load was out of specification, hence, we now assumed that the regulator was being asked to control excessive power and the heatsink was being overworked.

We did not have a suitable supply dropper to hand, so the examination of the soldered joints continued. Two or three joints were re-soldered. Since the supply dropper was wired in live, the ZX-80 has given no trouble in any mode.

Our fault may have been a soldered joint or overheating or both. The dropper was housed in a tobacco tin, and it is a comfort to feel a relatively cool ZX-80 and a hot tobacco tin.

The only reason I bought a ready-made power supply was to have at least one set-up without a tobacco tin being involved at any stage.

My only disappointment is the lack of capability in the mathematics function, otherwise I think the ZX-80 is a very good buy.

**G Winterburn,  
Lytham,  
Lancashire. ☐**

NEWBURY NEWBURY NEWBURY

# Smart Micro-based Visual Display Terminals

24 lines of 80 characters per line. 96 ISO/ASCII character set. Dual interface - CCITT V24 and 20/60 mA current loop. Selectable half or full duplex. Green phosphor non glare display.

## 7000

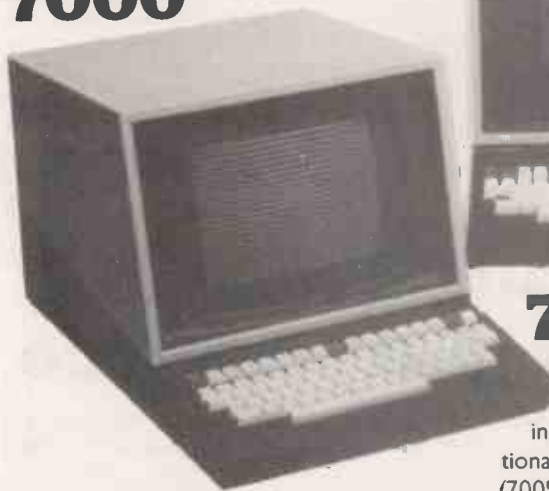

Hard copy print out  
Numeric pad  
Video output for external monitors

## 7002



## 7007/9

Full key-board editing features. Additional 6 pages of memory (7009). Block transmission by line or page.

## Matrix Printer



125 cps printing speed.  
CCITT V24 (RS232) interface  
80-132 characters per line

from **£460\***

Prices from **£495\***

### Emulations:

APL, DEC VT52, ICL 7181 Honeywell  
VIP 7006 & 7250

\*Prices inclusive of delivery in UK and cables ready to plug in.

## NEWBURY LABORATORIES LTD

Head Office & Sales:  
King Street, Odiham, Hampshire RG25 1NN  
Tel: 025-671 2910 Telex: 858815

### Sales and Service:

North East Tel: York (0904) 412043  
North West Tel: Stockport 061-491 0134  
Midlands Tel: Birmingham 021-707 7170  
East Anglia Tel: 0223 64862  
Scotland Tel: Edinburgh 031-554 0051

• Circle No. 157

# Sinclair reveals plans for ZX-80 expansion

CLIVE SINCLAIR, designer and entrepreneur behind the popular ZX-80 micro-computer, has released details of some of his future plans for the ZX-80. Last month, Print-out reported that he had announced a new 8K ROM Basic and a new 16K memory expansion for the ZX-80.

The latest plans include an RS232 port with a translation ROM which is already in an advanced stage of design. It will be released to the market as soon as possible and will enable users to attach printers to their ZX-80s.

Other plans include a teletext adaptor which could be announced towards the middle of next year. It is understood that an independent television company, in the U.K., is

interested in broadcasting software for the ZX-80 on standard teletext channels and Clive Sinclair.



intends to make money by selling advertising space on the same pages.

The adaptor will also be compatible with Prestel, allowing users to write programs which could select

information automatically from the Prestel computer.

Sinclair has also been talking about his plans for the U.S. market in which he hopes the ZX-80 will become the top-selling microcomputer by the beginning of 1981. The U.S. software house, Image Products, has already been appointed as the main worldwide agent for ZX-80 software and the first manual of ZX-80 software will be published shortly.

It will include details of programming standards should any users like to submit their own work. A copy of the specifications should be available from Science of Cambridge, 6 Kings Parade, Cambridge (0223) 311488/312919.

## Music with TRS-80

ALL THE interesting add-ons for the Tandy still seem to be from the U.S. — the latest is Orchestra-80, a TRS-80 music synthesis system. It requires a 16K Level II TRS-80, some software and a PC board which plugs into the expansion connector of the TRS-80 keyboard.

The software is a five-part machine language program; a digital synthesiser which produces four simultaneous voices in a six-octave range; a music language compiler, which allows users to enter their favourite music in any key or time signature; a full-function text editor with blinking cursor; and a file manager, which stores and retrieves named program files on tape or disc. Details from Software Affair Ltd, 473 Sapena Court, Santa Clara, California. A demonstration of the music is available on 0101-408 727 8194.

## Home study of Z-8000

SEMICONDUCTOR company and manufacturer of the Z-8000 16-bit microprocessor, Zilog, has introduced a five-lesson, home-study course on Z-8000 architecture for systems engineers.

The course teaches the details of the Z-8000s 16-bit architecture, techniques of memory management, methods of interfacing memory and peripherals, proper handling of interrupts and traps and use of the Z-8000s instruction set.

Each lesson includes a test consisting of 10 questions which is individually graded by Zilog prior to the next lesson. The first lesson introduces the Z-8000 architecture, starting with a description of the function of each signal pin on the Z-80001 and Z-80002 processors. The second lesson concentrates on memory and peripheral interfacing; lesson three discusses interrupts and traps. The final two lessons study memory and peripheral management and an overview of the instruction set. The course costs £19.50 and details are available from Zilog on Maidenhead (0628) 36131.

# Hard-disc controller eases back-up and maintenance

THE BEST ideas are always blindingly obvious — when they have been pointed out. We have been growing very excited about Winchester discs, wishing they would arrive, wishing they would cost less, trying not to think about the problem of back-up — without ever asking ourselves what the mainframe world has been

doing about backing storage.

The simple answer is that they use an absolutely standard hard-disc system which has been available for years, is easy to repair, has five or 10MB on-line and five or 10MB in a removable pack for back-up. Only now has someone had the wit to adapt it for micros.

Various versions of discs to

the IBM-5540 standard are made by Ampex, CDC, IBM, Western Dynex. There are nearly 250,000 in service and they do not need air-conditioning. Access time averages 35 milliseconds — about six times faster than 8in. floppies — and data leaves the disc at 2.5MB a second.

Newtons Laboratories of Wandsworth has produced a hard-disc controller for the S-100 bus.

Its controller board makes the hard disc run CP/M 2.2 so you can add them to your existing floppies. Up to four hard discs can be daisy-chained together, and Newtons promises a 20MB version in a few months.

The advantages over the Winchester system are back-up with the removable pack — most important — and easier maintenance.

The disadvantage is of considerably larger size — about six cubic ft. as against the legendary shoebox; but for the same price £3,500. Telephone 01-874 6511.

The hard-disc controller for the S-100 bus.



## Director chosen for State scheme to develop schools computing

THE director of the £9 million Government-funded national development programme in microelectronics in schools and colleges has finally been announced as Richard Fothergill, currently head of Petras at Newcastle Polytechnic.

Fothergill established Petras, the educational development unit at Newcastle Polytechnic, which has become a centre of advice about educational technology in the north of England. In the past two years, he has prepared a number of learning materials

on microelectronic subjects.

The small staff of the Directorate will, under the arrangements with the Department of Education and Science for the administration of the program, formally be employees of the Council for Educational Technology. Although the Director will be based in Newcastle, his office will have a direct telecommunications link with

the Council for Educational Technology offices in London.

In October Printout, we reported the names of the Government-appointed Advisory Committee — the scheme which has already been criticised by the National Union of Teachers for including no teachers from the State sector on either the main committee or the group of external advisors. □

## Delay for Pet disc drive

IN THE September issue we carried a story about the new ACT 2MB Computhink disc drive for the Pet. The equipment is immediately available for the 32K Pet, but there is some difficulty about adapting it for the new 80-column Pet. ACT estimates delivery at six to eight weeks.

The problem seems to be that in the big-screen Pet, the ROM area where the disc controller used to sit is used for another purpose. □

## First wave of business programs launched for Pet 8000 series

IN THE four months since the formal U.K. launch of the new Pet 8000 series, Commodore has been busy trying to

encourage its approved dealers to produce some serious and suitable business software.

To win the mark of

approval, dealers have had to follow the specifications and standards laid down by Commodore. The first series of business programs has now been launched through the Commodore-approved product dealers' network including packages such as payroll, sales, purchase and nominal ledgers, word-processing and communicators.

The Essex-based Commodore dealer, Dataview, has been one of the first to unveil the latest version of Wordcraft, Wordcraft 80, for the 8000 series. It is a development of the established Wordcraft program adapted for use on the 8000 series and making full use of the improved screen facilities.

It will be sold for £375. A typical complete system, with an 80-column screen Pet, twin floppy disc drives and a good quality daisywheel printer will cost about £4,200. □

The Wordcraft package on the Pet 8000.



## Anadex solves printer error

ANADEX has announced that some earlier models of their DP-9500 and DP-9501 printers may exhibit an operating error when used in a serial mode at high baud rates, resulting in loss of characters or incorrect horizontal tabulations.

A change in the printer software to eliminate the error has now been incorporated and is effective from serial number D006670 for the DP-9500 and serial number D00311 for the DP-9501. □

## Industrial measurements from I/O subsystem which works with all types of micro

A MICROPROCESSOR-controlled input/output subsystem for use with all types of micro-computers has been introduced by M C Computers Ltd, of Newbury. Essentially a simple connection interface, providing either local or remote operation, PIP — Plant Interface Peripheral — will make a variety of industrial measurements and transmit them on a standard communications link.

Designed around a conventional 19 in. Industrial Euro-rack, PIP uses front-loading, plug-in circuit cards. A number of plug-in options such as analogue output, digital input/output, dual counter card and battery back-up and memory cards are available.

PIP will accept up to 128

single-ended or 64 differential multi-plexed inputs and can both analogue and digital outputs.

A built-in, high-speed

analogue-to-digital converter gives 12-bit resolutions and 11 binary ranges. M C Computers can be found on Newbury (0635) 44967. □

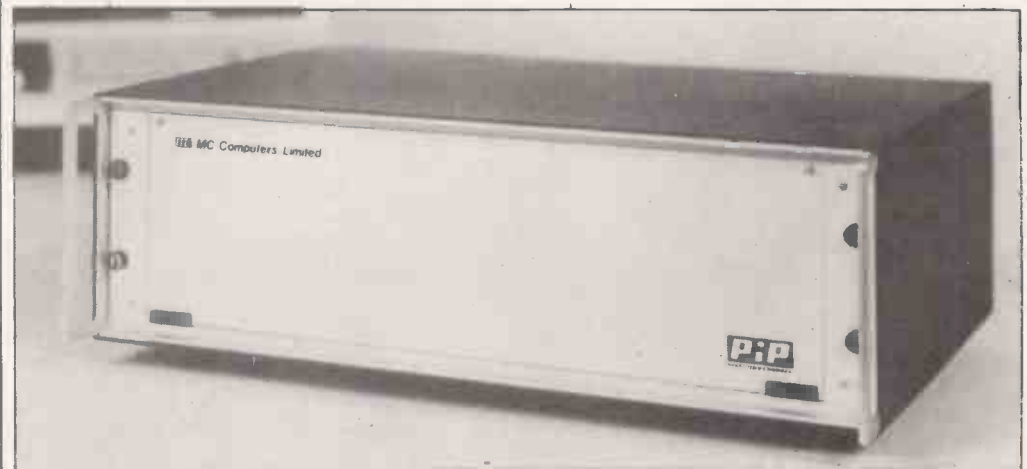

# BUTEL-ATHENA

## The Ideal Small Business System

The ATHENA is just what your growing business needs. The high performance ATHENA can deal with all your accounting, stock control, word processing and other requirements. It is simple to use, has only a single power lead and can be expanded with multiple terminals and more storage.

Prices start at £5694. Write or call for details.



ATHENA Dealerships Available.

**BUTEL**  
Technology for business

Butel-Comco Limited  
50 Oxford Street,  
Southampton,  
England SO1 1DL  
Telephone 0703 39890  
Telex 47523



## New share market may help micro firms raise capital

THE STOCK Exchange looks set to create an entirely new market in shares — an Unlisted Securities' Market (USM) — specifically for young high technology companies unable or unwilling to meet the Stock Exchange stringent membership requirements. The USM could provide an easy way for many of the emerging U.K. microcomputer companies to finance their rapid growth without selling all of their shares.

Companies which enter the new market will have to offer only 10 percent of their equity to the public as opposed to 25 percent on the main market.

Companies applying for the market will only have to provide three-year records of their trading although even these requirements will be lifted if a company wants to turn to the market to finance the production of new products. The market has been approved and should start work by the end of the month.

The concept of limited

## U.K. machines for Compec

TWO NEW U.K.-designed and built microcomputers are about to be introduced by Haywood Electronics Associates, of Northwood Middlesex, just in time to be shown at the *Practical Computing* sponsored Compec Exhibition in Olympia.

The smaller of the two is the 3000, a single-board microcomputer with many of the features now almost standard requirements. Based on the Z-80A running at 4MHz, RAM is expandable from 32K to 64K.

The Haywood 7000 is another 'standard' microcomputer with 8in. discs drives to provide more than 2.5Mbytes of storage on two floppy discs. The 7000 is a complete system with a VDU, keyboard and printers matched together with software and an integrated business systems. Details are available from Haywood Electronics Associates Ltd, Northwood 28301. □

liability companies was invented in the U.K. at the start of the industrial revolution as a way of allowing people to invest in new ventures, such as canals and railways, without risking their entire fortunes should the venture collapse.

Over the years, the idea has become increasingly embroiled in new regulations to try and safeguard even the limited investment of the investor so that now only well-established and safe companies are willing to comply with the strict rules and conditions about trading and reporting practices which enables them to join the select club the Stock Exchange now represents.

As a medium for raising capital for new, risky but potentially money-spinning

and job-creating ventures, the Stock Exchange has been in decline for many years.

One way in which it has been possible to break into the Stock Exchange without meeting the traditional requirements has been through the Market Rule 163(2), designed originally for special categories but which has been used increasingly as a backdoor for young high-risk companies.

The Stock Exchange has been worried about the number of companies entering the market through this rule, that they could not be regulated effectively and that scandals or collapses in the sector could damage the reputation of the rest of the market. □

## Increased computer thefts lead to more security devices

REPORTS of computers being stolen are becoming increasingly frequent. We have heard stories of microcomputers being stolen from exhibitions, from shop displays and from people's homes. The latest incident occurred when Jill Hebditch, a director of the software company Microtrend, parked her car on the rear access road of the Cunard International Hotel in west London on September 3.

She returned to find that a Commodore disc drive and a Hazeltine VDU had been stolen.

The Commodore 3040 Dual The NASA anti-theft device.

Diskette Drive has a serial number 608041; the Hazeltine 1520 VDU a serial number 300596-022. If you encounter either of the items, telephone Detective Sergeant Ball of Hammersmith CID on 01-741 6071.

A product which would help prevent the theft of such easily transportable items as microcomputers and their peripherals has been introduced by NASA — Noise and Security Appliances. The company is starting to market an anti-snatch alarm which can be fitted out of general view inside the back of a machine.

## Software at W H Smith

W H SMITH, the large newspaper and magazine distribution chain, is toying with the idea of selling software games on cassette through its high street branches. An experimental display, entitled "The Computer Know-how" has been built in the Brent Cross branch in north London where "there is a young customer profile" according to John Rowland, the W H Smith marketing development manager.

"We do not think there are enough personal computers in the market to justify selling software through all our stores but in the longer term this is obviously a market we shall be in", says John Rowland.

The programs on sale have been supplied by ACT and the new software company Microtrend. □

The basic model is wired into the mains with the power supply for the system. While still plugged-in, the anti-snatch will not operate but once the connection is broken and the machine moved even the slightest amount, a trembler switch triggers an alarm.

The alarm has a starting price of £40. Details from NASA on Uxbridge 59575 □

## New ROM for Level II

TANDY HAS started to introduce a TRS-80 Level II microcomputer with a new ROM, possibly creating for Tandy owners some of the problems which Pet owners already face with the confusion between the new and old-ROM Pets.

The majority of Tandy programs should run normally although it seems somewhat unfortunate that the very few which do not are some of Tandy's own games. Other features of the new ROM are the CLOAD and CLOAD? can only be performed through the number-one tape drive and DOS users can now specify a file name. □



# Micromouse

THE long-awaited Micromouse contest, part of the Euromicro '80 conference held at Imperial College, has produced a worthy champion. The winner of the first and most important of the three contests — fastest time through the maze — was Sterling Mouse, built by Nick Smith and P T Crow from Ruislip, Middlesex, one a systems analyst with British Gas and the other a sparks.

They both claim to have started knowing nothing about the mechanics of mouse-building — Smith had to teach himself how a transistor worked to build the motor control circuits.

Of the eight competitors, Sterling Mouse was the only one to find the centre. Smith and Crow collected the \$1,000 first prize from Euromicro.

Curiously, it turned out that the real difficulty in maze running is not the writing of a

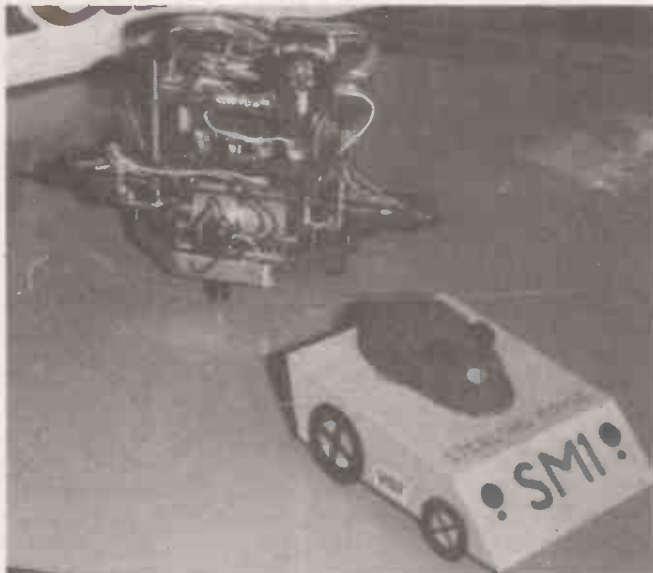

Sterling Mouse, the fastest mouse through the maze.

made of Leggo, held its whole program in 200 bytes.

Almost all the competitors agreed that what at first seemed the major obstacle posed no real problems. The difficulty was navigation in the maze. In planning, it was too easy to assume that the mouse moved from the centre of one maze cell to the next. In practice, it was far less simple.

Mice often became jammed and disorientated in the opening between one cell and the other, or wedged in a corner, making ineffective rightangle turns to left and right.

Navigation systems based on

summing left and right wheel rotations tended to fail because of wheel slip on the taped-over joints in the baseboard. The simple matter of turning left or right into a new maze corridor involved detecting the opening, stopping the motors, allowing for forward motion between issuing the stop command, the mouse stopping, measuring the mouse's position in relation to the opening and adjusting any error. It turned out to be a far from trivial task.

Technically, the most interesting machine was the Swiss Lami. This device was square in plan, with a large wheel in the middle of each

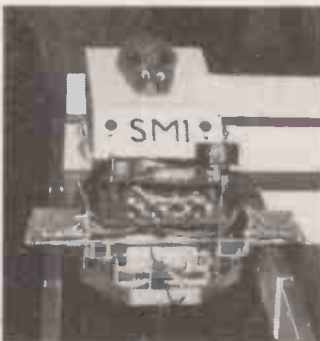

The champion in action.

computer program to explore the maze. Sterling did that in just 29 machine-code instructions; Brainy Bricks, the mouse

Brainy Bricks, the mouse made of Leggo, negotiates a difficult corner of the maze.



side. To allow it to move at all, each wheel had 24 tiny wheels mounted round its rim with their axes tangential to it. A big wheel driving used the small wheels like coarse tread tires; a large wheel idling ran forward on the small wheels.

A mouse either needed a very clever sensor system designed for the maze, or a very elaborate one that would position it anywhere. The Plessey unofficial entry, Fred, positioned itself by blasting out infra-red pulses front and rear.

The designers said they would, next year, rotate the pattern by 45° so that two sensors would detect a side wall instead of just one. Given an all round set of detectors like that, a mouse might have a chance of disengaging itself from corners.

It was interesting that the winning entry had the simplest



Fred delighted the crowd with his singing and dancing in the free-style event.

sensor system. It had one bendy wire at the front connected to a microswitch to detect a barrier in front, and an ingenious wing on each side which ran along the top of the maze walls.

If the mouse moved too close to the wall, the wing rode up on an extra bump in its arm-pit. If it met an opening, the wing on that side dropped. The problem of timing the stop was solved by giving the wings upward-angled trailing edges so that the amount of drop signalled the distance forward from the start of the opening.

Although Sterling Mouse had no real competition, it moved intelligently and fast and would no doubt give the Americans some aggravation. □

We are now entering our fourth financial year of dealing solely in the personal computer market — in fact, we started it! Over this period, Personal Computers Limited have formed a group of graduate specialists who will help you in the fields of word processing, financial planning, statistics, economic modelling, forecasting, accounting systems, foreign exchange, banking and oil exploration. We also do rather well with computer graphics and highly recommend the graphics tablets and our plotter for Apple.

We can also offer two excellent items of software — **Format 40** and **Visicalc** — at a combined price of **ONLY £189**, and the **Super Sound Generator** for only **£90!** (excl. V.A.T.)



**8" Disk Drive (above left)**

Our 8" disks are still as popular as ever — 2 drives give you 1.2MB with all the reliable security of Shugart Technology. Easily interfaced to Apple, uses the same D.O.S.

**A.I.O. Serial and Parallel Card (above centre)**

Three hand-shake lines (R.T.S., C.T.S. and D.C.D.). Firmware for serial interfaces on-board, software for parallel printer available, 2 bi-directional 8 bit parallel ports, plus 4 additional interrupt and hand-shaking lines.

**Light Pen (above right)**

A much sought after product which we introduced to the U.K.

**80 Character Card (below left)**

... opens up the real commercial world for all Apple owners.

**Paper Tiger (Below centre)**

132 character line, plus graphics, 8 character sizes, ordinary paper, multiple copy, upper and lower case 96 character, parallel/serial, form control.

**Centronics 730 (Below right)**

A substantial, robust printer from a major manufacturer. 3 way paper handling system, 100 character per second. Special low-cost including interface. 96 characters.



**Items pictured**

**Sharp MZ — 80K**

A new generation of personal computer, self contained, versatile and starting at only **£570** (excl. VAT). Explore the Zilog Z80 now the easy way. Disks and printer available shortly.

**Numeric Keypad**

... with 8 function keys is a must in all financial applications.

**TCM 100 & TCM 200**

... both now have graphics as well as their own power supply, essential with this type of printer.

**Qume Sprint 5**

The quality word processing printer. Clean, clear executive reports the way you want them. Can print up to 5760 points per square inch — or even print in 2 colours.

# This is what we do..

## and we do it rather well!



**Personal Computers Limited**  
194-200 Bishopsgate, London EC2M 4NR. Tel. 01 626 8121

For further information, please complete this coupon and post to:  
Personal Computers Limited, 194-200 Bishopsgate, London EC2M 4NR.

NAME \_\_\_\_\_  
ADDRESS \_\_\_\_\_

**\* Now here, details for**  
**APPLE III**

PC11

# SUPERBRAIN™

FROM **SUN** THE GROUP WITH A WEALTH  
OF HARDWARE & SOFTWARE EXPERIENCE  
IN THE COMPUTER INDUSTRY.



## NOW WITH

- TWO QUAD-DENSITY FLOPPIES (788K) OR TWO DOUBLE-DENSITY (320K)
- TWIN Z-80A MICROPROCESSORS
- 64K RAM
- CP/M OPERATING SYSTEM
- M BASIC FORTRAN PASCAL COBOL
- UP TO 90 MBYTE HARD DISK OPTION
- WORDSTAR WITH MAILING CAPABILITY
- INTEGRATED BUSINESS PACKAGES

FOR FURTHER INFORMATION CONTACT YOUR NEAREST DEALER

COMPUTER SALES & SOFTWARE CENTRE LTD., 190-192 CRANBROOK RD., ILFORD, ESSEX.  
01-554 3344

DEACON HOARE & CO. LTD., 27 REGENT ST., CLIFTON, BRISTOL. BS8 4HR. (0272) 312374

HARTLEY COMPUTING; 16 PARK RD, COVENTRY, CV1 2LD. (0203) 27851

JAGOR TECHNICAL SYSTEMS LTD., 81 ATHERLEY RD., SOUTHAMPTON, SO1 5DT. (0703) 20579

KARADAWN LTD., 2 FORREST WAY, GATEWARTH INDUSTRIAL ESTATE, GREAT SANKEY,  
WARRINGTON. (0925) 572668

MERCATOR MANAGEMENT CONSULTANTS LTD., 6 VYVYAN TERRACE, CLIFTON, BRISTOL,  
BS8 4HR. (0272) 33636

MICRO AUTOMATION COMPUTING LTD., 207 PUTNEY BRIDGE RD., PUTNEY, LONDON SW15 2NY  
01-874 2535

PENNY RENTALS, 15 MAIN AVENUE; PETERSON-SUPER-ELY, SOUTH GLAMORGAN, CF5 6LQ.  
(0446) 760681

ROGER SALISBURY SMITH, COMMERCIAL SERVICES, MOONRAKERS, WHEATSHEAF ENCLOSURE,  
LIPHOOK, HANTS. GU30 7EJ. (0428) 722563

SYSTEMATIKA LTD., 36 MONTPELIER GROVE, LONDON, NW5. 01-586 4585

TURNKEY COMPUTER TECHNOLOGY LTD., 23 CLADERGLEN RD., ST. LEONARDS; EAST  
KILBRIDE. (03552) 39466

OR

## SUN COMPUTING SERVICES LTD

138 CHALMERS WAY, NORTH FELTHAM TRADING ESTATE,  
FELTHAM MIDDX. TEL: 01-751 5044  
TELEX: 8954428 SUNCOMG

Unique in concept—the home computer that grows as you do!

# The Acorn Atom

# £120

plus VAT and p&p

Special features include

- \* FULL SIZED KEYBOARD
- \* ASSEMBLER AND BASIC
- \* TOP QUALITY MOULDED CASE
- \* HIGH RESOLUTION COLOUR GRAPHICS\*

\* optional



Also available ready-built  
**£150**  
plus VAT and p&p

● The picture shows mixed graphics and characters in three colours

The Acorn Atom is a definitive personal computer. Simple to build, simple to operate. A powerful, full facility computer with all the features you would expect. Just connect the assembled computer to any domestic TV and power source and you are ready to begin. (Power requirement: 8V at 800mA). There is an ATOM power unit available – see the coupon below:

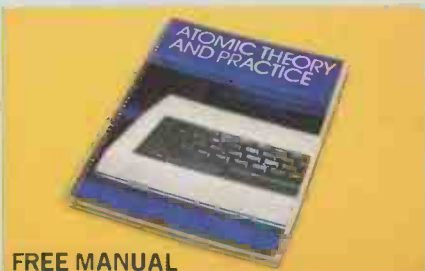

### FREE MANUAL

Free with every ATOM, kit or built, is a computer manual. The first section explains and teaches you BASIC, the language that most personal computers and the ATOM operate in. The instructions are simple and learning quickly becomes a pleasure. You'll soon be writing your own programs. The second section is a reference

manual giving a full description of the ATOM's facilities and how to use them. Both sections are fully illustrated with example programs.

#### The standard ATOM includes:

- HARDWARE**
- Full-sized QWERTY keyboard
  - 6502 Microprocessor
  - Rugged injection-moulded case
  - 2K RAM
  - 8K HYPER-ROM
  - 23 integrated circuits and sockets
  - Audio cassette interface
  - UHF TV output
  - Full assembly instructions
- SOFTWARE**
- 32-bit arithmetic ( $\pm 2,000,000,000$ )
  - High speed execution
  - 43 standard/extended BASIC commands
  - Variable length strings (up to 256 characters)
  - String manipulation functions
  - 27 x 32 bit integer variables
  - 27 additional arrays
  - Random number function
  - PUT and GET byte
  - WAIT command for timing
  - DO-UNTIL construction
  - Logical operators (AND, OR, EX-OR)
  - Link to machine – code routines
  - PLOT commands, DRAW and MOVE

#### The ATOM modular concept

The ATOM has been designed to grow with you. As you build confidence and knowledge you can add more components. For instance the next stage might be to increase the ROM and RAM on the basic ATOM from 8K + 2K to 12K + 12K respectively. This will give you a direct printer drive, floating point mathematics, scientific and trigonometric functions, high resolution graphics.

From there you can expand indefinitely. Acorn have produced an enormous range of compatible PCB's which can be added to your original computer. For instance:

- A module to give red, green and blue colour signals
- Teletext VDU card (for Prestel and Ceefax information)
- An in-board connector for a communications loop interface – any number of ATOMS may be linked to each other – or to a master system with mass storage/ hard copy facility
- Floppy disk controller card.

For details of these and other additions write to the address below.



**ACORN COMPUTER** 4a Market Hill, CAMBRIDGE CB2 3NJ

Your ACORN ATOM may qualify as a business expense. To order complete the coupon below and post to Acorn Computer for delivery within 28 days. Return as received within 14 days for full money refund if not completely satisfied. All components are guaranteed with full service/repair facility available.

Please send me the following items:

Quantity	Item	Item price inc. VAT+p&p	TOTALS
	ATOM KIT – 8K ROM + 2K RAM (MIN)	@ £140.00	
	ATOM ASSEMBLED – 8K ROM + 2K RAM (MIN)	@ £174.50	
	ATOM KIT – 12K ROM + 12K RAM (MAX)	@ £255.00	
	ATOM ASSEMBLED – 12K ROM + 12K RAM (MAX)	@ £289.50	
	1K RAM SETS	@ £11.22	
	4K FLOATING POINT ROM (inc in 12K Version)	@ £23.30	
	PRINTER DRIVE	@ £10.35	
	(inc in 12K version) 6522 VIA	@ £3.17	
	LS244 Buffer	@ £10.20	
	MAINS POWER SUPPLY (1.3 amps)		
	<b>TOTAL</b>		

To: Acorn Computer Ltd., 4a Market Hill, CAMBRIDGE CB2 3NJ

I enclose cheque/postal order for £ \_\_\_\_\_

Please debit my Access/Barclaycard No. \_\_\_\_\_

Signature \_\_\_\_\_

Name (Please print) \_\_\_\_\_

Address \_\_\_\_\_

Telephone No. \_\_\_\_\_

Registered No: 1403810. VAT No: 215 400 220



• Circle No. 161

RAIR BLACK BOX  
MICROCOMPUTER

POWER

LOAD

RESET

RAIR BLACK BOX  
MICROCOMPUTER

*Discover the secrets of  
the RAIR Black Box*

# Compec Preview

In this preview of the Compec Exhibition, held in the Grand Hall of London's Olympia from November 4-6, *Practical Computing* looks at some of the products which are on show in the U.K. for the first time.

SPONSORED by *Practical Computing*, and some of its sister publications, Compec is already Britain's biggest and most successful computer exhibition. Visitors and exhibitors attend from all over the world to see and to launch new products on to the U.K. and European computer markets.

This year, more than 350 stands have already been booked by exhibitors ranging from the mainframe companies, mini- and microcomputer manufacturers, dealers, suppliers, service companies and peripherals and software companies.

Compec represents a rare opportunity to find so much of the industry under one roof, to hear the very latest plans and announcements, to talk to the Trade and to find the solution to your computing problem whether it lies in industry, business, education or your home.

## Well-known companies

Almost all the well-known companies which *Practical Computing* readers hear about each month are well represented: the list includes Commodore, Sharp, Microsense for the Apple, Nascom — under a new owner, Acorn with the Atom, the printer manufacturers, software suppliers and a selection of the smaller companies in the market.

On the home front, one of the key attractions could prove to be Sharp, on stand 2155, which is using the show to announce some interesting enhancements to the MZ-80K microcomputer and

The General Automation Boss I is launched at Compec.



launching a brand-new machine for the small business market.

The enhancements to the MZ-80K include the first demonstration of the system running CP/M, developed for Sharp by Crystal Electronics of Torquay which will perform the necessary modifications. It broadens significantly the range of software MZ-80 owners can run.

Sharp is also introducing, or at least demonstrating, the MZ-80K colour



The Elbit Micropact microcomputer.

monitor for the first time. It has a 14in. screen and four modes of colour variations — eight colours at 256x192 dots, 24 colours at 128x192 dots, eight colours with eight graduations with 128x192 dots, and black and white with four graduations with 256x192 dots.

The monitor will not, however, be available until the spring of 1981.

The new Sharp business computer will be ready for sale early next year. The PC-3200 consists of a QWERTY keyboard with a numeric keypad, user-definable keys and cursor control keys, an 80x25 green screen, dual-density, double-sided 5¼in. discs and printer which is selectable between 80 or 132 characters per line.

The maximum RAM capacity will be 64K bytes and the disc capacity at ½MB per twin disc. The printer and disc interfaces are built-in and include RS232. The screen is capable of reverse video and selected blinking and scrolling. Basic for the PC-3200 is in ROM, unlike the MZ-80K.

Down the aisle and round the corner on stand 8131 is Microsense, which is the U.K. Apple dealer despite rumours of Apple plans to start its own organisation. Microsense is making the formal U.K. announcement of the Apple III, providing most with their first opportunity to cast their eyes over the real thing.

Apple has added extra circuitry to extend the addressing capability of the 6502 allowing it to offer RAM options ranging from 96 to 128Kbytes. A 5¼in. floppy disc is built into the case and there is an option of daisy-chaining three or more on to the system.

## Latest accessories

Most Apple II programs will run on the Apple III without modifications, Microsense is also showing the Apple II again with some of its latest accessories and software.

Since most of the software on the market is now available and being written under CP/M, any move which makes CP/M software available for microcomputers based on the 6502 is not only innovative but also very useful. Apple users, and many others, will know that earlier this year Microsoft produced a Z-80 plug-in card for the Apple which allows users to switch between using the 6502 and the Z-80 and thereby run CP/M.

That is now available in the U.K. and is shown on the Personal Computers stand 2197 at Compec along with a CP/M disc. The Z-80 Softcard, priced at £250, also has a feature which allows a Z-80 program to pass control to a 6502 subroutine and then return to the main Z-80 program.

Other products which have received wide attention in the computer press, but which few people have had the opportunity to see or try for themselves until Compec will include the Transam

(continued on next page)

(continued from previous page)

Tuscan, on stand 7179. The Tuscan has been the subject of our series on computer design by Tuscan designer Mike Hughes. Transam is also demonstrating its version of Pascal which has been accepted by Commodore for the Pet computer.

Research Machines, Oxford-based purveyor and manufacturer of the successful 380-Z microcomputers, is showing its networking system for the 380-Z for the first time on stand 3185 with three or four distributed processors running from its new IEEE board under MP/M. It is also showing its adaptation

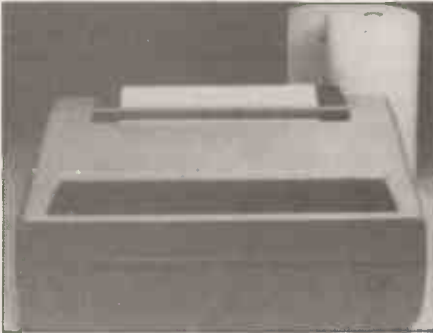

The Facit 4520 9x7 matrix printer will sell for £580.

of the Computer-Aided Design Centre's GINO graphics packages.

As reported in *Practical Computing*, Printout in October, GINOs perform a similar function for graphics as CP/M does for discs in that they provide a standard interface between the high-level software and the machine hardware and means that graphics software can be transferred from one machine with GINO to another.

If you think that the latest thing in small business systems is a microcomputer with a multiple-processor sharing centralised and expensive goodies like hard discs and printer, wander down to stand 9088 where Computer Centre Swansea is showing its OEM3, Z-80-based system running a DRI hard disc with multiple processors under MP/M.

### Apple II peripheral

Yet another peripheral for the Apple II microcomputer can be found on the Keen Computers stand 3115 where the Keenstar 14in. Super Colour Monitor is on show. It was developed for the Apple from the Keen Sony Super Colour TV. The Keen stand is also featuring the Keenstar microsystem, a 64K RAM S-100 bus microcomputer which is expandable to up to 64 terminals.

The DPSI front panel IEEE S-100 computers, from Ithaca Intersystems on stand 2186, shows some new features including a hard-disc subsystem and a colour graphics board. Also on show is its Pascal/2 native code compiler for Z-80/CP/M system which is useful when re-locatable object codes for ROM are required.

Mini-manufacturer General Auto-

mation has had a turbulent 12 months since the last Compec, with dramatic boardroom battles in the U.S. and many changes in the management hierarchy in both Europe and the U.K. including a newly-appointed boss of the U.K. operation. None of those wrangles seems to have affected its products and the U.K. team from Burgess Hill, Sussex are planning to launch a new range of micro- and minicomputers on stand 1145.

The range is for the U.K. market only and was designed and built by General Automation in the U.K. although the systems are based on its own chips. Of the three systems in the new range, the Boss 1, 2 and 3, only the Boss can be called a microcomputer. It is a single-screen, floppy-disc-based micro featuring a 128Kbyte memory and is intended for the small business first time user at a price of £6,000.

It will be sold through General Automation existing dealer network which will be expanded over the next few months. The General Automation sales talk will centre around the fact that it should be possible to start at the bottom of the Boss range and as required, upgrade to the Boss 3 and thereafter on to the rest of the General Automation range of minicomputers.

### New micro range

Another new range of microcomputers, due for launch at Compec, is from the Israeli firm, Elbit, whose terminals are already used by a number of manufacturers and are recognised easily. On stand 5172, it is introducing a microcomputer under the title of Micropact, a title not chosen to confuse you with Microact but a natural development of its existing Pact range which include Medpact, a medical software package, Keypact and Datapact.

The basic configuration of the Micropact will be the now familiar Z-80, 64K RAM, 5¼in. or 8in. discs, and S-100 bus and CP/M with four ports and a 15in. screen. The starting price of £1,800 for a system with dual 5¼in. drives seems about par for this type of equipment although Arthur Kennedy, managing director of the Elbit U.K. subsidiary, stresses that there will be an attractive discount structure for dealers, systems houses and quantity buyers.

As a public company, Elbit has some good names behind it. At least 30 percent of the shares are owned by the massive Control Data Corporation of the U.S. and CDC executives play a key role on the Elbit board. Elbit aims to sell between 700 and 800 systems in the first year.

Dedicated readers of the *Practical Computing* pages will remember that in February this year, we introduced a computer system which can be programmed in plain English, or as close to plain English as most computer people can approximate. Called Tina, the system is marketed by Unilever through its office

equipment distribution chain Beam which will be at Compec on stand 8166.

Tina has a limited vocabulary of about 40 verbs to which the user can add his own list of nouns. According to Beam, anyone can learn to program the system in a relatively short time. If nothing else, the demonstration at the exhibition should prove a useful opportunity to try the much trumpeted idea of query language programming.

If you find Tina the wrong size, you can always talk to her big and little brothers Abel, David, Adam and Goliath. Beam is also showing the Pertec PCC2000 Z-80-based micro with CP/M and the MT2 multi-user system linked through IBM protocols to the UCSL mainframe.

### Immediate interest

The Swedish company Facit, on stand 1110, already well-known for its stylish office furniture, quality typewriters, printers and computer peripherals is now limbering-up for an attack on the small business computer market. A look at its ergonomically-designed VDUs and keyboard will give you a foretaste of the desk-top computer it plans to introduce some time in 1981.

Of more immediate interest will be its new matrix printers which will be on show at Compec. Two 9x7 matrix printers, the 4520 and the 4521, have bi-directional printing with 60 lines of 80 columns per minute. They are controlled by a Z-80 chip and include character sets for 14

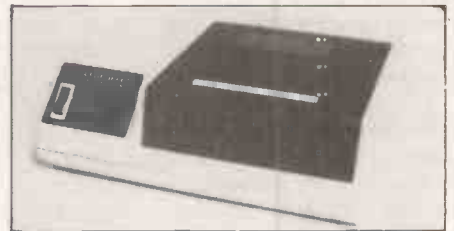

The Screen Image printer, from Centronics, was designed for vldetox.

European languages as well as U.S. ASCII. Prices start at around £580.

A more expensive new printer on the Facit stand, at £3,500, is the 4542 Graphic Flex-Hammer. It prints at 250 cps, in two colours, and with a microline feed and a 14x9 matrix dots can be placed in any position of the paper. It also features scanning, semi-graphics and 10 levels of grey to red.

X-Data is making a great show of the latest additions to the Oki line of printers on stand 4197. The Oki Microline is already one of the best-selling matrix printers and a price reduction has been promised to coincide with the launch of two new printers in the range, the Oki 82 and 83.

The 82 is a bi-directional version of the 80 with the additional features including form handling, formatting and improved interfaces, although it is still at 80 cps for its 80 columns.





1.2 Giga bytes of memory is as much as the Athena, on the Butel stand, can take.

The 83 includes all the additional features of the 82 but with a 136 column width and a speed of 120 cps, also bi-directional. The anticipated end-user prices are £550 and £800 for the 82 and 83 respectively, but they still have to be confirmed. Another feature of the stand will be the full range of TEC VDUs for which X-Data has just been appointed the exclusive U.K. dealer.

Still on the printer front, on stand 7156 Centronics is showing a selection of its range of dot matrix and band line printers. The Models 737, 6080 and 703 are all being exhibited in the U.K. for the first time. The Screen Image printer, developed specially for use with videotex and teletext receivers, will also be shown.

The Model 737 is a correspondence-quality printer, the second in the Centronics family of miniprinters capable of proportional spacing, using a 9x9 matrix, and mono-spacing using a 7x8 matrix. It also incorporates three-way paper handling, right-margin justification under software control, 96 character U.S. ASCII and five European character sets. It prints at 21 lpm over 80 columns and 58 lpm over 120 columns and prints sub- and superscripts.

## Print mechanism

Mannesman Tally, on stand 6152, is showing what it claims is one of the widest ranges of dot matrix printers in the world. One of its printers is the MT 1602 with a new print mechanism and a new print head with a double life, estimated at 200 million characters.

Options include a new nine-needle head

which produces improvements in the print quality. The Mannesman Tally latest comb matrix printer, the T3000, has three alternative matrix formats, controllable from software or from the front-panel switches. The T3000 HR prints at 300 lpm with a 7x7 half-space matrix and can be switched to a 7x7 whole-space matrix or a 7x10 full-space matrix.

## High-density graphics

Another printer company, Anadex, on stand 1121 is launching another new printer, an 80-column dot matrix. Called the DP-9000, the range will have a full high-density graphics plus alpha- numerics featuring descenders, underlining, condensed type and double-width printing. Adjustable tractor feed handles

After-sales support in a brief-case from HAL Computers.



up to A4 stationery and three built-in interfaces are standard.

More than one year ago, a company called Butel-Comco appeared on the scene in Southampton with a massive desk-top computer, the Athena. It is a hybrid system which includes an integral keyboard, screen, two tape decks, two 5¼in. drives, and a printer all in one. In its fullest form, the Athena can be expanded to have a total memory capacity of a staggering 1.2 Giga bytes.

## After-sales support

On stand 2228 Butel is, at last, coming on-line with some software including a suite of interactive Cobol business packages from around £550 and some sophisticated production-control packages called MAPS, both of which are claimed to be compatible with the Data General minicomputers. The Butel aim is to go for the big-machine packages in an attempt to bring good, old-fashioned serious computing to the micro.

Even those few companies interested in after-sales support will find something for them at Compec. HAL Computers, on stand 9042, is displaying the OASIS 820 portable test equipment. This is a micro test tool in a brief-case which can be configured to test virtually any computer peripheral by simply changing the application cartridge. Engineers can carry the OASIS with them, and test anything from floppy discs to displays and printers. The equipment costs around £950.

## Main attraction

A continuous demonstration of what a mains voltage conditioner can do about irregular voltage supplies and transient interference will be one of the attractions on the Cetronics stand, 1180. It has a microcomputer working from a distorted mains supply with a 1,500V spike on every cycle and show how their Reguvolt voltage conditioner can prevent hardware and software destruction.

The largest stand at Compec, 2206, has been taken by Canada, 11 of whose companies have clubbed together to book nearly 3,000 sq.ft. to impress the British, especially those with a disposition towards APL.

Of the 11 Canadian companies, six are showing microcomputer systems of which no less than four seem to specialise in APL, APL VDUs, APL time-sharing and stand-alone APL systems for Z-80-based micros.

Last, but by no means least, on stand 2131 you will find the staff of *Practical Computing* ready to answer your queries, listen to your mad ideas and sell the few remaining back copies of the magazine.

Entrance to Compec costs £2 if you turn up at the door, but only £1.50 if you send a cheque.

Make cheques payable to IPC Business Press Ltd, to Compec '80, 40 Bowling Green Lane, London EC1R 0NE. □

# WordPro™

## Word Processing Software

Everyone expected it would happen sooner or later... with WordPro it already has! Now all the marvelous benefits of an advanced stand-alone wordprocessor are available with the WordPro series of software and the systems they create.

If you've already been shopping for software in the crowded wordprocessing marketplace, you've probably determined the features you really want. You'll find WordPro has them, and more.

And if you haven't begun to shop yet, we urge you to compare, because only by comparison will you fully appreciate how complete and sophisticated WordPro software really is.

### WHAT MAKES WORDPRO THE BEST?

Our research has shown that while many wordprocessing packages have comparable features to WordPro, none can surpass Wordpro's EASE OF USE AND FLEXIBILITY. Wordpro operators need not be familiar with computer commands or functions. WordPro is easy to learn for anyone with ordinary typing skills.

### WORDPRO SOFTWARE IS LOADED WITH THE LATEST INNOVATIONS

Sophisticated systems programmed with leading edge wordprocessing features, WordPro is a series of programs designed specifically for use with the Commodore CBM/PET computers, peripherals and compatible typewriter quality printers.

### WORDPRO SOFTWARE HELPS CREATE YOUR OFFICE OF THE FUTURE

With WordPro you'll institute remarkable new efficiencies and time savings into your office procedures. Letters and documents can be quickly processed, free of errors and corrections. Edits and last minute changes are no longer a matter of annoyance and lengthy retyping sessions. The document is simply recalled from the memory, edited on the screen and reissued in crisp, finished form.

Using WordPro, work that used to consume hours now takes minutes. WordPro's easy editing capabilities and virtually unlimited filing capacity frees your staff from repetitive typing and tedious filing tasks. This enables them to devote their time to more productive and rewarding duties. They will find the whole business of wordprocessing an exciting task. And your company will see the benefit of that excitement paid off in increased enthusiasm and productivity.

### WORDPRO GIVES YOU THREE LEVELS TO CHOOSE FROM

WordPro software is a family of programs designed specifically for Commodore CBM computers, disk drives and compatible hardware (i.e. typewriter quality printers).



# Turn your Commodore CBM/PET computer into a highly sophisticated word processing system

WordPro offers three levels of sophistication, from WordPro 1, which is a basic text editing system, to Wordpro 4, which brings you virtually every important feature offered by dedicated word processors. Each level of software is extremely easy to learn... and just as easy to operate! WordPro software brings you the very latest advances in high speed, efficient wordprocessing.



**WORDPRO 1** is ideal for hobbyists, students and organizations who can benefit from the advantages of a basic wordprocessor without the program refinements of a commercially oriented system. WordPro 1 is recommended for use with the CBM/PET 8/16K, C2N cassette and a properly interfaced printer.



**WORDPRO 3** converts the CBM/3001 32K computer into a highly sophisticated 40-column screen wordprocessor. This program incorporates the advanced features considered important to effective wordprocessing, including nearly every entering, editing, memory and printing feature available today. WordPro 3 is recommended for use with CBM/PET 32K (40-column) computer, CBM Dual Disk Drive, and a properly interfaced printer.

**AVAILABLE FROM YOUR LOCAL COMMODORE DEALER.** Join the hundreds of lawyers, educators, manufacturers, and businessmen who have already installed this remarkable software... and see for yourself.

**WORDPRO 4** has it all! With this program, you will have everything you could want from a wordprocessor... and then some. WordPro 4 includes every feature found on WordPro 3, but with the added advantage of an 80-column display screen. The 80-column display simplifies text editing and makes entering text in columnar formats effortless. And with a few simple keystrokes, you'll be able to visualize on the screen exactly how your document will look prior to printing it out. WordPro 4 is designed for use with the Commodore CBM 8032 computer, CBM Dual Disk Drives, and a properly interfaced printer.

Phone or write Professional Software for  
the name of your nearest dealer  
**Professional Software**

2<sup>nd</sup> Floor West End House  
Hills Place  
London W1  
Telephone: 01-441 2397

Tim Robinson looks at three new software packages from The Soft Warehouse of Honolulu for Z-80- and 8080-based computers using CP/M or CP/M-compatible operating systems. They are muLisp-79, an interpreter for a dialect of Lisp similar to Lisp 1.5, with some notable extensions; muSimp-79, an interpreter for a Lisp-based, high-level Structured IMPLementation language; and muMath-79, a symbolic algebra system capable of routine algebraic simplifications, equation solving, symbolic matrix manipulations, differentiation, analytic integration, and much more. muMath is supplied with muSimp — the entire muMath system is written in the Simp language.

## Honolulu's innovatory packages

MOST microcomputer users write their programs in Basic. Its popularity stems partly from the small size of a typical interpreter, which allows all but the smallest system to support it, but mostly from the fact that it is very easy to learn, so that newcomers rapidly gain confidence with the computer.

Programs are developed incrementally, relying on the interpretive nature of Basic and the built-in line editing facilities. Contrast that with most other high-level languages such as Algol or Pascal which are compiler-based. Here, to make even the smallest change in the program, it is necessary to use a text-editor to change the source, followed by the compiler to translate that source into machine code, finally loading the output of the compiler for another trial run.

For a beginner, that procedure presents a significant barrier and even an experienced user would find program development tediously slow without a disc-based machine.

### Expressive power

What we need is a language with the expressive power of Algol, with a simple and uniform syntax making it easy to learn, and with the programming convenience of Basic. That is a tall order, but the muSIMP system takes a big step in the right direction. muSIMP is based on the language Lisp, but its outer appearance is totally different.

Lisp has been around for about 20 years during which time it has undergone extensive development, mainly in the hands of Artificial Intelligence — AI — researchers. It has become known as the machine language of AI and, as such, has been used to implement a number of higher-level languages in just the same way that the assembly language of a conventional microprocessor is used to write a Basic interpreter.

muSimp-79 is such a high-level language, and it frees the user from the peculiar syntax of Lisp with its profusion of parentheses, while retaining all the powerful features.

Since the underlying interpreter in Simp is very similar to muLisp, a brief look at muLisp is useful. If muLisp is similar to the dialect of Lisp known as Lisp 1.5, although there are omissions and some notable extensions.

Its authors claim that muLisp will

support serious research work on AI. While I think they are being overly optimistic in that claim, muLisp opens the door for the serious amateur to become involved in a very exciting field.

Here are some of the notable features of muLisp. For the benefit of those who have never encountered Lisp, I have included a few useful references at the end.

- There is no real arithmetic. In compensation, the integer arithmetic has almost unlimited precision and can be conducted in any base from two to 36. The largest number it will handle is about  $10^{611}$ . Internally, arithmetic is, of course, performed in binary.

- As new names are read into muLisp, they are given the value of a self-reference automatically. That is, if the name is used as a variable before a value is assigned to it, it will return that same name as its value. As if, in Basic, when you said PRINTS A\$ and A\$ was null, the machine displayed 'A\$'.

- The function COND is generalised to accept any number of expressions after each predicate, returning the value of the last.

- The body of a Lambda expression is an implied COND. Also, surplus Lambda variables are bound to Nil if no matching arguments are given in a function call. Together, these features obviate the need for most occurrences of COND and PROGN in Lambda expressions.

- With the exception of the PROG-GO-RETURN combination required to make iterative programming possible, Lisp was an exemplary structured language long before the term became idolised. muLisp implements none of these. Instead, there is a powerful multiple-exit LOOP which allows iteration in a pure applicative style.

- A function Condense is provided whose purpose is to permit the sharing of common sub-expressions in function bodies and properties. It can reduce storage requirements by about half, but is time-consuming.

- In all there are 83 built-in primitive Lisp functions.

- A final useful feature is that ']' is treated as a super-parenthesis which can be used to close any number of open parentheses. Surplus right parentheses at the end of an expression are ignored.

As an example of those features, consider the definition of MEMBER.

(MEMBER ITEM LIST) returns T if ITEM is a member of LIST and NIL otherwise. That function is included in the muLisp interpreter but it can, of course, be re-defined.

```
(PUTD MEMBER
 (QUOTE
 (LAMBDA (ITEM LIST)
 (LOOP
 ((NULL LIST) NIL)
 ((EQUAL ITEM (CAR LIST)) T)
 (SETQ LIST (CDR LIST))))))
```

In conventional Lisp this might be defined as:

```
(DEFINE (QUOTE (
 (MEMBER (LAMBDA (ITEM LIST)
 (PROG ()
 LOOP (COND ((NULL LIST) (RETURN NIL))
 ((EQUAL ITEM (CAR LIST))
 (RETURN T))
 (T (SETQ LIST (CDR LIST))))))
 (GO LOOP))))))
```

In the second version, DEFINE expects a QUOTED list of functions to be defined which accounts for the extra set of parentheses. A PROG is required, with RETURN to exit from the PROG when the value has been found, and GO explicitly to transfer control back to the label LOOP at the end of the iteration.

Note that while LOOP is a function in the first example, it is merely a label in the second. The MEMBER function could be written more concisely using recursion but I wanted to display the improvement which muLisp offers with iterative programming.

If you found the above definitions difficult to follow, compare them to the following:

```
FUNCTION MEMBER (ITEM, LIST),
 LOOP
 WHEN EMPTY (LIST), FALSE EXIT,
 WHEN FIRST (LIST) = ITEM, TRUE
 EXIT,
 LIST : REST (LIST),
 ENDLOOP,
 ENDFUN;
```

We see the same function in the muSimp language. Although it looks totally different, it is actually stored internally in exactly the same form as the muLisp version. CAR and CDR have been re-named FIRST and REST, EQUAL and SETQ have become the infix operators '=' and ':', and the WHEN...EXIT, LOOP...ENDLOOP and FUNCTION...ENDFUN constructs have replaced the Lisp functions COND, LOOP and PUTD. There is a great improvement in readability.

In addition to the usual prefix and infix operators of, say, Basic or Algol, Simp

also has postfix and matchfix operators. Some examples:

Prefix: unary — e.g. —3456  
 Infix: +, \*, AND e.g. A + 2 \* XYZ  
 Postfix: ! e.g. 7! (meaning factorial)  
 Matchfix: LOOP...ENDLOOP, BLOCK...ENDBLOCK

The operation of the matchfix operators is as follows. FUNCTION and ENDFUN indicate a function definition as in the example. Inside a function body, the statements are executed in order up to the ENDFUN delimiter unless a conditional statement is encountered in which the predicate, i.e., the first expression after the WHEN, is not FALSE.

In that case, control is passed to the body of the WHEN and ends when EXIT is found. In either case, the value of the function is the value of the last statement evaluated. LOOP...ENDLOOP is treated as a function body except if the ENDBLOCK is reached, control goes back to the statement after LOOP.

For a WHEN statement, the predicate is evaluated. If it is not FALSE, the body of the WHEN is executed up to the EXIT, whereupon control passes to the point following the next ENDLOOP, ENDBLOCK, or ENDFUN. If the predicate is FALSE, control goes immediately to the statement following the EXIT.

## Means of control

The purpose of the BLOCK...ENDBLOCK pair is to give a means of controlling where to go after the EXIT if you do not want to go as far as the ENDLOOP or ENDFUN. The first statement of a BLOCK must be a WHEN.

WHEN...EXIT and BLOCK...ENDBLOCK together are a generalisation of the CASE statement of other languages, which includes IF...THEN and IF...THEN...ELSE as special cases.

Associated with every Simp variable is a properties' list, which behaves just like its Lisp counterpart. Information is stored on this list with either the Simp command: PROPERTY variable, indicator, expression; or, from within a function, using the statement:

PUT (variable, indicator, expression) where <expression> is any valid Simp expression and <indicator> is a name. The information can be retrieved using:

GET (variable, indicator) which returns <expression>. Some very powerful techniques are possible using properties' lists and extensive use of them is made in the muMath package.

The Simp system comprises the interpreter and a bootstrap file called MUSMORE — MORE of MUSimp — which is read automatically when the system is loaded. MUSMORE contains the parser which translates the SIMP language on input for storage in the Lisp internal form.

The file begins in Lisp and as more functions are defined the text gradually changes until by the end, it is in Lisp.

Because the Simp parser is written in Simp, the user can define easily syntax extensions, new operators, or even re-define the system functions to suit his individual needs. While this can be hazardous, it offers possibilities denied to users of almost all other languages.

The muMath-79 algebra system is written entirely in the Simp. However it can be used by someone with no programming experience at all. In the examples, the "?" is the muMath prompt which indicates it is ready to accept a command. The user types a command or symbolic expression terminated by a semicolon. muMath evaluates the command and prints an "@" symbol on the next line followed by the answer.

muMath manipulates rational numbers exactly:

```
? (2/5 + 1/10)/3;  
@ 1/6
```

It understands the meaning of the mathematical constants e, i, and  $\pi$ , which are represented by E, I, and PI respectively:

```
? #E^(3*#I*PI/2);  
@ -#I
```

muMath accepts expressions involving undefined variables. Where Basic would signal an error, muMath treats undefined variables as mathematical unknowns and attempts to simplify expressions containing them:

```
? 6*X^3/(9*X);  
@ 2*X^2/3
```

There is a special variable #ANS, which always holds the value of the previous answer. To find the value of a variable, type its name followed by the semicolon terminator:

```
? #ANS;  
@ 2*X^2/3
```

The colon operator is used to make an assignment, as in Simp:

```
? FRED: 1/(A*X^2+B*X+C);  
@ 1/(C+X*B+X^2*A)
```

We can now refer to the expression by using its name, FRED. Note that in attempting to simplify the expression, muMath has changed the order of the terms. There are many built-in functions for performing mathematical operations on symbolic expressions. For example, to integrate FRED with respect to X, type: ? INT (FRED,X);

After a short pause, muMath asks: @ Is SIGN (4\*C\*A-B^2) — 1 \$ 0 \$ 1 \$ ? Replying with 1; to indicate positive sign, we obtain:

```
2*ATAN(2*X*A/(4*C*A-B^2)^(1/2)  
+ B/(4*C*A-B^2)^(1/2))/(4*C*A-B^2)^(1/2)
```

To simplify that, we can use the function FCTR which attempts to factorise its argument:

```
? FCTR(#ANS);  
@ 2*ATAN((B+2*X*A)/(4*C*A-B^2)^(1/2))/(4*C*A-B^2)^(1/2)
```

These few examples demonstrate just how easy muMath is to use, although some practice is needed when dealing with larger problems or expressions can easily become too large to handle. muMath offers interesting possibilities for

computer-aided teaching of maths in schools. However, its capabilities are limited and unlike the sophisticated systems available on mainframes, it is unlikely to be of serious use to research workers with big problems to solve.

The documentation supplied with muLisp is brief. While adequate for an experienced Lisp user, it makes no attempt to help the novice. After a brief discussion of the internal organisation of muLisp, it gives a description of each of the 83 built-in Lisp functions. There is a small program library which includes a trace package to assist in debugging.

In contrast, the documentation with muSimp and muMath is voluminous, extending to more than 200 pages. It is generally clear, but a rigorous definition of the Simp language is not given. A little experimentation, however, soon clears up any misunderstandings, and 10 interactive lessons are included for beginners.

The first five illustrate the use of the major commands available in the muMath system, while the remainder form an introduction to Simp programming. Running them will start you quickly even if you have no knowledge of Lisp.

The presentation of the manual could be improved. It is reproduced from the output of a dot-matrix printer in loose-leaf form in a ring binder.

## Conclusions

- I found Simp easy to learn and, on the whole, a very good language to use.
- Considering the limitations of 8-bit microprocessors — limited memory and slow speed compared to big machines — muSimp and muMath are most impressive.
- However, I have one major complaint. To conserve precious memory space, Simp does not incorporate any form of function editor.
- To alter a function it is necessary to re-type the whole definition.
- Alternatively, large programs can be typed into a text editor and the file so created read into Simp: while that is adequate, many of the advantages of an interpreter are lost.
- Fortunately, there is an interesting solution to the problem. It is the nature of Lisp-based systems that program and data are stored internally in the same form, as lists.
- Hence, it is possible to write a Simp function which, by manipulating lists, allows one to edit Simp functions — including the editor itself.
- While such a program needs more memory space than an equivalent editor written in machine code, it need be loaded only while a program is being developed.
- If space is short, the completed program can be saved and run in a Simp system without the editor.
- My first major project with Simp was to write such an editor and it gave me great insight into the inner workings.
- I highly recommend muSimp and muMath. □

NOWADAYS, the arrival of a new 64K micro on the market is almost a daily event. However, when that product bears the name IBM, one must look at it in a different light to the run-of-the-mill offerings.

IBM, of course, needs no introduction as a large computer manufacturer and supplier of typewriters. The fact that it markets a vast range of intermediate products is not so well known. In the mid seventies, IBM realised that to attack the smaller systems market, it would need a different approach to that offered by its large systems division.

It felt, and I think rightly, that this approach would be better served by establishing a part of the company to deal with not just the smaller user, but also the users of its smaller machines.

As a result, it formed the General Systems Division which is independent of the Data Processing and the Office Products Division and, in fact, can be in competition with them in some areas.

The first IBM machine to attack the micro market was the 5110, it had very little built-in software and made little

by Nick Horgan

impact on the scene. The new machine, the 5120, is a much re-designed version of the 5110, and will run most of the software from the earlier machine. It is designed to sell both to existing IBM mainframe users and to the first-time buyers.

The machine is very solid; it weighs 120lb. and, with no hand-holds, even two people would not want to carry it very far. Aesthetically, the 5120 looks rather strange with its small screen and offset keyboard.

The screen is high on the left side of the box, allowing two 1.2MB drives to be side by side on the right. The keyboard is attached to the main box on the lower-left side, and in the middle of the front panel, in descending order, are three switches. The top switch allows display of the register contents on the VDU and is mainly for engineering use but is good fun to watch.

The middle switch is for a re-start and would be used mostly when switching between APL and Basic with the third switch. A brilliance control and an on/off switch complete the controls on the front cover.

At the rear are three sockets which are used for communications, and for connecting the system printer. Two standard printers are available; the 120 cps and the 150 cps. Both are bi-directional matrix printers allowing sprocket or cut-sheet feed.

All in all, once you have grown accustomed to the initial odd look of the machine, the system feels and looks well engineered. A quick look inside the box revealed a standard IBM type layout. Again, the impression was one of standard and well-tried methods.

# Numerous system services lift IBM 5120 above its competitors

Apart from the two printers the computer has 16K, 32K or 64K. The two integral discs are 1.2MB each and a further 2.4MB may be attached externally. The user can either select a version with APL and Basic in ROM, or, if preferred, a system with Basic only. When asked to review the 5120, I was looking for something special. I was not, on the whole, disappointed.

Like most micros, the installation is simple; plug in and go. We did — it didn't. The gloom soon lifted when the problem was traced to a blown fuse in the plug. IBM plugs, by the way, are well designed; you can change fuses without taking the plug apart and the plug top has a loop in it to assist in pulling it from the socket. We never discovered why the fuse blew, and that was the only hardware fault we found.

The version of the machine I had to test was the 64K Basic/APL model. Both the Basic interpreter and the APL are in ROM and are switch-selectable from the front panel. That one fact in itself is enough to lift the 5120 above most of its competitors.

The pros and cons of having Basic or APL in ROM are that it frees all the RAM for you to use, at the expense of being stuck with whatever version of the software the manufacturer thinks you need.

Depending on the position of the APL/Basic switch when you either power-up or press the re-set switch, the system will start-up in the selected mode. Changing from Basic to APL and back takes about 30 seconds. You change the Basic/APL switch, press the re-start key and wait for the system to cycle through a memory check. The memory check is also performed after the initial power-on.

## Striking features

The first thing you notice after switching-on is the small size of the screen which is, without a doubt, the worst feature of 5120. At a time when, for example, Commodore is changing its 40-column screens to 80 columns, it seems very strange that IBM should produce the 5120 with 16 lines of 64 characters. The best way to look at this feature is that 5110 users will be over the moon to have such a large screen.

The second striking feature is the key-

board, which looks extremely complicated. The major reason for this is the use of APL which, for those of you who are not aware, uses all kinds of non-standard, e.g., Greek and mathematical characters.

To say that the keyboard was being used to the maximum is an understatement, almost all the keys have five functions:

- Upper-case alphabetic
- Lower-case alphabetic
- Basic commands
- APL commands
- APL special symbols

You can select the function you require from the keyboard using various combinations of control keys. Most of the common commands can be entered with a single keystroke, e.g., print, run, etc., and the keyboard itself is very easy to use. In fact, I would say it has the best feel of any I have tried.

Some of the characters needed by APL have to be created using two overtyped characters from the keyboard. For example, the exclamation mark, although not an APL character, has to be created with a typed bar, followed by a back space and a fullstop.

## Memory mapping

The ability of overtype characters brings us to one of the best features of the screen — it is memory-mapped. The big advantage of that is that the CPU considers the VDU to be a part of its memory which enables you to use cursor-control keys to edit information directly on the screen.

The disadvantage is that the CPU has to keep the VDU refreshed all the time. That task can take up to 30 percent of the available processing time from the CPU, with a consequent decrease in program run-time. IBM has gone some way towards solving the problem by letting the programmer turn the screen off for long, e.g., sorts, processing programs. That can be slightly annoying for the user who is confronted with a blank screen and does not notice the process light flickering.

The home position for the cursor is the bottom-left of the screen. The display is small but crisp and I found no trouble reading it in normal light conditions.

I first tried using the machine in Basic — not a very happy experience. Having used a number of Basics, did not bother to

read the Basic manual before inputting:  
10 TEXTTS = "ABCDEF":PRINT TEXTS

As soon as I pressed the enter key, the screen started flashing, an error number appeared under the Basic line, and an upward arrow pointed to the part of the Basic statement the interpreter did not like.

The Basic line is syntax-checked when you press the enter key, rather than — as with most Basics — at run time. That is reasonably useful, and when coupled with the upward arrow pointing to the character Basic does not like, it provides a fast method of ensuring that the statement format is correct.

As I could not see anything wrong with the statement, I thought that the time had arrived, when all else fails, to read the documentation.

For those who complain that they are not supplied with enough documentation, the 5120 is for you — the Basic manual is 600 pages long. The standard of the documentation is very good, as one would expect from IBM. Three sections constitute most of it:

- Introduction
- Reference manual
- Hints and advanced techniques

Those divisions are also used for the applications packages. All in all, the

system is supplied with more than 1,200 pages of documentation varying from operator instructions through Basic and APL, to various back copies of IBM newsletters.

It is obvious that IBM has gone to great lengths to ensure that a user, left to his own devices, can start to use the 5120 as painlessly as possible.

It was during the reading of the documentation that my attitude to the 5120 changed. Having worked on a number of micros and on most IBM mainframes, I have always imagined the micro-user toiling by himself manual in hand, while the large mainframe user has all the in-house back-up he could need.

### Larger user

The more I grew to know the 5120, the more I found myself thinking about it in terms of the larger user. Whether that was due to the familiar IBM-style documentation, or, the complexity of the system, I do not know.

That is not to say an individual could not use the 5120, but I doubt that he would have the resources to explore more than 20 percent of the machine's capabilities. Two other factors influenced my general feelings about the machine.

Firstly, its ability to communicate with

most IBM mainframes, and secondly, the way all my colleagues, who have become immune to the various computers which appear in the office walked through the door with a cheery: "How's the IBM?" There is no escaping the fact that I was not just testing a microcomputer but an IBM microcomputer.

Although the 5120 does not have an operating system as such, all the software can make use of numerous system services. Those facilities, more than anything else, raise the 5120 above any comparable micros.

The CP/M user can, by buying software from various suppliers, duplicate most of the 5120 functions, but he will have all kinds of interfacing problems.

Apart from simple commands that format discs and make file copies, there are three main areas where the system helps the applications programmer.

The first is the procedure file: that allows you to set-up a batch of commands to be executed in a given sequence. A rather neat way of setting-up the file is to use Basic to create it in the same way you create a program. You tell Basic that you want the program saved as data and all the Basic sequence numbers are stripped-off prior to the file being saved.

*(continued on next page)*



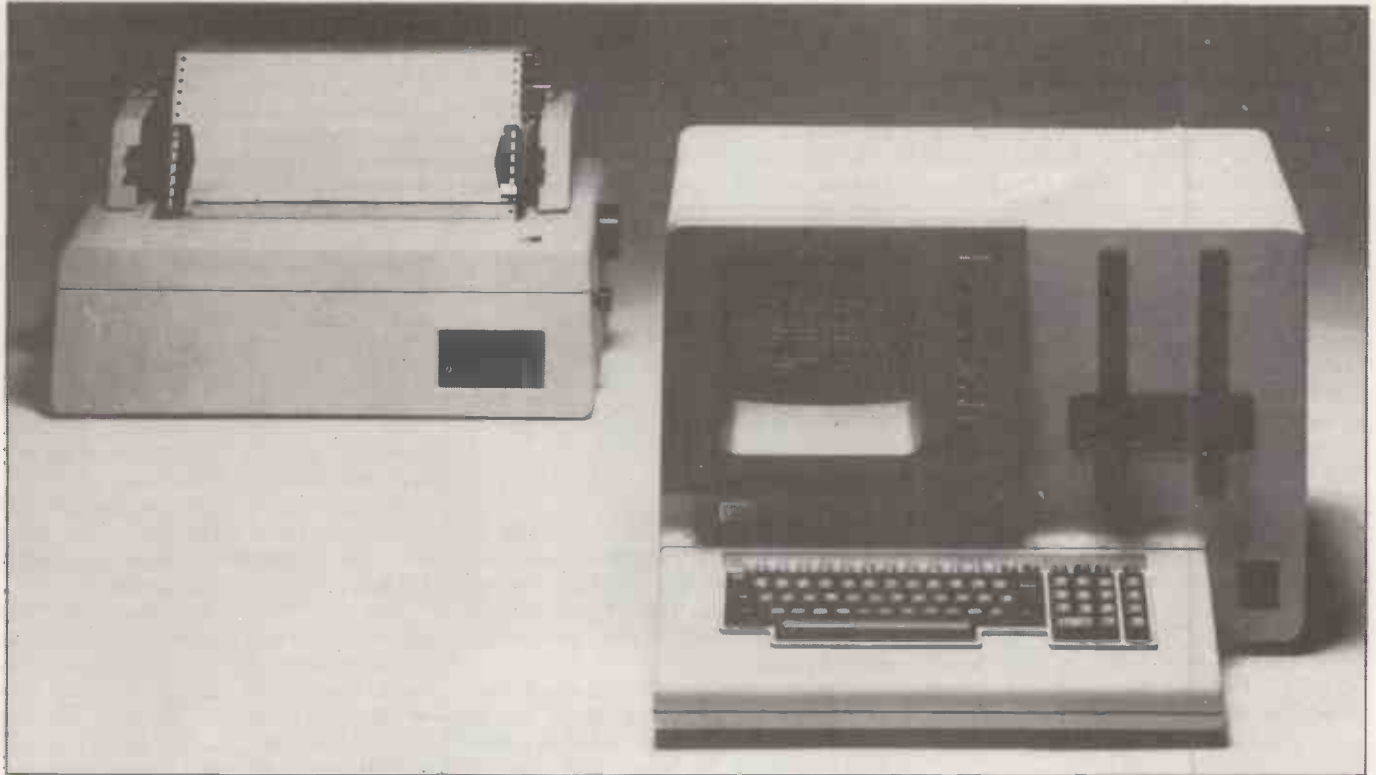

(continued from previous page)

Procedure statements may be branched around either unconditionally or conditionally using a return code from the program. Variables may be included in the procedure, e.g., file names, etc.

Next and almost as important is the diskette sort utility. It allows data to be sorted on up to six fields with a maximum total length of 64 characters. Each field can have a different data type, being character or five types of numeric.

Either the whole file may be sorted or a tag — address out — sort can be requested.

The sort parameters are easy to understand and may be created dynamically using Basic or APL. There are four methods of data storage

- Stream files
- Sequential record
- Direct record
- Key indexed

Stream files store data in variable format; individual data items are separated by commas.

### Sequential records

In sequential records, data is stored in fixed-length records and may be accessed sequentially forwards or backwards. The file is normally in sequence by key with new data being added either at the end of the file or during a file-to-file copy.

With direct record, Data is stored in fixed-length records and may be updated using the relative record number. The file may also be processed sequentially, starting at any position in the file.

Keyed indexed is the big one, as far as applications are concerned. Each record can be retrieved by up to a 28byte key. The system keeps track of indexes, over-

flow areas, etc. As well as access by the whole key, you can specify just the first part of a key and perform a sequential search. To speed access, the highest level index can be called into memory.

It is a pity that the system does not allow duplicate keys, although with the various facilities available, you should be able to program around the problem.

The first few pages of the Basic manual proved very disappointing, and included the following limiting features.

- Basic variable names are restricted to one character and one numeric.
- Statement numbers vary from 1 to only 9,990.
- You may have only one statement per line.

Compared to most Basics, those restrictions are unbelievable. A final disappointment was that not only do you have to initialise discs prior to use, but you have to pre-allocate any files you will need, with a utility command called MARK.

I can see the advantage of having your files pre-allocated for speeding disc searching in a production environment, but for testing, it is annoying.

At this point, had the micro not been an IBM and had the documentation not pointed out all the other options available, I would have decided that the system was overpriced at approximately £6,000 plus printer. However, from that point on, things improved dramatically.

Even if you know Basic, you should read through the Basic manual. Like all IBM products, the interpreter treads the thin line between sophistication and complication. Most of the commands have vast numbers of options, particularly in the matrix operations.

If you are a seasoned IBM user, you will appreciate the proliferation of various kinds of brackets in the MAT PRINT statement — it takes 10 pages of explanation in the manual. With those reservations, the Basic is superb with full matrix operation, and good print and screen-formatting options.

A program was shown which enabled you to obtain a cross reference of variables and commands; it is so useful that it should be part of the Basic structure.

### Error trapping

Error trapping is also very good with more than 200 possible error codes, all of the ones I obtained were even in the manual. Programs may be chained, and data passed using common variables. Programs can be saved in locked mode. That prevents listing or alteration of the Basic program — a very useful facility for a commercial environment where copying of programs is a real problem.

All the normal Basic commands are available. AUTO RENUM, TRACE, etc. The ability to route all printer output to the screen using the run statement proved its worth when evaluating the applications software that was supplied with the system.

The numeric numbers on the numeric pad can be used as function keys. They are not just the normal function keys which return a code to a program — as usual, IBM has gone a few steps further. You can program any of the nine keys in one of three ways.

- To execute a system command.
- To execute a pre-defined series of Basic statements.



● To hold a character string which can then be inserted into the current line on the screen, e.g., you can set-up a function to convert between Hex and decimal, assign it to one of the numeric keys and, by supplying the argument, press one key and obtain the answer.

I am not an APL programmer, and am, therefore, unable to pass judgment on the IBM version of APL. However, having long wanted to use APL, I felt that this was a good time to devote half an hour to trying it.

Five hours later and half way through the introduction to APL, I was living proof that, for a first-time user, the documentation really works.

An interesting point that struck me was that a machine with APL — which is very strong in matrix operations — should also feature a Basic which also has the most advanced matrix operations I have encountered.

If it is IBM, the 5120 will communicate with it or emulate it. I can imagine that existing IBM users will have been made aware of the facilities available with the 5120 to communicate with their equipment. It will communicate with all the IBM mainframes and with another 5120 via bi-synchronous or synchronous ports. It will emulate a 3741 or a 2770, and can communicate with punches, etc., via a RS232C port.

As a rule, IBM does not supply commercial packages with its systems; the user is left to program or to go to a third-party software house.

## Blurred distinction

The neat line between application packages and system utilities is becoming rather blurred in the case of information storage and retrieval. However, with the 5120, IBM has gone all the way and produced a comprehensive commercial package of:

- Accounts payable
- Accounts receivable
- Nominal ledger
- Stock control

They may be used on a stand-alone basis or a total system.

BRADS, or business report/application development system, is a complex program suite which can be purchased with the 5120 to store, update and retrieve all types of information. The complexity of the system is hidden completely from the user who interacts with it via a series of menus.

In a large number of data processing applications, it is required to hold, update, enquire of and report on lists of files of data. Common examples of that are:

- Personnel lists
- Stock files
- Component lists
- Registers, etc.

BRADS allows the first-time user and the experienced programmer to create those applications in a very short time. The documentation consists of an introduction and a reference manual.

The introduction is a very well laid-out book, consisting of screen lay-outs, print

lay-outs and amusing cartoons. It starts with how to turn on the 5120, how to load diskettes and how to enter the computer into BRADS. It continues with two clearly-explained examples, and by the time the user has finished, say, between five to 10 hours, it should be possible to write a simple application.

To anyone used to information storage and retrieval systems, the sequence of operations is familiar. For those to whom it is a new method, there are five basic steps:

- Define the name of the file and what it is to contain to BRADS, e.g., file is stock file and data will be stock name, level, etc.
- Tell BRADS how you wish to access the file, e.g., by stock name and by supplier.
- Input information according to the first step. You will be prompted for correct information by BRADS at each point in the update.
- Calculate and tell BRADS how you will select information, e.g., all records where stock is below minimum stock and supplier is Smith & Co.
- Define the various print lay-outs you require.

All that is done using a question-and-answer session. Needless to say, BRADS makes good use of the sort and indexed sequential facilities on the 5120, allowing report sorting and complex file structures.

That only scratches the surface of BRADS which has a large number of facilities including the ability to add Basic to a BRADS application.

Most microcompanies would call BRADS a database management system. I am glad to say that IBM has not done that because powerful though it is, to write a payroll system would not really be possible without using a large amount of Basic. However, BRADS would be of such enormous help for most people that I cannot imagine many buyers going without it.

I shall not go into depth about the accounts receivable system, but try to give some idea of how IBM packages its applications software. The packages are of U.S. origin but have been changed so that they fulfil the statutory requirements in the U.K. That is satisfactory as far as it goes, but the documentation is still full of MMDDYY and ZIP codes.

The manuals are complete with two cassettes which lead you through the documentation. The instructions and examples are excellent, taking the user from the setting-up of the system through to how and when to process information. Every facet is covered, for example, among the chapter headings you will find: Computerise accounts receivable — a plan of action  
Training operators  
Obtain supplies  
Conduct parallel run  
Setting-up manual controls

The instructions are easy to read and are contained in handy, small-size reference books. It all fits in with the general idea of the 5120, in that you should expect

to spend time reading the manuals and trying the examples before using it in earnest.

The accounts receivable package is comprehensive, containing the following reports:

- Statements
- Trial balance
- Over credit limit
- Outstanding invoices
- Past due invoices
- Customer master file print
- Account status report

Open-item or balance-forward accounting can be selected by customer. All in all, a well-constructed, excellently-documented system which should be easy for a first-time user to set-up and run.

## Conclusions

- The 5120 should be assessed as a total system including the system utilities, APL and Basic, and the communication facilities.
- If the prime marketing aim of IBM is to use the machine to stop its existing users going elsewhere for their micros, they have the design and price exactly right.
- If the marketing aim is to set first-time users on the IBM path, I am not so sure of its success; where the existing user would see worthwhile facilities, the first-time user could well be put off by the complications.
- As far as the price is concerned, for a 2Mbyte system with 64K and a 120 CPS printer the approximate price would be £8,500. Application packages work out at about £1,000 a piece, and delivery is immediate.
- There is reputed to be a large amount of software available from the 5110, and there are a number of systems houses who will write software for the 5120.
- The small screen, and rather reduced Basic facilities regarding variable names, etc. were disappointing.
- The documentation was excellent and stretched to more than 1,200 pages. Switching from Basic to APL and back is very easy, and could prove a boon in mixed commercial/scientific work.
- The command structure in Basic was very comprehensive.
- Having procedures, a sort, and indexed files makes application programming very productive.
- BRADS is a good information storage and retrieval system, and should prove popular with experienced and first-time users.
- Communications with other IBM products is as good as any user could wish.
- A solid, very comprehensive micro with an integrated-systems approach. It is going to cause problems to other vendors trying to break into existing IBM users at the micro level.
- There seemed no easy way to expand beyond the 4.2M of floppies on to hard discs or indeed any other IBM machine.
- For a single-user system, the price is on the high side, but if security of supplier is what you need, obviously you cannot do much better than IBM. □



# The Acorn Atom

THE QUESTION uppermost in my mind when I first received Atom for review was: "At whom has Acorn aimed the machine"? I took delivery of the machine in a cardboard casing measuring 17in. by 12in. by 4in. which housed the unit supported by foam mountings plus the three necessary electrical cables and the single accompanying manual.

The computer is of the single-unit type — a formed plastic shell supporting the processor, memory, interfaces and a full-sized QWERTY keyboard. It is also small enough to pack into an average-sized briefcase. Having no built-in display or printer, the Atom uses what surely must be the best method of output for low-cost systems — direct connection to the aerial socket of a domestic TV set.

After unpacking the unit, and turning to the manual, I met the first snag; there was no indication anywhere as to what voltage should be applied to the power line. Fortunately, there was a note written on the transit box: "Needs 5V — two 2.5V batteries". So I duly connected it to my own clean 5V supply. In fairness to the manufacturer, I learned subsequently that the review machine was a pre-production model although the manual supplied was, in fact, the latest edition.

## Hardware components

Establishing that with the correct power applied, the unit gave the proper prompt when connected to the TV, I turned my attention to the hardware components. The available configurations range from the minimum system which is an 8Kbyte monitor plus 12K byte RAM. The review system had the 12Kbyte monitor and 12Kbyte RAM.

The expanded system also supports a

floating-point option which was included in the review machine. Without that option, the user is limited to using integer-only arithmetic. Having verified that the machine functioned correctly, it was time to look inside and examine the architecture. The nucleus of the Atom is the 6502 processor chip, now established as one of the standards, at the heart of the

---

by Jim Murray

---

Apple, the Pet and the Rockwell AIM systems. For the assembler programmer, the 6502 instruction set provides some useful facilities especially in its addressing modes, and the idiomatic Basic provided with the Atom denies the Basic programmer very few of those facilities. Memory was provided using 24 2114 4K static RAMs.

Input/output other than through the built-in keyboard, TV VDU and cassette channels was through a 6522 VIA — versatile interface adaptor — which provides two parallel ports, interval timers and a serial/parallel converter. Finally, the display processor was a 6847 which allowed a range of display options, all user-selectable using the standard software provided.

Eight graphics modes are available in all but only the base level mode — mode 0 — is available on the unexpanded machine. In that mode, the screen is structured as 16 lines of 32 columns — each character is either one of the standard 64 ASCII set or one of the standard 64 special symbols created from a six-element Pixel.

The ASCII characters can be displayed either in the standard way — white on black — or in reverse video, and the

special symbols can be shown as black and white or black and grey. Mode 0 allows the full range of allowed characters and symbols to be displayed simultaneously. The higher graphics modes provide progressively higher point addressing on the screen up to a maximum resolution of 256 by 192 in black and white or 128 by 192 in four colours. However, the higher-resolution and colour facility has to be paid for by the use of up to 6K of the user RAM.

I approached the user manual with some degree of trepidation. For, as many may have experienced, some manuals supplied with hardware and software products are grossly inadequate, others are little short of disgraceful — hastily-produced adjuncts to the product they describe.

## Users' manual

No such criticism can be made against the Atom manual, although the title is inaccurate, or at least misleading: "Atomic theory and practice — a beginners' course in Basic and machine-code programming". It implies that, having mastered the contents of the tome, the raw beginner would have acquired a command of both the Basic and 6502 assembler languages.

I feel that to be misleading for two reasons because the version of Basic provided with this machine is highly idiomatic and there are more concepts involved in writing assembler or machine-code programs than are introduced in this manual.

The risk is, therefore, that the beginner might emerge from his thorough study of the Atom monitor as taught by the manual, under the misapprehension that he could program in a standard Basic and

even start work with a standard assembler.

With those reservations, it must be said the manual, as an explanation of the Atom monitor, is a masterpiece of clarity — full marks go to David Johnson-Davies for his very readable and instructive work.

There are three sections to the book, dealing with Basic, assembler and general reference points. Each section is neatly divided into chapters, each of which addresses one concept; there are 27 chapters. In sections one and two each chapter then follows the same pattern: a friendly introduction, aimed at the less-experienced reader, explains each new point — loops, arrays, strings, etc. — then coding is defined and finally a set of examples presented.

The worked examples distributed throughout the manual are worthy of a special mention. A wide range is presented and within each chapter, they vary from the simple, which illustrate well the chapter's central theme, to those which present methods using the theme which many career programmers could usefully add to their repertoire of techniques.

A thoughtful overall introduction is provided at the beginning of the manual which suggests a reading for those of different skill levels. The 10-page index at the back of the book is comprehensive.

### Important concept

The three software components of the system are the monitor, the Basic interpreter and the assembler. The assembler is accessed through Basic which in turn is accessed via the monitor.

The monitor effectively manages a dynamic area of memory called the text space which grows or shrinks as text is added to or deleted from it. Any user input line preceded by a line number goes into the text space either as a new line or to replace an existing line with the same number. The text lines are sorted on line number as generally the text space will hold the currently-active program — either Basic or assembler.

An important concept is multiple text spaces. At any point, the user can re-define the start of the text space he wishes to manipulate and can thus have resident in memory several areas all containing lines with the same range of line numbers. Those text spaces may perhaps hold programs or there may be a mixture of programs and data. Regardless of what they hold, however, only one can be active and accessible by the monitor at any time.

The monitor thus acts as the text space — program — editor, but the only facilities offered are whole-line replacement and selective lists. There are no utilities which provide string searches, string replacement of re-sequencing.

The manual provides, however, an example of a program in a secondary text space which re-numbers the main program, resident in the primary text space an enterprising programmer may wish to equip himself with similar utilities to

emulate his favourite editor before embarking on a major project.

Text spaces are saved and loaded to and from cassette tape via simple monitor commands which allow the user to assign file names to the tape files, the encoding format being CUTS — or Kansas City Standard — with a reasonably modest fixed speed of 300 baud.

I tried three different cassette recorders to test the cassette system. They varied in price from £25 to £55. Only on the most expensive recorder did I achieve consistently trouble-free data transfer.

While it might be argued that a good quality recorder is a good investment for those wishing to use it for off-line data storage, I feel one must consider the position of the purchaser of a low-cost system such as the Acorn Atom. To him, the cost of upgrading his tape recorder must represent a large proportion of the total cost of the system.

I believe, however, that the explanation of this particular fault lay once again in the fact that I was using a pre-production system — I saw another later Atom connected successfully to a low-price recorder.

The general point is obvious: the buyer of any piece of technical equipment must satisfy himself that it is fully compatible with components he already owns and wishes to use with it.

The Atom text space can contain any data the user wishes to enter. So, when the data is, in fact, a program, no syntax checking can be performed until the run command is issued. At this point the text is interpreted as Basic.

While many, if not most Basics on small machines have eccentricities and can be said to be non-standard, some are positively more non-standard than others. The Atom Basic is definitely non-standard and that, I think, is due to the strong link between it and the built-in assembler.

The user is provided with 26 simple variables, A-Z which when undimensioned can hold either a four-byte integer

or four-byte floating-point number if the floating-point option is included. Note that numbers are held in binary, not as ASCII strings, which, of course, makes for higher-speed arithmetic calculation. Thus, the default precision is 32 bits but examples in the manual indicate how to manipulate numbers of arbitrary precision if this is needed.

If the simple variables are dimensioned, they are assumed to be byte arrays, holding numbers of eight-bit precision or, more normally, character strings. Those arrays must either be pre-defined or assigned dynamically to unused memory above the program space at program run time. In practice, there is not much difference between the standard dimension statement and dynamic assignment.

### Array variables

An additional 26 array variables, AA - ZZ, are also provided to hold word arrays. In Atom terms, a word is the four-byte unit. Arrays can have only a single dimension. That appears restrictive until the concept of indirection and word vectors is introduced.

Indirection is a concept more familiar to assembler programmers than to those who normally use Basic but all it means is that a variable contains not a value but a pointer to a value which is held elsewhere. Atom Basic allows word vectors to hold such indirection pointers to other arrays or vectors. Thus, multi-dimensioned arrays can be simply constructed as arrays of arrays.

Admittedly, the penalty is a certain lack of clarity in the program but the bonus is that the inventive programmer can construct rich data structures found usually in the more powerful languages. Naturally, the Atom Basic provides new operators to deal with these structures.

In the same vein, string variables are handled in a way which pays little allegiance to the more traditional methods, but once again, all the regular string manipu-

*(continued on next page)*

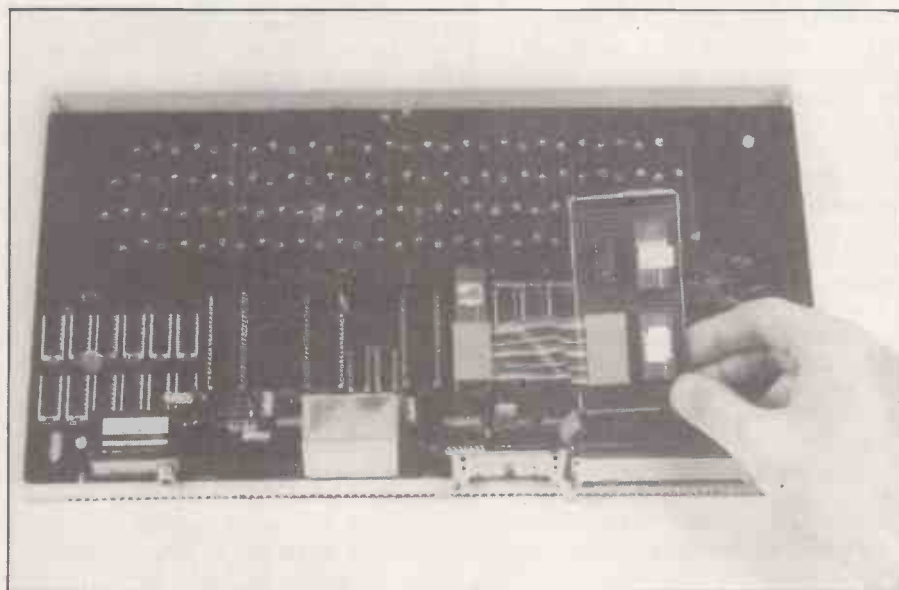

(continued from previous page)

ation functions are either present or can be very simply constructed. I must admit that initially, I found addressing the various data types rather awkward but after realising the strong association with the processor addressing modes, normally evident only when programming in assembler, all became clear.

The next point of interest was the structure of the executable program statements. Although the screen width is only 32 characters, a Basic line can in fact be 64 characters long. On the screen, the line wraps around after the 32nd character automatically.

Each line can hold as many statements — separated by semicolons — as will fit, and when one statement is an IF test, either all the remaining statements on the line are executed or none, depending on the result of the test. That, of course, helps the programmer as he can dispense with many short conditional GOTO branches whose only purpose is to include or omit a few lines of code. It also enhances the readability of the program.

### Reserved words

Another feature, however, while just as valuable in other circumstances detract from the program's readability. That is that most reserved words can be reduced to one or two, sometimes three characters. A multi-statement line using the abbreviations can thus be reasonably complex, and the decision to write clear or concise code is in the hands of the user. A spin-off here is that a powerful immediate mode command can be input and can even involve more than one level of FOR NEXT loops. Immediate mode commands are a feature of most Basics and normally allow the user to execute any single-line statement which contains no reference to another line without having to declare that single line as a program.

On the subject of loops, the FOR NEXT STEP construction naturally is present, augmented by the more recent DO UNTIL variation and FOR NEXT, DO UNTIL plus GOSUB RETURN sections can be nested to a depth of 15. GOSUBs have two interesting peculiarities. Firstly, the target line — or the target line of a GOTO — can be referenced by a label as well as by line numbers. That, of course, makes the program insensitive to line number changes and, it is claimed, results in faster execution of the program. Indeed, a simple two-line example program which produces a continuous tone on the internal loud speaker proves this, since the variation using a line number as the GOTO target produces a lower note than the variation which uses a line label.

Secondly, GOSUBs can be recursive. For those not totally familiar with recursion, it is simply the concept of a sub-routine calling itself. Many classic problems can be very elegantly formulated using this concept and several useful

examples are given including the Eight Queens' problem and the Tower of Hanoi, and mercifully excluding the totally useless evaluation of factorial.

Both the Eight Queens and the Tower examples show a continuous graphic display of the solution steps and it is perhaps illuminating to note that both can be run on the minimum 512-byte, user-RAM configuration.

The continuous display brings one to the graphic capabilities of the system which must be a major attraction to potential buyers. The ranges of resolution, or point addressability, mentioned and three verbs, MOVE, PLOT and DRAW, are available which produce point to point movements of the graphics cursor.

If the graphics is to be used, there are two options, one of which illustrates another neat feature of the system. If the extension ROM which processes the fourth verb — colour — is not present, the user can supply his own subroutines which process the MOVE, PLOT and DRAW verbs. That is possible by the monitor placing the default addresses for those routines in accessible RAM even though the routines themselves are in ROM. The user can, therefore, re-direct the interpreter to use his own supplied routines in preference, by adjusting the ROM pointers.

That technique is also available for other system-supplied features such as error-message processing, so for instance, in this case, the programmer might choose to try to recover from an otherwise fatal error alternatively, he might choose to produce a more specific message than the systems default.

In general, the documentation is very clear about the monitor and which memory locations can be manipulated to adjust its features and operation. Relevant to that, I was glad to note that the abominable Peek and Poke commands had been relegated to the scrap-heap and replaced by a much more elegant idea.

If a variable — holding a value which is a memory location — is preceded by a '?', the expression is interpreted either as a Peek or Poke depending on its context. Thus, for example, in the statement "?L = ?L + N", the "?L" at the left-hand side of the "=" is interpreted as a Poke while the other occurrence is interpreted as a Peek.

For the assembler programmer, access to the assembler is gained through Basic. Two special symbols, '[' and ']', are used to enclose assembler statements within a Basic program. When, during the run of the program, those statements are encountered, they are not executed, but assembled.

The location into which the machine code is placed is governed by the Basic variable P which is manipulated by the assembler just as a regular location counter or which can be adjusted by the Basic program. In fact, the variables

available to the assembler programmer are identical to those available to the Basic programmer. Naturally, there is a Basic command available, LINK, which transfers control from Basic to the machine code, but there is a much more important use for writing assembler statements within a Basic framework.

Since the assembler blocks enclosed by the brackets assume the same status as an ordinary Basic statement, the higher-level language can control the selective assembly into machine code. That is, condition tests in Basic can determine whether or not a given section of assembler code will be included in or excluded from the assembly.

The systems developer who may wish to produce several versions of a machine-code program, each with its own local variations can therefore use Basic to formulate the individual options, and select those options required perhaps by a question-and-answer preamble at the beginning of the control program.

Using similar methods, macro statements, i.e., groups of assembler statements referenced by a name, can be built easily. The two utilities of user-defined macros and conditional assembly provide the developer with a powerful tool found normally in much larger machines.

### Conclusions

- The Atom is a low-cost modular and expandable system.
- The software provided derives from a creative approach to mixing Basic and machine code, although criticism of the dialect of Basic included would be very understandable.
- Most buyers will be hobbyists, educational establishments, or perhaps engineers.
- The machine will make less impression in the immediate future on the commercial market. Two developments in the pipeline promise, however, to change that.
- The mini-floppy option should be available soon. If the company sticks to the target price of less than £200, a disc-based system with colour graphics for around £450 will certainly open new markets, making the machine very attractive to the small business user.
- The second development is a combination of several machines into a market based on the Cambridge Ring; that concept allows a large number of units to be connected as nodes on a loop, each node controlling a particular system resource — printer, hard disc, VDU etc. — resources are shared in the total system via messages which circulate around the loop.
- Current opinion is that this architecture will provide an ideal base for a distributed system such as the not-so-futuristic electronic office.
- The Atom must, therefore, be a strong contender for inclusion on the short list of a wide range of buyers. □

# BYTE SHOP

# COMPUTERLAND

your specialist Computerstore.

Well-proven systems for the serious user. Our computer stores are staffed by business experts, backed by first class maintenance support. Call in for advice and a demonstration of our range of systems.

### Cromemco System Three

The Cromemco buyer is choosing well-proven design, reliability and expandability. Start with a single terminal and grow into a multi-user system as your requirements expand. Excellent Cromemco software includes COBOL, FORTRAN and RPG-II. Ask for a demonstration of the Cromemco hard-disk and talk over with us how your application can be programmed.



### North Star Horizon

The reliable and long-established commercial favourite. Ask about our BYTE SHOP- developed packages – Invoicing, Sales and Purchase Ledger, Incomplete Records, Cash-Flow Analysis, Stock Control, etc. And use your Horizon to type perfect letters – it is an excellent word-processor.

**Nottingham**  
92a Upper Parliament Street  
Nottingham NG1 6LF  
Tel. 0602 40576 Telex. 377389

**Manchester**  
11 Gateway House  
Piccadilly Station Approach  
Manchester  
Tel. 061-236 4737 Telex. 666168

**Birmingham**  
94-96 Hurst Street  
Birmingham B5 4TD  
Tel. 021-622 7149 Telex. 336186

**Glasgow**  
Magnet House  
Waterloo Street  
Glasgow Tel. 041-221 7409  
Telex. 779263

**BYTE SHOP**  
**COMPUTERLAND**

– your specialist Computerstore.

**London**  
48 Tottenham Court Road  
London W185 4TD  
Tel. 01-636 0647

• Circle No. 164

# The Micro Revolution

The wonderchip promises exciting things as it infiltrates the industrial world. There are huge technical problems in applying it, but they may be dwarfed by the political and economic problems it raises. In this extract from his book *The Micro Revolution*, Futura £1.50, Peter Laurie looks at the unpleasant implications.

IT IS easy enough, in a way, to forecast what technology can do for us, and not so hard to see in isolation what it will do to change our lives. What is really difficult is to see what stands in the way of that technology being used.

To put it bluntly, there are political problems. For instance, PTTs — Post, Telephone and Telegraph administrations — in most countries have monopolies over communication. It is often forgotten, so peaceful is the tenor of our lives, that this monopoly is one of the foundations of a government's political power.

Charles II established the British Post Office simply so that he could read his enemies' letters, and thus forestall conspiracies such as those which had cost his father his head.

Politics is no different today, and an essential part in any government's power is its ability to intercept its citizens' communications. That power is not used as much as some people think — in London, Paris or New York there are probably not more than 2,000 or 3,000 telephones being tapped at a time.

## Labour-intensive

In fact, telephone tapping — as opposed to recording for possible later playback — is a very labour-intensive business. It is necessary to have people listening to the lines who know the suspects and their lives and can make sense of their cryptic remarks. Yet it was no surprise when the students at Copenhagen University 10 years ago found a room full of tape recorders under their union building. It emerged, after agonised debate, that the Danish Post Office maintained seven such posts, with which they recorded all international telephone calls for NATO Intelligence. If it happens on that scale in little Denmark, can one believe it does not happen everywhere?

So security services must look on proposals for widespread broadband links with great suspicion. Even the ordinary flow of data will be very difficult to monitor, without vastly expensive artificial-intelligence installations which can sample and interpret data streams. When communications become electronic, all the normal indicators of political unrest will disappear into electronic form and may well become buried in the huge mass of trivial material which will flood the highways.

If there were not some kind of

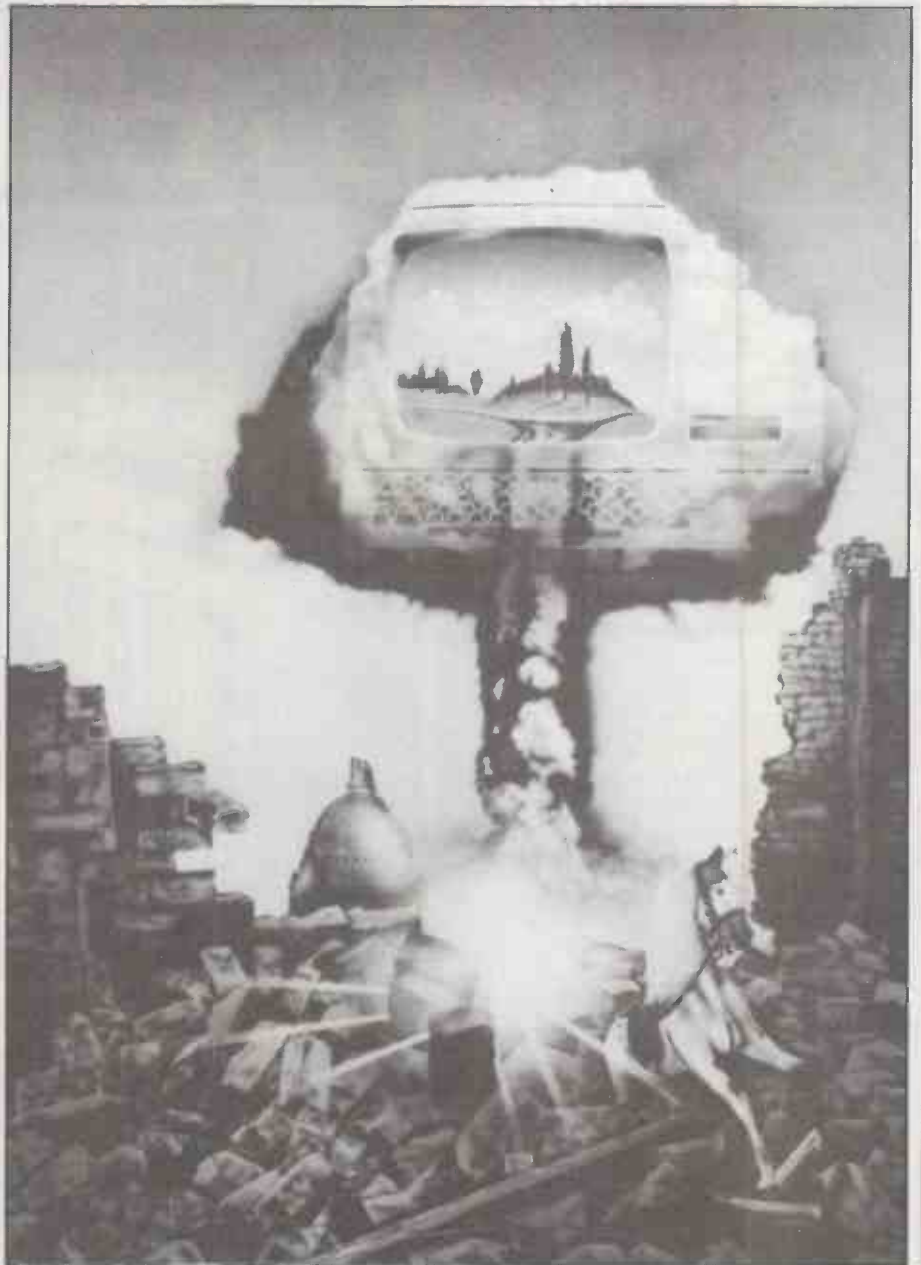

monitoring, one can see that it would be very easy to form large-scale conspiracies. With part of one's mind one scoffs but, on the other hand, would it be a good idea to let the National Front or the Ku Klux Klan go recruiting by video link? Should they show their publicity films in anybody's home? Ought one to allow them to organise encrypted conferences among their members, who may be spread anywhere in the country, unknown to their neighbours?

The first U.S. Ceefax system — in Salt

Lake City — has a time-slot option which makes pages accessible only if the time at which they are transmitted is set into the receiver as well as the page number. In effect, the time setting is a simple security code. The demonstration film issued by the Salt Lake City TV station concerned shows this page being used by the local Medical Association to transmit urgent news to doctors about an outbreak of food poisoning, but one can easily foresee more sinister uses.

I, for one, am not at all sure it would be

a good idea. So, for security's sake, there must be limitations on the right of free electronic communication — at least until people have got used to the new order. As James Martin pertinently observes in his book, *The Wired Society*, each major change in communications technology seems to have released the forces of revolution.

For instance, the revolutions and attempted revolutions that convulsed Europe in the middle of the last century coincided with the introduction of the telegraph — a device which reduced days of despatch riding to minutes of Morse-key clacking. Newspapers had information from the other side of the continent on the same day. So did revolutionaries. The simple stringing of wires had multiplied the pace of political life by a factor of about 100, and it is not surprising that the curbs which had worked well in the slow old days failed under the new circumstances.

The British history of civil defence records that the new invention of radio was a key weapon in the government's defeat of the General Strike in 1926. For the first time, the nation's leaders could talk, calmly, sensibly, intimately to the ordinary voter in his home. The impact was tremendous. Hitler and Stalin, in their time, both acknowledged that command of radio was a major factor in their political success.

Intense student unrest in the U.S. in the sixties was perhaps triggered by the widespread enjoyment of television. For the first time, civilians could see — almost bomb by bomb and bullet by bullet — how their army spent its defence budget. Hitherto, this disturbing knowledge had been the preserve of specialist war-correspondents.

## Direct contact

Direct contact with the military reality of a badly-run colonial war seems to have revolted a whole generation of young Americans, who very nearly made an end to their government. It is a testimony to the power of television that in all politically unstable countries it is the most strictly-censored medium of communication.

So, it would be foolish to expect that sudden access to great data highways will not have important political results, because politics is about co-ordinating the country's understanding and intelligence and it operates mainly in the sphere of communications. If techniques change suddenly, a whole new politics will have to be invented to cope. Since, as in technology, it is the newcomer who has the greatest incentive to master the new techniques, it is likely that, for a while anyway, the enemies of the existing order will make better use of it than the Establishment. Before things settle down, we may expect a few squalls.

On a more mundane plane, the installation of the new systems is going to

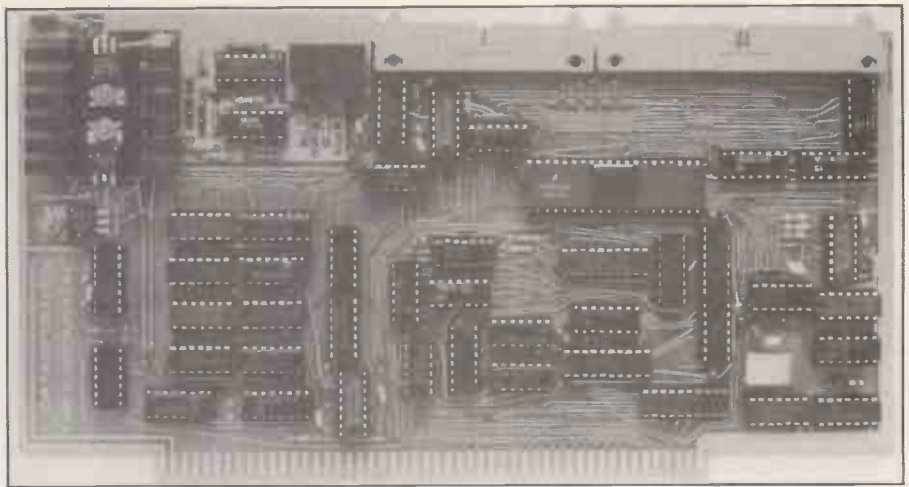

have an enormously upsetting economic effect on the old. For instance, today's audio switching network in the U.K. needs 250,000 engineers to maintain it. They are not highly-trained technicians. As the new systems arrive, few will be re-trained to cope with them. The technicians will not be in favour of a sudden switch which makes them useless.

Another problem is that natural copper ore deposits have almost been exhausted. Copper prices have risen and are rising sharply. What has happened is that the world's copper has been mined, refined, formed into wire and buried again under the cities of the West as telephone cable. The change to glass fibre or satellite radio will put millions of tons of pure copper on to the market. That will ruin countries like Zambia or Peru. Again, as a Post Office engineer told me sadly, the U.K., could have had electronic exchanges years ago if it were not that the entire city of Liverpool earns its living by building the antique mechanical sort, and seems incapable of learning to build the electronic version.

The Chief Constable of Liverpool is reported to have said recently that if the Post Office moved too fast with its electronic exchanges, he would have to introduce martial law to cope with the chaos that would result. These are not negligible problems. Technology is one thing; installing it is another matter — and perhaps just as well.

That leads to the bad news. The most obvious effect of the agricultural, *circa* 4,000 BC, and the industrial revolutions, *circa* AD 1760, was to begin rapid increases in populations. More hands meant more food which meant more hands.

The limited data-processing and distribution facilities afforded by scribes, clay tablets, horse couriers, national religions enforced a pyramidal structure on pre-electronic societies. The wider the base of peasants or factory workers, the higher the pyramid could rise and the more powerful it was in relation to other pyramids. There was consequently a driving tendency to increase populations up to the limit of the resources available,

and somewhat beyond — it was found that a little peripheral famine did wonders for discipline.

According to a recent study done for the Government Central Policy Review Staff — the Think Tank — the country will need only 10 percent of today's labour force to supply all its material needs by AD 2010. Professor Tom Stonier, of Bradford University, based this prediction published in the *Guardian*, November 14, 1978, not on the unpredictable rate of technical change, but on the rate in the past at which new technology has been accepted by industry and society.

## Electronic world

So the electronic world alters all that. A large population is no longer necessarily a powerful one. In fact, if it has many unproductive people in it, it may well be weaker than a sparser, better-organised society in which everyone plays a useful part. For the larger one has to waste resources supporting useless members.

When everyone — or very nearly everyone — worked at stupid machines, they could form themselves into sub-masses and make their wishes felt by striking. Because of the interlinked nature of industrial economies, a small number of determined strikers could cause a good deal of inconvenience. Consequently, all the industrial states developed either forms of democracy to remove the necessity for strong demonstrations of that kind, or heavily repressive machineries to prevent them.

However, electronics changes that, too. If you do not work, because electronics does your job more cheaply than you can, you cannot strike. Your vote, which was a precursor or symbolic exercise of your ability to cause hardship to the economic system by striking, becomes irrelevant. You are no longer necessary as a market for other people's products because the only point of selling to you was — in the eyes of the economic system — to make you labour to buy them.

The basis of today's industrial system was explicitly worked out 150 years ago. It

*(continued on next page)*

(continued from previous page)

was then debated whether industrial workers should be kept in their then state of serfdom or whether they should be allowed to share in the wealth which the produced. The first view seemed at first the more sensible, but as an early economist put it:

To make men industrious, to make them shake off the lethargy which is natural to them, they must be inspired with a taste for the luxuries and enjoyments of civilised life. When this is done, artificial wants will become equally clamorous with those that are strictly necessary and they will increase exactly as the means of gratifying them increases. Whenever a taste for comforts and conveniences has been generally diffused, the wants and desires of man become altogether unlimited. The gratification of one leads directly to the formation of another. In highly-civilised societies, new products and new modes of enjoyment are constantly presenting themselves as motives to exertion and as means of rewarding it. Perseverance is, in consequence, given to all the operations of industry; and idleness, and its attendant trains of evils, almost entirely disappear.

J R McCulloch, 'Political Economy', *Encyclopaedia Britannica*, 1816 Supplement.

That is the system which made the industrial nations rich, but now electronics is hacking out its foundations. Since our robot at £1 an hour can work as well as the human at £3, we no longer require the services of the human. The earning power which he and his mates represented is now concentrated in the far fewer people who build and organise the robots. As long as industry continues at the same volume, they do very well. That is why computer programmers cost £100 a day.

### Explosive collapse

My feeling is that a too rapid implementation of the electronic world will lead to an explosive collapse of the industrial economy, because it will make many workers unnecessary both as producers and consumers. Consequently, the people who made things for them will become unnecessary.

What happens then? Well, in theory, although the workers are not working, because they have been automated out of a job, the same amount of goods being produced, so they are better off: they do as well without having to work. Yet our system says that they cannot have the goods unless they work, since goods are distributed as a reward for work. So we have to change our economic system to reward existence rather than usefulness.

Secondly, the individual worker's political, economic and social rights were guaranteed by his ability to strike. If he were upset, he did not have to revolt; he could draw attention to his works by not

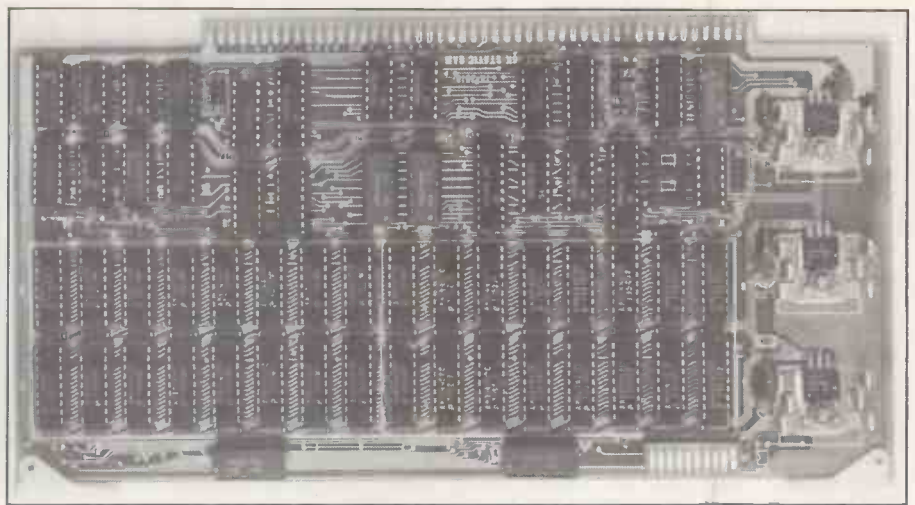

working. Now, he is not required to work and so cannot strike. Since his vote was simply a symbolic precursor of his right to strike, it now becomes meaningless. Deprived of industrial and political means of drawing attention to his grievances, the workers will be forced back on violence. So we have to alter our political system to make it sensitive to nuances of unease. Or we have to make it stronger to resist the workers of the industrial disenfranchised.

### Economic ills

I would argue that all this is happening now. It seems to me that the economic ills of the industrial nations are due exactly to this process. Because it is cheaper, for the moment anyway, to keep the unproductive within the system than to turn them out on the streets and have to defend oneself against them, all the industrial nations have this internal burden of an obsolete proletariat which has to seem to be treated as if it were productive.

From the realistic point of view, a worker is only worth paying £X a week if it costs more than £X a week to protect the system against him. He was to appear to be treated in line with the old ideas of equity and equality on a par with the really productive people whose earning capacity has been multiplied several times by the electronic revolution — limited as it is so far.

To put it simply: to begin with, one had an even continuum of workers from the lowest-paid lavatory cleaner to the highest-paid banker. Automation of one kind or another, rapidly rising in quantity and quality, imposes a threshold of ability below which a man is less useful than the machine.

For a while, it is simpler to keep the unemployables in the system, to make work for them, to use industry as a day prison.

As the number of unemployables grows, so the problems escalate. Because everyone has to be paid in accordance with the old steady graduation, the really productive people know very well that they are receiving nothing like their due. Because they can feel the whole system is

tottering towards collapse, the unproductive take advantage rights and leap to win what they can. Hence industrial unrest, many strikes, escalating pay claims, rapid inflation.

Inflation, which increases costs and earnings in relation to historic economic rights such as capital holdings, can be seen as the inevitable accompaniment of rapid change, discounting the past in favour of the future.

After a while, the burden of the unemployable will become too heavy to carry within the industrial system, and they will be dumped.

What accompanies that? A withdrawal of political and civil rights from the unemployed — of which the practical expression is rapidly-increasing wages for the productive, and rapidly-increasing costs for essential services. Thus, in the U.S., money can buy much better medicine, policing, and social services than are offered democratically to citizens at large.

The threatened proletariat quite clearly understands what is happening — see, for instance, the bitter unrest within the National Health Service over the issue of pay-beds in State hospitals. Crime and terrorism, the expressions of discontent and organisational protection for the haves against these threats.

### Not inevitable

Now, this image of a small, rich electronically productive A country within a large poor B one, having to defend its borders day and night against its hungry, miserable, despised neighbours, is not an attractive one. It is not the electronic millennium which we have been promised. But is it inevitable?

Happily not. The whole thing depends on birth, death and education. Men are born free and equal — parents, schools and jobs make us quite the opposite. We are, unfortunately, burdened with too many parents and with an educational system designed to produce large masses of docile, unimaginative industrial workers.

Even today, most jobs are part of a



game which decides who has what from heaps of wealth produced by the industrial system. Ten years ago, Schumacher, in *Small is Beautiful*, Sphere Books, London 1974, calculated that only three percent of human effort in the West was devoted to creating the necessities of life. The jobs everyone else did were only mechanisms for distributing necessities, and were irrelevant so far as supporting life went.

**Acute disproportion**

The electronic revolution will only make the disproportion between essential workers and the rest of us even more acute. Professor Stonier's 10 percent of useful workers will presumably include many whose function is strictly speaking unnecessary. The real core of necessary workers may fall to 0.3 percent or even 0.03 percent. However, it is not terribly important from this point of view just how many there are. What matters is that they are supporting and are surrounded by a vast majority of people in the B country, who can, if things are mishandled, be a deadly menace to them.

The size of the unwanted, underprivileged B country depends on two things: the rate at which its inhabitants can either be retrained as members of the A country or retired so they are out of the fray; and by the rate at which the A country expands. The first is more or less fixed by the realities of human intelligence and lifespan; so the recipe for avoiding disaster is to restrain the expansion of country A.

Seen from that point of view, the reluctance of trades unions to permit new technology — such as the closure of the *Times* and *Sunday Times* as a protest by the printing unions against electronics which would make them unnecessary — is a good thing. Better to have a little industrial strife along peaceful and well understood lines now, than the desperate waging of a last-ditch battle later on, when the workers have nothing left to sell but their lives.

The difficulty of this policy of allowing the twenty-first century to happen slowly and quietly is that the U.K. is in international competition with countries which have tougher social attitudes towards the unproductive, and can, therefore, afford to expand their A countries faster than we would like. The answer, perhaps, is to make sure that our contributions to the world's A economy are more valuable than those of our tough-minded competitors.

We can do this by selling them the means of becoming an A country; that is, the hardware and software needed to transform their industrial systems. So it seems to me that the recipe for survival is heavy investment in all kinds of electronic technology, and particularly its integration into social and industrial systems, along with a gentle attitude towards our own modernisation. If we fail, what then?

Suppose, for a moment, that by some magical art the difficulties of economics and politics could be bypassed and all the electronic devices, which are now tech-

nically possible, installed overnight. The result would be a sudden, drastic social change. Hundreds of millions of people would be without job, income *raison d'être*, self-respect, occupation, entertainment. One could expect very serious civil disturbances to break out no later than the end of next week.

**Essential resources**

Since all the nuclear powers would find themselves in the same situation, there is no doubt that a solution would soon suggest itself to their far-sighted leaders. They would argue that all the world's essential resources are dispersed in the countryside under civil defence planning; computers and records are underground in remote places; all the best minds are employed in research centres in the more remote and attractive parts of our countries.

The major cities, on the other hand, are full of an unemployed and unemployable rabble who promise at an early date to pull the twenty-first century down around our ears. It would not take many days' brooding of that kind before fingers at the end of wrists emerging from sky-blue uniform sleeves would edge towards red buttons. The USAF would deal with Omsk while the Soviet Rocket Corps took out Pittsburg; the RAF would tidy up Hamburg while France's *Force de Frappe* removed the menace of Birmingham.

For the sake of our skins and our children, we must tread very cautiously in this electronic affair.

# Gradual change will soften the technological blow

**A report prepared for the government of the Netherlands puts the ravages of the chip in a less lurid light.**

THE REPORT, commissioned by the Netherlands Ministry for Social Affairs from Metra Consulting Group is one of the soundest and most complete studies of the question yet published.

It consists of a general statement of the question, a summary of the evidence and conclusions, followed by extracts from specific documents which the authors studied drawn from the literature of Canada, France, Japan, Norway, Sweden, U.K., U.S.A. and West Germany.

**Everything pertinent**

More than 300 documents were covered and it is safe to say that anything pertinent has been considered by the authors. If they have missed something relevant, it is

because of mankind's ignorance rather than theirs.

In general, they found that very few studies did not even try to quantify the effects of the chip on the labour market: "Although the concept of job and skill effects the microelectronics is a straightforward one, the estimation of those effects is complicated by the fact that they take place against a background of other technological developments and economic and market factors.

"It was not possible to arrive at any conclusions about the effects of microelectronics on the overall level of employment, i.e., over all application areas. No studies were identified which attempted such an analysis, and most informed comment was that such a study would be very

difficult", maintains the Dutch chip report.

It is a simple document to understand, partly because it does not try to make pronouncements which are not supported by facts, or try to indulge in elaborate statistical fantasies in an attempt to find information which was not there in the first place. Certain numerical estimates are worth quoting:

**Numerical control**

It may be possible to automate 80 percent of jobs in banking.

Numerical control of machine tools in manufacturing, together with robots for moving and assembling parts might ultimately automate 25 to 80 percent of jobs, with the upper figure dependent on the in-

*(continued on next page)*

(continued from previous page)

stallation of integrated systems which automate a complete factory from order to delivery.

The installation of electronic devices in small machines like typewriters, cash registers, telephone exchanges should reduce the labour needed for their manufacture by 50 percent.

## Word processing

Word processing can double a typist's output — or halve the number of typists needed. Ultimately, it may be possible to automate 25 percent of office jobs. Prestel-like technology will have no foreseeable impact on the print industry.

The process industries will be hardly affected because their labour forces are so small already. Even in a fully-automated plant a manual crew would still be needed for emergencies.

In materials' handling, 25 percent of labour might be saved.

In many jobs the saving of labour allowed by chip technology will be more than offset by the increase in business brought about by being able to offer better services. Thus, the U.K. Post Office — 450,000 employees — expects that current staff levels will remain constant through the next 10 years.

## Decreased employment

Yet as the French Nora-Minc report warns, the introduction of automation will be led by the large companies which have capital to invest. That will lead to slight decreases in employment, so that the "only industrial jobs to be created in the future will be in small and medium-sized enterprises".

If the Metra Group report is not very precise, it is certainly reassuring. In assembling the sum of the western world's thought on the subject, it presents the

readers with the many difficulties there are in applying microelectronics and makes it clear how, in the words of the U.K. Cabinet's Think Tank report, the change is likely to be: "Evolutionary rather than revolutionary and the consequent employment effects are likely to be slow to show themselves and in most areas to offer reasonable opportunities for planned adjustment".

Even though the Metra group shows how difficult it is to make quantitative judgments, we thought it might be interesting to apply some estimates to the British economy to obtain an idea of the numbers likely to be involved. It should be emphasised that our figures are based only in the crudest way on the Metra findings, and would certainly not have its blessing.

## Selling proposition

The central selling proposition in the small business sector of microcomputing is that for the annual wage of a secretary — £4,000 — paid once you can buy a machine which will replace one person permanently. Suppose that the price falls to £1,000 with large volumes.

In practice, there are few jobs so stupid that a microcomputer can do them automatically. What ideally happens is that part of the work of several people is saved, and also made more efficient so that the business feels the benefit of a lump sum paid for the equipment every year until the machinery wears out or is replaced.

Still, for the sake of argument, let us say that one micro at £1,000 will replace one suitable job. How many suitable jobs are there? If we take as the roughest average of the figures assembled by Metra that 30 percent of jobs in suitable industries can be automated within the current technology horizon, and that those indus-

tries are — using the Government classifications — :

Description	Number employed Millions
Engineering	2.5
Textiles	2.2
Transport and communications	1.4
Distributive trades	2.7
Insurance and banking	1.1
Professional and scientific	3.6
Public administration and defence	1.6
Miscellaneous	2.4
30 percent of total	5.2

It seems clear that the crucial question is the speed with which this replacement takes place. On that depends the amount of social turmoil it creates.

Setting aside the questions of the availability of the software, the will of managers to introduce automation, the acquiescence of the unions in accepting the new situation — which are all very imponderable — we can make a few definite points.

## Natural wastage

Firstly, natural wastage will do much to soften the blow. Curiously, no-one seems to know just how long on average people spend in a job. The best the Department of Employment can offer is turnover in manufacturing industry, which seems to be about 20 per 100 per year, giving an average time in a job of five years. Since that is averaged for all jobs, one would expect the length of stay to be shorter at the lower grades affected by computing.

Secondly, if we reckon that the hardware needed to replace a person costs £1,000, the necessary investment needed to automate those jobs is £5,200 million. That is a large sum, even at current prices. The whole of British industry spends £11,000 million a year on investment in equipment and plant.

It would be unrealistic to expect more than, say, 10 percent at the outside to be spent on automation, so that it will take at least five years to invest the necessary capital, and probably more like 15 to 20.

Thirdly, it is most unlikely that so large an investment in equipment will be spent abroad. The £1,000 worth of machinery needed to replace a worker represents three months work by someone — since ultimately all costs are labour costs.

## Managable problems

Even if we imagine a new automating industry of 1,000,000 workers, it will take them at least two or three years to produce the necessary equipment, let alone the time needed to recruit, train and finance them.

So it is hard to see how, even if there were no social and technical problems at all, the chip could replace even one-third of workers in less than five to 15 years. Which really means that the problems it poses are quite managable.

Metra Consulting Group Ltd, 23 Lower Belgrave St, London SW1W 0NS 01-730 0855. 

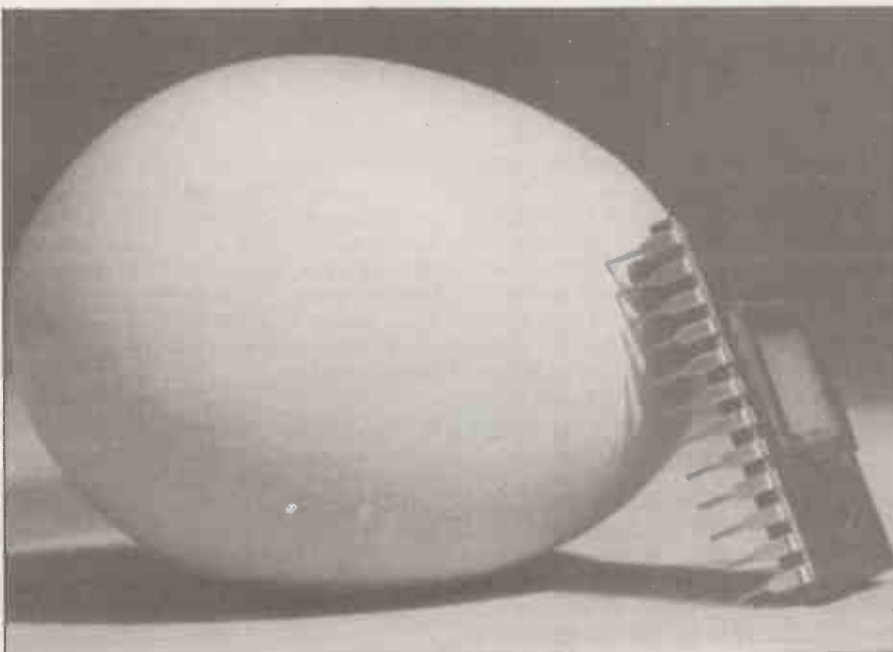

# SUPERBRAIN



**64K RAM CP/M™ 2.2**

**DISK CAPACITY**

**324K**

**£1450**

**676K**

**£1800**

**1.58MB**

**£2050**

**NATIONWIDE DISTRIBUTION**

**Delivery ex-stock**

**C.O.D.(NOT BEFORE)**

**FORMDOWN LTD.**

**79 Agincourt Road, London NW3 2NT.**

**Tel: 01-485 3186**

**CP/M™ is a registered trademark of Digital Research**

• Circle No. 165

# Modelling the world's future on your microcomputer

Imminent global collapse was predicted in the famous Club of Rome *Limits to Growth* report of 1972. Now, TP Mervyn offers World Simulation, his adaptation in Basic of the programs used by the Club to arrive at those conclusions.

IN THE early 1970s, a report produced by a group of scientists, educators, humanists, industrialists and national and international civil servants known collectively as the Club of Rome caused a good deal of controversy.

The Club's report, *Limits to Growth*, predicted global disaster unless steps were taken to reduce economic growth to a fraction of the current level. The predictions of the report were produced by computer runs of a mathematical model which attempted to stimulate the behaviour of the world treated as a mathematical model using a specialised modelling technique called system dynamics.

The computer model produced by Meadows and his associates at M I T was based on an earlier model produced by

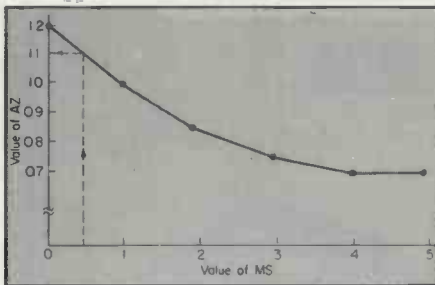

Figure 1.

system dynamics pioneer Jay W Forrester, Sloan Professor of Finance at M I T.

Forrester's earlier work was in the field of business and industrial systems and system dynamics was the formal technique devised originally for defining such systems. Any reader interested in system dynamics, rather than in its use for solving world systems, is strongly advised to consult *Principles of Systems* by Jay W Forrester.

For the not particularly technically-minded reader, here is a brief introduction to how systems dynamics is used with particular reference to Forrester's program the Basic version of which is presented.

First, various key parameters of the system, called levels are defined. They are set to known initial values which in the case of the world model described correspond to the levels at year 1900. The quantities are linked to each other in a series of loops.

Various other auxiliary quantities occur: in some cases, they occur within a

connection between level variables, in other cases, they might be found in a small feedback loop from a level to itself. In all cases, though, the results from the auxiliary quantities eventually become inputs to the level parameters.

Rate quantities are also calculated from inputs which depend on both the auxiliary quantities and the level values. These rate values are incremented over a short time period — in the world model, that is conventionally one-fifth of a year — and by use of a simple tangent line approximation new rates are determined.

## Auxiliary quantities

A mathematically-inclined reader will understand that the world model is a large chain of interacting differential equations and we are using only the crudest of numerical techniques to solve them.

Having calculated auxiliary quantities, levels and rates, we now repeat this process in an iterative fashion. The former levels, auxiliary quantities and rates are used to compute the new values and so on.

The model is now stepped through as many cycles as required. A simple calculation shows for a world model covering years 1900 to 2100, we require 1,000 such iterations.

It is possible to describe the world system modelled by a system dynamics flowchart. That is a modification of the flowchart normally used in a program. Special symbols are used to denote levels, auxiliary quantities, etc

The system dynamics model is independent of any particular computer language and could presumably be solved using most high-level scientific/mathematical languages. However, Forrester chose to solve the problem using a programming language specially developed for solving problems in system dynamics.

It is the Dynamo language DYNAMIC MODelling. Dynamo is especially useful as it allows each level quantity, auxiliary, rate and initialisation to be defined in a single program statement. Here are a few statements in Dynamo to give the flavour of the language.

4.1	C	SWT3 = 1970
Line number	shows a	Constant SWT3 is
	Constant is	set to 1970
	being defined	
37.2	R GUNK.KL =	(CIRFT)
	(P.K)	

Line number	Rate	Multiplication by
	equation	CIRFT
	Rate GUNK The	is implied
	.KL denotes a	
	new rate;	
	the previous value	
	of the rate is	
	GUNK.JK	

Although Forrester's original model of the world system must have taken him many months or even years to develop, its computer implementation is a reasonably simple matter. My program, which is a Basic version of Forrester's original Dynamo program, runs easily within the memory capacity of a 16K Level II TRS-80.

The listing of the program is shown in figure 4. A description of all the variables and quantities used in the program is provided within the key.

## Population level

PL — the population level. The population is initialised at time 1900 to a value of 1.65 U.S. billion. The principal factor which determines the new population level is naturally the difference between the birth-rate and the death-rate. Anyone tracing through the equations of the system — see lines 4060 and 4130 — will notice that both those rate quantities are

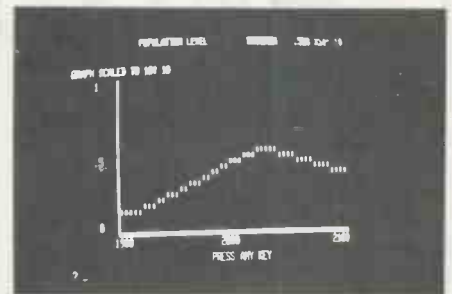

Figure 2.

given by the product of six other quantities.

One quantity is obviously the current population level and quantity CP. The remaining four quantities are auxiliary quantities. Those four quantities affect the birth rate:

- AZ — the birth-rate multiplier from material standards. It is a function of the material standard of life A more detailed explanation of how AZ is calculated is given in table look-ups and interpolation.
- GZ — the birth-rate multiplier from crowding — is one of the functions

- of the crowding-ratio multiplier.
- HZ — the birth-rate multiplier from food — a function of the food-ratio multiplier.
- IZ — the birth-rate multiplier from pollution — a function of the pollution-ratio multiplier.

CP is a clip quantity and line 4050 allows it to take different values depending on the time value, TI. Thus, the birth-rate can be changed to a fraction of its initial value by making B1 a fraction of B.

That will happen at the time we allocate to S1 which is called a switch time. In the standard run program, all clip functions have the same value before and after the switch times, and all switch values are set to 1970 as befits a model published at around this date. Clip functions and

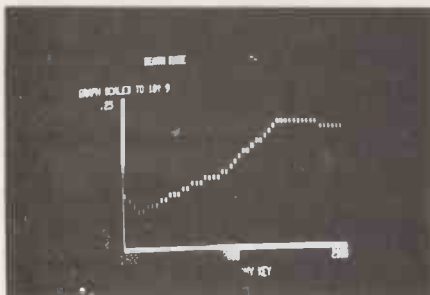

Figure 3.

switch times can be used to produce a different set of results from the program.

Without going into detail, anyone diligent may well be able to trace the connections from the program listing together with the annotations provided in the key. The other main level variables are:

- CL — capital investment level
- AF — fraction of capital invested in agriculture
- YL — pollution level
- NR — natural resources level

In the model, 22 important auxiliary quantities occur which are looked-up in a set of tables. A routine provides linear interpolation to obtain the auxiliary quantity which is being found. Let us see how this works by referring to just one example. This is AZ, which as we saw previously is the birth-rate multiplier from material standards.

## Data array values

The table which is used to find AZ is contained within the array AT — line 1000. The data values for the array are found in line 630. The array AT contains set values for BRMNT — in Forrester's notation — which is the birth-rate from material multiplier table.

The values contained within AT depend on the value of another quantity, the material standard of life — MS. The graphical form of this relationship is shown in the graph — figure 3.

Notice that points on the graph are assumed to be connected by straight line segments. Thus, when we interpolate the

graph we use linear interpolation. To examine how AZ is found, let us assume that MS has a current value of 0.5. The table look-up routine for AZ notes that the value of AZ depends on MS. Note that MS will range from zero to five in steps of one unit. This is why line 2100 is included.

If you look at figure 1, you see a value of MS=0.5 is interpolated to give an AZ value of 1.1. You can check that the sequence from 2100 to 2140 via sub-routines at 5000 and 6000 does actually return this value.

After entering and copying the program, you should ensure that you have another clean good-quality cassette. The program generates a large amount of data which must be dumped on to tape. You should use at least a C20 tape for this as about seven or eight minutes' worth of results are collected.

Set your tape recorder to the normal level you use for recording programs. The results are output on to the screen of your VDU at the same time as they are dumped on to tape. On my system, it takes four minutes from one set of results to be output to the next set. That corresponds to a time period of four years. Thus the complete program takes about three hours 20 minutes.

Obviously, with that amount of time involved you have to treat the program as part of a batch run. For that obvious reason, I have included no interactive components to the program. After the run is complete and the last result — for year 2100 — is displayed on the screen, you may re-wind the tape containing the results. Now enter, or re-load the plotter program. — figure 5.

## Plotter program

The results from the main program are fed into the plotter program by setting the cassette recorder to play — obviously not to record. As the results for each four-year period are input by the plotter program the results are flashed on the screen.

After all the results have been input, the plotter program presents you with a menu and you may plot any one of 16 quantities including all the level variables and most of the main auxiliary quantities.

Some results are displayed in figures 2 and 3, which are photographs of the results plotted on the VDU. The plotter program allows all those variables to be plotted as many times as required.

The system I used, with TRS-80 graphics, is obviously not terribly detailed; those with high-resolution and/or colour graphics should be able to obtain some striking results by simple modifications to the plotter program.

Those with printers may like to consider devising a routine which will allow them printed output instead of the output to monitor described.

## Key and Annotations

**Constants** Forrester's names for the constants, etc., are given in parentheses.

P	Population initial (PI)
B	Birth-rate normal (BRN)
B1	Birth-rate normal number 1 (BRN1)
S1	Switch time 1 (SWT1)
E	Effective capital investment ratio normal (ECIRN)
N1	Natural resources initial (NR1)
N2	Natural resource usage normal (NRUN)
N3	Natural resource usage normal number 1 (NRUN1)
S2	Switch time 2 (SWT2)
D	Death-rate normal (DRN)
D1	Death-rate normal number 1 (DRN1)
L	Land area (LA)
PI	Population density normal (PDN)
F	Food coefficient (FC)
F1	Food coefficient number 1 (FC1)
F2	Food normal (FN)
S7	Switch time 7 (SWT7)
C	Capital investment in agriculture fraction normal (CIAFN)
C1	Capital investment initial (CI)
C2	Capital investment generation normal (CIGN)
C3	Capital investment generation normal number 1 (CIGN1)
S4	Switch time 4 (SWT4)
C4	Capital investment discard normal (CIDN)
C5	Capital investment discard normal number 1 (CIDN1)
S5	Switch time 5 (SWT5)
P2	Pollution standard (POLS)
P3	Pollution initial (POLI)
P4	Pollution normal (POLN)
P5	Pollution normal number 1 (POLN1)
S6	Switch time 6
C6	Capital investment in agriculture fraction initial (CIAFI)
C7	Capital investment in agriculture fraction adjustment time (CIAFT)
Q	Quality of life standard (QLS)
DI	Time increment (DT)
L1	Upper time limit (LENGTH)
P6	Print period number 1 (PRTP1)
P7	Print period number 2 (PRTP2)
P8	Print switch time (PRSWT)
P9	Plot period number 1 (PLTP1)
P0	Plot period number 2 (PLTP2)
PW	Plot switch time (PLSWT)
SS	Loop start time (no equivalent)
TF	Loop finish time (no equivalent)

The main program is written in a limited subset of Microsoft Basic. The only non-standard lines would seem to be those which use CLS — the TRS-80 clear-screen instruction — and those lines, 7100 and 8210, which use TRS-80 output to tape recorder. No-one should have problems finding the equivalents to those in his system's dialect.

The plotter program which uses the TRS-80 SET (X,Y) instruction will need more modifications, particularly with Pet computers where an equivalent instruction is not available.

The plotter program which uses the TRS-80 set (X,Y) instruction will need more modifications, particularly with Pet computers where an equivalent instruction is not available.

(continued on page 79)

# Buying Computers?

Commodore PET 32K  
£675.75 plus VAT

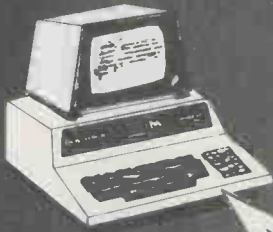

Sharp MZ-80K  
£480.00 plus VAT



ITT 20/20 16K  
£607.00 plus VAT



ACT 808 inc dual  
disk drive  
£3950.00 plus VAT

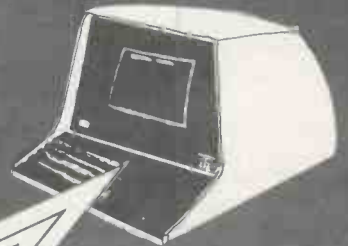

ACT 808 inc dual  
disk drive  
£3950.00  
plus VAT

## We'll give you more than a good deal

**Under one roof in London's West End you can find:**

**HARDWARE:**

A comprehensive range of hardware to meet most applications – and budgets, with terms to suit you.

**SOFTWARE:**

Probably the widest range of off-the-shelf software in the UK. Try out the packages and choose the one that suits you, or take advantage of our consultancy services and we will analyse, recommend, demonstrate, modify and install the programs for you.

**CONSULTANCY SERVICES:**

To apply micro computer systems to business, education or the home, make an appointment with our trained professionals for friendly advice based on extensive experience of discussing problems with many others like you.

**MAINTENANCE AND REPAIR CLUB:**

A maintenance and repair club that guarantees microcomputer users minimum downtime at very attractive premiums.

**REFERENCE MATERIAL:**

A library of publications covering all aspects of the microcomputer world,

including back issues of this and other important periodicals.

Whether you are an experienced micro user or a novice, looking for a system for the home, business or pleasure, the **LION MICROCOMPUTER CENTRE** is the single source to meet all your requirements.

**CALL IN ANY TIME.** We are open six days a week, for you to take advantage of the good deal you get when you buy from **LION**.

The above prices do not apply to account sales.



## LION MICRO-COMPUTERS

SMALL COMPUTERS—TO MAKE YOUR BUSINESS BIGGER  
Lion Computer Shops Ltd, Lion House, 227 Tottenham Court Road,  
London W1 (First Floor). Telephone: 01-637 1601.  
Telex: 28394 Lion G.  
Open 9 to 6, Monday to Saturday (Thursday to 7).



(continued from page 77)

For anybody wishing to save time and wear on fingers when entering the program, all REMs up to, but not including, line 8000 may be deleted; all initialisations may be set numerically at the start of the program; but some work will be required to tabulate those initial values.

If you do this properly, subroutines from line 9000 onwards will not be

### Other auxiliary quantities and rates

BR	Birth-rate (BR)
DR	Death-rate (DR)
CR	Crowding ratio (CR)
CK	Capital investment ratio (CIR)
CA	Capital investment ratio in agriculture (CIRA)
NF	Natural resource fraction remaining (NRFR)
EC	Effective capital investment ratio (ECIR)
MS	Material standard of living (MSL)
FR	Food ratio (FR)
NU	Natural resource usage rate (NRUR)
CD	Capital investment discard (CID)
CG	Capital investment generation (CIG)
PG	Pollution general (POLG)
PA	Pollution absorption (POLA)
YR	Pollution rate
QL	Quality of life (QL)

### Levels

PL	Population level (P)
CL	Capital investment level (CI)
AF	Capital investment in agriculture fraction level (CIAF)
YL	Pollution level (POL)
NR	Natural resources level (NR)

Figure 4.

required, neither will lines 1720 to 1900. You must however ensure that all the required initialisations have been adequately calculated by hand.

Variations on the standard run are:

●Pollution mode. In the standard run, the world population is reduced due to the shortfall in natural resources. In the pollution mode, we set N3 to .25. The effect of this is to reduce the rate of natural resource usage to 25 percent of its 1970 value. That leads ultimately to a drastic population crash at around year 2030 due to a crisis caused by pollution.

●Capital investment generation increase. In this model, we change C3 — the coefficient for normal capital investment generation — to 0.06, a 20 percent increase. Capital, therefore, accumulates to a 20 percent greater rate than the

original model. This results in a pollution crisis, similar to that in pollution mode.

●Birth control. Reduce B1 to 0.028. That causes a decrease in the birth-rate at 1970, but as you should see produces little change in the results of the standard run. Obviously, there is an almost infinite number of variations you can devise, each of which will produce some modification to the results of the standard model. Obviously, those interested in this model will need to refer to *World Dynamics* to try all the major variations suggested there. However, the more cynical may like to try the following change which was suggested, at least in part, by Forrester himself:

●Changing death-rate material multiplier table. Change the values in CT, line 650, to 2, 1.4, 1, .9, .85, .8, .77, .75, .75, 0, 0. As Forrester admits, page 40, the effect of the multiplier may have been exaggerated in his model. Gribbin in *Future Worlds* points out that if this assumption, i.e., the change of values, is built into the model, we can obtain a more optimistic model of the future. True, there is a decline of population in the 21st century, but this is due to a decline in birth-rate rather than an increase in death-rate.

As a teacher of computer studies, I have found that some children believe in the model without reservation. If you also believe it, you may feel as certain groups did in the early 1970s, that we should now take steps to reduce economic growth before the doom-laden prognostications of the model are borne out by fact, some time in the next century.

Yet changes in the model, some of them of a minor nature, produce completely different conclusions. The model, and the successor model used in *Limits to Growth*, make gross and probably unjustified assumptions about the world system. Their model is an aggregate model; the parameters of the richer and poorer nations of the world are clumped together to give an average result. The results of the Science Policy Research Unit at Sussex University have revealed limitations in the model; the results of their researchers are ably summarised by Gribbin.

My principal reason for producing the Basic programs was just to show that large and, in their time, very important simulation programs can be reproduced on a microcomputer.

### Table look-ups

The array names only are given; for array dimensions refer to the program

AT	Birth-rate from material multiplier table (BRMMT)
BT	Natural resource extraction multiplier table (NREMT)
CT	Death-rate material multiplier table (DRMMT)
DT	Death-rate from pollution multiplier table (DRPMT)
ET	Death-rate from food multiplier table (DRFMT)
FT	Death-rate from crowding multiplier table (DRCMT)
GT	Birth-rate from crowding multiplier table (BRCMT)
HT	Birth-rate from food multiplier table (BRFMT)
IT	Birth-rate from pollution multiplier table (BRPMT)
JT	Food from crowding multiplier table (FCMT)
KT	Food potential from capital investment table (FPCIT)
LT	Capital investment multiplier table (CIMT)
MT	Food from pollution multiplier table (FPMT)
NT	Pollution from capital multiplier table (POLCMT)
OT	Pollution absorption time table (POLATT)
PT	Capital fraction indicated by food ratio table (CFIFRT)
QT	Quality of life from material table (QLMT)
RT	Quality of life from crowding table (QLCT)
ST	Quality of life from food table (QLFT)
TT	Quality of life from pollution table (QLPT)
UT	Natural resource from material multiplier table (NRMMT)
VT	Capital investment from quality ratio table (CIQRT)

### Auxiliaries from tables

e.g. CZ is the auxiliary from table CT, FZ is the auxiliary from table FT, etc. The auxiliary has the same name as the table it was derived from, except, of course, the word 'table' is omitted. Thus, KZ is the food potential from capital investment.

### References

- The Limits to Growth*, Meadows et al., Pan Books 1972
- World Dynamics second edition*, Jay W Forrester, Wright-Allen Press 1973
- Principles of Systems*, Jay W Forrester, Wright-Allen
- Future Worlds*, John Gribbin, Abacus Press, 1979.

```

1 CLS
10 REM *****
20 REM * WORLD SIMULATION (ORIGINAL BY JAY W. FORRESTER) *
30 REM * A BASIC VERSION FOR THE TRS-80 *
40 REM * BY T. P. MERVYN FEB 1980 *
50 REM *
60 REM * FOR COMPLETE REFERENCE OF THE PROGRAM TEXT SEE *
70 REM * 'WORLD DYNAMICS' BY JAY W. FORRESTER *
80 REM * WRIGHT-ALLEN PRESS INC., 1971 *
90 REM *****
100 REM
110 REM INPUT CONSTANTS
120 REM
130 READ P,B,B1,B1E,N1,N2,N3,S2,D,D1,B3,I1,P1,F,F1,F2,S7,C,C1,C2,C3
140 READ SA,CA,C5,S5,P2,P3,PA,PS,SE,DE,C7,B,I1,I1,PS,P7,P8,P9,P8,P4,SS,TF
150 DATA 1.55E+9,.84,.84,1970,1.9E+11,1,1,1970,.028,.028,1970
160 DATA 1.35E+8,26.5,1,1,1,1970,.3,4E+9,.85,.85,1970,.025,.025
170 DATA 1970,3.6E+9,.2E+9,1,1,1970,.2,15,1,.2,2100,0,0,0,4,0
180 DATA 1900,2100
500 REM *****
510 REM * DIMENSIONS OF LOOK-UP TABLES *
520 REM
530 DIM AT(8),BT(7),CT(13),DT(9),ET(11),FT(8),BT(8)
540 DIM HT(7),IT(9),JT(8),KT(9),LT(8),MT(9),NT(8)
550 DIM OT(9),PT(7),QT(8),RT(13),BT(7),TT(9),UT(13)
560 DIM VT(7)
600 REM *****
610 REM * DATA VALUES FOR LOOK-UP TABLES *
620 REM *****
630 DATA 1,2,11,.85,.75,.7,7,0,0
640 DATA 0,.15,.5,.85,1,0,0
650 DATA 3,1,8,1,8,7,6,.53,.5,.5,.5,0,0
660 DATA .92,1,3,2,3,2,4,8,6,8,9,2,0,0
670 DATA 30,3,2,1,4,1,7,6,.5,5,0,0,0
680 DATA ,9,1,1,2,1,5,1,9,3,0,0
690 DATA 1,05,1,9,7,6,55,0,0
700 DATA 0,1,1,5,1,9,2,0,0
710 DATA 1,02,9,7,4,25,15,1,0,0
720 DATA 2,4,1,1,6,4,3,2,0,0
730 DATA .5,1,1,4,1,7,1,9,2,05,2,0,0
740 DATA .1,1,1,8,2,4,2,8,3,0,0
750 DATA 1,02,9,65,35,2,1,05,0,0
760 DATA .05,1,3,5,4,7,4,8,0,0
770 DATA .6,2,5,5,8,11,5,15,5,20,0,0

```

(continued on page 81)



**L.P. Enterprises,**  
Room PC  
11 Cambridge House  
Cambridge Road  
Barking, Essex IG11 8NT  
01-591 6511

**EUROPE'S LARGEST SELECTION OF MICROCOMPUTER BOOKS, MAGAZINES AND SOFTWARE FOR  
THE HOBBYIST, EDUCATIONALIST, PROFESSIONAL AND RETAILER**

#### FOR THE NOVICE

From the Counter to the Bottom Line	£10.00
Your Home Computer	£ 5.95
Introduction to Personal and Business Computing	£ 4.95
Getting Involved with Your Own Computer	£ 4.75
How to Profit from Your Personal Computer	£ 5.50
Microcomputer Potpourri	£ 2.40
Hobby Computers are Here	£ 3.95
New Hobby Computers	£ 3.95
Understanding Microcomputers and Small Computer Systems	£ 6.75
Understanding Microcomputers and Small Computer Systems and Audio Cassette	£ 8.75

#### FOR FUN

SARGON — A Chess Game	£ 9.50
BASIC Computer Games	£ 5.00
More BASIC Computer Games	£ 5.50
What to do After you Hit Return	£ 8.95
8080 Galaxy Game	£ 6.95
SUPER — WUMPUS — A game in 6800 Assembler Code & BASIC	£ 4.25
Computer Music Book	£ 6.75
Computer Rage (A board game)	£ 6.95
Artist and Computer	£ 3.95
Games, Tricks and Puzzles for a Hand Calculator	£ 2.49
Introduction to TRS-80 Graphics	£ 5.75
Take My Computer Please... (Fiction)	£ 3.25
Introduction to Low Resolution Graphics	£ 5.50

#### CONCERNING LANGUAGE

SCALBAL — High Level Language Plus Supplements	£15.00
Instant BASIC	£ 6.95
Basic BASIC	£ 6.50
Advanced BASIC	£ 6.00
Users Guide to North Star BASIC	£10.00
A Practical Introduction to PASCAL	£ 3.95
Microsoft BASIC	£ 6.50

#### FOR THE 6502

32 BASIC Programs for the PET	£10.00
6502 Software Gourmet Guide & Cookbook	£ 7.15
Best of Micro, Vol 1	£ 5.50
Best of Micro, Vol 2	£ 5.50
Programming the 6502 (Zans)	£ 7.95
Programming the 6502 (Foster)	£ 6.75
6502 Applications	£ 7.95
6502 Assembly Language Programming	£ 8.25
The PET and the IEEE 488 (GPIB) bus	£ 9.95

#### GENERAL

*See Magazines and Subscriptions! See Osborne Books!*

Microprocessors from Chips to Systems	£ 7.00
Microprocessor Interfacing Techniques	£ 8.75
Numbers, in Theory and Practice	£ 5.95
Cheap Video Cookbook	£ 4.30
CMOS Cookbook	£ 7.50
IC OP-AMP Cookbook	£ 8.95
RTL Cookbook	£ 4.25
TTL Cookbook	£ 7.50
Ciarcias Circuit Cellar	£ 5.50
First Book of Kim	£ 7.00
Buyers Guide to Microsoftware	£ 2.40
Calculating with BASIC	£ 4.95
Computer Programs that Work (In BASIC)	£ 2.95
BASIC Software Library: (Listings)	
Vol 2: Maths, Engineering and Statistical Programs	£17.50
Vol 3: Advanced Business Programs	£26.95
Vol 5: Experimenters Programs	£ 7.95
Vol 6: Miniature Business System	£32.50
Vol 7: Chess/Medbil/Wdproc. Programs	£26.95
Vol 8: Homeowners Programs	£14.05
Best of Interface Age: Software	£ 9.95
Bar Code Loader for 6800, 8080, Z80 and 6502	£ 1.75
Best of BYTE	£ 8.95
Scelbi BYTE Primer	£ 8.95
Best of Creative Computing, Vol 1	£ 6.95
Best of Creative Computing, Vol 2	£ 6.95
Program Design	£ 4.25
Programming Techniques: Simulation	£ 4.25
PIMS — A Database Management System	£ 5.95

#### HOW TO PURCHASE

Send cash, cheque, PO or credit card no. to L.P. Enterprises, Room PC, 11 Cambridge House, Cambridge Road, Barking, Essex IG11 8NT. 01-591 6511. All payment must be in sterling and drawn against a UK bank.

The titles specified here are but a small selection of our range. For the complete list, send an SAE to the above address, or come and visit our showroom (open during office hours).



(continued from page 79)

```

780 DATA 1, 6, 3, 15, 1, 0, 0
790 DATA 2, 1, 1, 7, 2, 3, 2, 7, 2, 9, 0, 0
800 DATA 2, 1, 3, 1, 75, 55, 45, 38, 3, 25, 22, 2, 0, 0
810 DATA 0, 1, 1, 8, 2, 4, 2, 7, 0, 0
820 DATA 1, 04, 1, 85, 1, 6, 3, 15, 1, 05, 1, 02, 0, 0
830 DATA 0, 1, 1, 8, 2, 4, 2, 9, 3, 3, 6, 3, 8, 3, 9, 3, 95, 0, 0, 0
840 DATA 7, 8, 1, 1, 5, 2, 0, 0
970 REM *****
980 REM * INPUT TABLE LOOK-UPS *
990 REM *****
1000 FOR I=1 TO 8: READ AT(I): NEXT
1010 FOR I=1 TO 7: READ BT(I): NEXT
1020 FOR I=1 TO 13: READ CT(I): NEXT
1030 FOR I=1 TO 9: READ DT(I): NEXT
1040 FOR I=1 TO 11: READ ET(I): NEXT
1050 FOR I=1 TO 9: READ FT(I): NEXT
1060 FOR I=1 TO 8: READ GT(I): NEXT
1070 FOR I=1 TO 7: READ HT(I): NEXT
1080 FOR I=1 TO 9: READ IT(I): NEXT
1090 FOR I=1 TO 8: READ JT(I): NEXT
1100 FOR I=1 TO 9: READ KT(I): NEXT
1110 FOR I=1 TO 8: READ LT(I): NEXT
1120 FOR I=1 TO 9: READ MT(I): NEXT
1130 FOR I=1 TO 9: READ NT(I): NEXT
1140 FOR I=1 TO 9: READ OT(I): NEXT
1150 FOR I=1 TO 7: READ PT(I): NEXT
1160 FOR I=1 TO 9: READ QT(I): NEXT
1170 FOR I=1 TO 13: READ RT(I): NEXT
1180 FOR I=1 TO 7: READ ST(I): NEXT
1190 FOR I=1 TO 9: READ TT(I): NEXT
1200 FOR I=1 TO 13: READ UT(I): NEXT
1210 FOR I=1 TO 7: READ VT(I): NEXT
1400 REM *****
1490 REM * INITIALISE LEVEL VARIABLES *
1500 REM *****
1510 PL=P
1520 NL=N1
1530 CL=C1
1540 YL=P3
1550 AF=C6
1570 REM *****
1580 REM * OTHER INITIALISATIONS *
1590 REM *****
1600 REM *****
1610 CR=PL/(L*P1)
1620 CK=CL/PL
1630 CA=(CK*AF)/L
1640 NF=(NL/N1)
1650 EC=(CK*(1-AF))/(1-C)
1660 MS=EC/E
1720 REM *****
1730 REM * FOOD RATIO LOOK UP *
1740 REM *****
1750 DV=CA: I=0: J=5: K=1
1760 GOSUB 5000
1770 JJ=KT(IV): KK=KT(IV+1): LI=KT(1): MM=KT(7)
1780 GOSUB 6000
1790 KZ=RV
1800 DV=CR: I=0: J=5: K=1
1810 GOSUB 5000
1820 JJ=JT(IV): KK=JT(IV+1): LI=JT(1): MM=JT(6)
1830 GOSUB 6000
1840 JZ=RV
1850 DV=YR: I=0: J=60: K=10
1860 GOSUB 5000
1870 JJ=MT(IV): KK=MT(IV+1): LI=MT(1): MM=MT(7)
1880 GOSUB 5000
1890 MZ=RV
1900 FR=(KZ+JZ+MZ)/F2
1910 GOSUB 9000 'GET INITIAL QUANTITY OF LIFE
1920 GOSUB 10000 'GET INITIAL RESOURCES USAGE RATE
1930 GOSUB 11000 'GET INITIAL BIRTH-DEATH
1940 GOSUB 12000 'GET INITIAL WEATHER
1950 GOSUB 7000 'INITIAL I/P ROUTINE
1980 REM *****
1990 REM * TABLE LOOK UP SEQUENCE *
2000 REM *****
2030 REM *****
2050 REM *****
2060 REM * GET TIME LOOPS GOING *
2070 REM *****
2080 FOR TI=85 TO (TF-4) STEP 4
2090 FOR YB=1 TO 20
2100 DV=MS: I=0: J=5: K=1
2110 GOSUB 5000
2120 JJ=QT(IV): KK=QT(IV+1): LI=QT(1): MM=QT(6)
2130 GOSUB 6000
2140 AZ=RV
2150 DV=NF: I=0: J=1: K=.25
2160 GOSUB 5000
2170 JJ=BT(IV): KK=BT(IV+1): LI=BT(1): MM=BT(5)
2180 GOSUB 6000
2190 BZ=RV
2200 DV=MS: I=0: J=5: K=.5
2210 GOSUB 5000
2220 JJ=CT(IV): KK=CT(IV+1): LI=CT(1): MM=CT(3)
2230 GOSUB 6000
2240 CZ=RV
2250 DV=YR: I=0: J=60: K=10
2260 GOSUB 5000
2270 JJ=DT(IV): KK=DT(IV+1): LI=DT(1): MM=DT(7)
2280 GOSUB 6000
2290 DZ=RV
2300 DV=FR: I=0: J=2: K=.25
2310 GOSUB 5000
2320 JJ=ET(IV): KK=ET(IV+1): LI=ET(1): MM=ET(9)
2330 GOSUB 6000
2340 EZ=RV
2350 DV=CR: I=0: J=5: K=1
2360 GOSUB 5000
2370 JJ=FT(IV): KK=FT(IV+1): LI=FT(1): MM=FT(5)
2380 GOSUB 5000
2390 FZ=RV
2400 DV=CR: I=0: J=5: K=1
2410 GOSUB 5000
2420 JJ=GT(IV): KK=GT(IV+1): LI=GT(1): MM=GT(6)
2430 GOSUB 6000
2440 GZ=RV
2450 DV=FR: I=0: J=4: K=1
2460 GOSUB 5000
2470 JJ=HT(IV): KK=HT(IV+1): LI=HT(1): MM=HT(5)
2480 GOSUB 6000
2490 HZ=RV
2500 DV=YR: I=0: J=60: K=10
2510 GOSUB 5000
2520 JJ=IT(IV): KK=IT(IV+1): LI=IT(1): MM=IT(7)
2530 GOSUB 6000
2540 IZ=RV
2550 DV=CR: I=0: J=5: K=1
2560 GOSUB 5000
2570 JJ=JT(IV): KK=JT(IV+1): LI=JT(1): MM=JT(6)
2580 GOSUB 6000
2590 JZ=RV
2600 DV=CR: I=0: J=6: K=1
2610 GOSUB 5000
2620 JJ=KT(IV): KK=KT(IV+1): LI=KT(1): MM=KT(7)
2630 GOSUB 6000
2640 KZ=RV
2650 DV=MS: I=0: J=5: K=1
2660 GOSUB 5000
2670 JJ=LT(IV): KK=LT(IV+1): LI=LT(1): MM=LT(6)
2680 GOSUB 6000
2690 LZ=RV
2700 DV=YR: I=0: J=60: K=10
2710 GOSUB 5000
2720 JJ=MT(IV): KK=MT(IV+1): LI=MT(1): MM=MT(7)
2730 GOSUB 6000
2740 MZ=RV
2750 DV=CR: I=0: J=5: K=1
2760 GOSUB 5000
2770 JJ=NT(IV): KK=NT(IV+1): LI=NT(1): MM=NT(6)
2780 GOSUB 6000
2790 NZ=RV
2800 DV=YR: I=0: J=60: K=10
2810 GOSUB 5000
2820 JJ=OT(IV): KK=OT(IV+1): LI=OT(1): MM=OT(7)
2830 GOSUB 6000
2840 OZ=RV
2850 DV=FR: I=0: J=2: K=.5
2860 GOSUB 5000
2870 JJ=PT(IV): KK=PT(IV+1): LI=PT(1): MM=PT(5)
2880 GOSUB 6000
2890 PZ=RV
2900 DV=MS: I=0: J=5: K=1
2910 GOSUB 5000
2920 JJ=QT(IV): KK=QT(IV+1): LI=QT(1): MM=QT(6)
2930 GOSUB 6000
2940 QZ=RV
2950 DV=CR: I=0: J=5: K=.5
2960 GOSUB 5000
2970 JJ=RT(IV): KK=RT(IV+1): LI=RT(1): MM=RT(11)
2980 GOSUB 6000
2990 RZ=RV
3000 DV=FR: I=0: J=4: K=1
3010 GOSUB 5000
3020 JJ=ST(IV): KK=ST(IV+1): LI=ST(1): MM=ST(5)
3030 GOSUB 6000
3040 SZ=RV
3050 DV=YR: I=0: J=60: K=10
3060 GOSUB 5000
3070 JJ=TT(IV): KK=TT(IV+1): LI=TT(1): MM=TT(7)
3080 GOSUB 6000
3090 TZ=RV
3100 DV=MS: I=0: J=10: K=1
3110 GOSUB 5000
3120 JJ=UT(IV): KK=UT(IV+1): LI=UT(1): MM=UT(11)
3130 GOSUB 6000
3140 UZ=RV
3150 DV=RZ/SZ: I=0: J=2: K=.5
3160 GOSUB 5000
3170 JJ=VT(IV): KK=VT(IV+1): LI=VT(1): MM=VT(5)
3180 GOSUB 6000
3190 VZ=RV
4000 REM *****
4010 REM * ALL TABLE LOOK-UPS NOW COMPLETE *
4020 REM * FIND NEW HATES & AUXILIARIES *
4030 REM *****
4040 PL=PL+DI*(BR-DR)
4050 IF TI=51 THEN CP=81 ELSE CP=8
4060 BR=PL*CP*HZ*AZ*GZ*(Z
4070 EC=CK*(1-AF)*BZ/(1-C)
4080 MS=EC/E
4090 IF TI=52 THEN (P=NS ELSE P=V2
4100 NU=PL*CP*JZ
4110 NL=NL+DI*(-NJ)
4115 NF=NL/N1
4120 IF TI=53 THEN (P=1) ELSE (P=1)
4130 DR=PL*CP*(Z*W)*Z*W*FZ
4140 CR=PL/(L*P1)
4150 IF TI=57 THEN (P=1) ELSE (P=1)
4160 FR=KZ+JZ+MZ*CP/F2
4180 IF TI=55 THEN (P=1) ELSE (P=1)
4190 CD=CL*CP
4200 IF TI=54 THEN (P=1) ELSE (P=1)
4210 CG=PL*LZ*CP
4220 CL=CL+DI*(G-1)D)
4223 CK=CL/PL
4227 CA=CK*AF/C
4230 IF TI=55 THEN (P=1) ELSE (P=1)
4240 PG=PL*CP*NZ
4250 PA=YL/DZ

```

(continued on page 83)

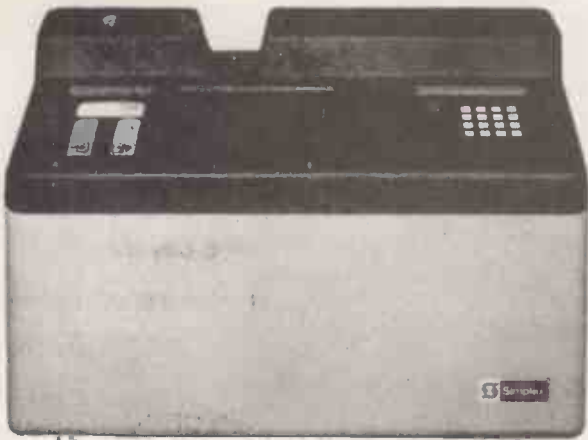

## AUTOMATE YOUR PAYROLL

- COMPLETE TIME ACCOUNTING
- USES TRADITIONAL STYLE CLOCK CARDS
- TIME CLOCK OPERATES INDEPENDENTLY OF THE COMPUTER
- HANDLES FLEXTIME, NORMAL TIME
- TOTALS HOURS ON CLOCK CARD
- ALSO CONNECTS TO THE MITREFINCH MINICOMPUTER

## A PAYROLL PACKAGE TO SUIT EVERYONE

Professionally written, and currently in use throughout the UK this package can be used either with or without the time clock. It is exceptionally easy to use and comes with complete documentation, it is very flexible allowing for precisely YOUR method of calculating pay. Features include: —

- PAY slips production
- CHEQUE and credit transfer printing
- TAX forms production (P60, P35, P11S)
- PAYROLL summary (tax, N.I., net pay, gross pay)
- TAX bands and N.I. tables may be altered by the user
- HOURLY, weekly, and monthly paid staff
- UP to four standard deductions per employee
- UP to four standard additions per employee
- UP to five overtime rates per employee
- UP to four non-taxable additions per employee
- NON STANDARD additions and deductions
- SAVINGS scheme
- PENSION payment and bonus
- COIN analysis for cash payments
- DEPARTMENTAL analysis
- EMPLOYEE leaving feature
- CHANGE all employee tax codes feature
- ALL NI letters
- ALL tax bands and codes
- UP to 150 employees/discette
- MIXTURE of cash/cheque/giro payments in any one pay



(continued from page 81)

```

4260 YL=YL+DI*(PG-PA)
4270 YR=YL/P2
4280 AF=AF+(DI/C7)*(PZ+VZ-WZ)
4290 DL=DQ+DI*WZ+SZ*TZ
4400 NEXT TS
4410 REM *****
4420 REM = GO TO MAIN MENU ROUTINE =
4430 REM *****
4440 GOSUB8000
4450 NEXT TI
4460 STOP
4970 REM *****
4980 REM = TABLE LOOK-UP MENU ROUTINE =
4990 REM *****
5000 IFDV=(ITHENS000)
5010 IFDV=JTHENS000
5020 IV=0
5030 FORTV=1/DTSTEPK
5040 IFDV=JTHENS007M
5050 IV=IV+1
5060 NEXT IV
5070 GOTO5110
5080 IV=1/DTSTEPK
5090 IV=INT((J-1)/K+1.05)
5110 RETURN
5970 REM *****
5980 REM = EXTRAPOLATION MENU ROUTINE =
5990 REM *****
6000 IFIV=INT((J-1)/K+1.05)THENS000
6010 IFDV=JTHENS000
6020 RV=J*(DV-(IV-1)*K)/K+(K-K*J)
6030 GOTO6050
6040 RV=MM+GOTO6050
6050 RV=LL
6060 RETURN
6070 REM *****
6080 REM = INITIAL OUTPUT ROUTINE =
6090 REM *****
7000 CLS:PRINT" WORLD-2 STANDARD RUN"
7010 PRINT:PRINT" MAIN LEVEL VARIABLES:PRINT
7030 PRINTSS
7040 PRINT"POP "PL" BIRTH RATE "BR" DEATH RATE "DR
7050 PRINT"NL "NL" "QL" "QL" "VL" "VL
7060 PRINT"CL "CL" "AF" "AF
7070 PRINT"MS "MS" "FR" "FR" "NU" "NU
7080 PRINT"NF "NF" "QZ" "QZ" "RZ" "RZ
7090 PRINT"QF "QF" "SZ" "SZ" "TZ"
7100 PRINT"=1, TS, PL, BR, DR, NL, QL, VL, DL, AF, MS, FR, NU, NF, RZ, QZ, SZ, TZ
7200 RETURN
7970 REM *****
7980 REM = MAIN PLOT ROUTINE =
7990 REM *****
8000 REM = INCLUDES OUTPUT TO TAPE =
8030 PRINT TI+4
8040 PRINT"POP "PL" BIRTH RATE "BR" DEATH RATE "DR
8050 PRINT"NL "NL" "QL" "QL" "VL" "VL
8060 PRINT"CL "CL" "AF" "AF
8070 PRINT"MS "MS" "FR" "FR" "NU" "NU
8080 PRINT"NF "NF" "QZ" "QZ" "RZ" "RZ
8090 PRINT"QF "QF" "SZ" "SZ" "TZ"
8210 PRINT"=1, TS, PL, BR, DR, NL, QL, VL, DL, AF, MS, FR, NU, NF, RZ, QZ, SZ, TZ
8300 RETURN
9000 REM *****
9010 REM = INITIAL INPUT OF LIFE ROUTINE =
9020 REM *****
9050 DV=MS:I=0:J=5:K=1
9060 GOSUB8000
9070 JJ=GT(IV):KK=GT(IV+1):LL=ST(1):MM=ST(6)
9080 GOSUB6000
9090 QZ=RV
9100 DV=CR:I=0:J=5:K=1
9110 GOSUB5000
9120 JJ=RT(IV):KK=RT(IV+1):LL=RT(1):MM=RT(11)
9130 GOSUB6000
9140 RZ=RV
9150 DV=FR:I=0:J=4:K=1
9160 GOSUB5000
9170 JJ=ST(IV):KK=ST(IV+1):LL=ST(1):MM=ST(5)
9180 GOSUB6000
9190 SZ=RV
9200 DV=YR:I=0:J=60:K=10
9210 GOSUB5000
9220 JJ=TT(IV):KK=TT(IV+1):LL=TT(1):MM=TT(7)
9230 GOSUB6000
9240 TZ=RV
9250 DL=DQ+QZ+RZ+SZ*TZ
9260 RETURN
10000 REM *****
10010 REM = INITIAL RESOURCE USAGE RATE =
10020 REM *****
10030 DV=MS:I=0:J=10:K=1
10040 GOSUB5000
10050 JJ=UT(IV):KK=UT(IV+1):LL=UT(1):MM=UT(11)
10060 GOSUB5000
10070 UZ=RV
10080 NU=PL+N2+UZ
10090 RETURN
10970 REM *****
10980 REM = INITIAL BIRTH RATE =
10990 REM *****
11000 DV=MS:I=0:J=5:K=1
11010 GOSUB5000
11020 JJ=AT(IV):KK=AT(IV+1):LL=AT(1):MM=AT(6)
11030 GOSUB6000
11040 AZ=RV
11050 DV=CR:I=0:J=5:K=1
11060 GOSUB5000
11070 JJ=BT(IV):KK=BT(IV+1):LL=BT(1):MM=BT(6)
11080 GOSUB6000
11090 QZ=RV
11100 DV=FR:I=0:J=4:K=1
11110 GOSUB5000
11120 JJ=HT(IV):KK=HT(IV+1):LL=HT(1):MM=HT(5)
11130 GOSUB6000
11140 HZ=RV
11150 DV=YR:I=0:J=60:K=10
11160 GOSUB5000
11170 JJ=IT(IV):KK=IT(IV+1):LL=IT(1):MM=IT(7)
11180 GOSUB6000
11190 IZ=RV
11200 BR=PL+M+HZ+AZ+IZ
11210 RETURN
11970 REM *****
11980 REM = INITIAL DEATH RATE =
11990 REM *****
12000 DV=MS:I=0:J=5:K=1
12010 GOSUB5000
12020 JJ=CT(IV):KK=CT(IV+1):LL=CT(1):MM=CT(11)
12030 GOSUB6000
12040 OZ=RV
12050 DV=YR:I=0:J=60:K=10
12060 GOSUB5000
12070 JJ=DT(IV):KK=DT(IV+1):LL=DT(1):MM=DT(7)

```

Figure 5.

```

10 DIM GV(51), PL(51), BR(51), DR(51), NL(51), QL(51), VL(51), DL(51)
20 DIM AF(51), MS(51), FR(51), NU(51), NF(51), RZ(51), QZ(51), SZ(51)
30 DIM TZ(51)
40 CLS
50 L1=0:L2=5:L3=1.0
100 FOR I=1 TO 51
110 INPUT "I,T,P,A,C(B),R(C),D(R),N(L),Q(L),V(L),D(L),F(C),M(S),FR(C),NU(I),NF(C),RZ(C),QZ(C),SZ(C),TZ(C)
130 PRINT T
140 PRINT "POP "PL(C)" B. "BR(C)" D. "DR(C)
150 PRINT "NL "NL(C)" QL "QL(C)" VL "VL(C)
160 PRINT "CL "CL(C)" AF "AF(C)" MS "MS(C)
170 PRINT "FR "FR(C)" NU "NU(C)" NF "NF(C)
180 PRINT "RZ "RZ(C)" QZ "QZ(C)" SZ "SZ(C)" TZ "TZ(C)
190 NEXT I
200 INPUT "PRESS ANY KEY TO CONTINUE"
220 CLS
230 PRINT"HERE IS A LIST OF PHYSICAL QUANTITIES THAT MAY BE PLOTTED"
240 PRINT"VS. TIME. THEIR CODE NUMBERS FOLLOW THEIR DESCRIPTIONS."
250 PRINT"PLEASE NOTE THE CODE NUMBER IS THE QUANTITY YOU WISH TO"
260 PRINT" PLOT."
270 PRINT" 1. POPULATION      " 2. BIRTH RATE"
310 PRINT" 3. DEATH RATE      " 4. NATURAL RESOURCES LEVEL"
320 PRINT" 5. QUALITY OF LIFE  " 6. POLLUTION LEVEL"
330 PRINT" 7. CAP. INVEST. LEV. " 8. CAP. INVEST. AG. FRACTION"
340 PRINT" 9. MAT. STAND. LIVING " 10. FOOD RATIO"
350 PRINT" 11. RESOURCE USAGE RATE" 12. RESOURCE FRACT. REMAINING"
360 PRINT" 13. O.I.L. DRILLING   " 14. O.I.L. MAT. STAND. LIVING"
370 PRINT" 15. O. L. FOOD      " 16. O.I.L. POLLUTION"
410 PRINT" A CODE NO. OUTSIDE RANGE 1-16 TERMINATES PROGRAM"
420 INPUT"VARIABLE CODE NUMBER (1-16) : "
430 IF INT(VN) (1) OR INT(VN) (16) THEN 2440
435 US="MAXIMUM"
440 ON VN GOTO 450,460,470,480,490,500,510,520,530,540,550,560,570,580,590,600
450 V0="POPULATION LEVEL" :FOR I=1 TO 51:GV(I)=PL(I):NEXT I:GOSUB1000
455 INPUT A$;GOTO220
460 V0="BIRTH RATE" :FOR I=1 TO 51:GV(I)=BR(C):NEXT I:GOSUB1000
465 INPUT A$;GOTO220
470 V0="DEATH RATE" :FOR I=1 TO 51:GV(I)=DR(C):NEXT I:GOSUB1000
475 INPUT A$;GOTO220
480 V0="NAT. RES. LEVEL" :FOR I=1 TO 51:GV(I)=NL(C):NEXT I:GOSUB1000
485 INPUT A$;GOTO220
490 V0="O.I.L. DRILLING" :FOR I=1 TO 51:GV(I)=DL(C):NEXT I:GOSUB1000
495 INPUT A$;GOTO220
500 V0="POLLUTION LEVEL" :FOR I=1 TO 51:GV(I)=VL(C):NEXT I:GOSUB1000
505 INPUT A$;GOTO220
510 V0="CAP. INV. LEV." :FOR I=1 TO 51:GV(I)=CL(C):NEXT I:GOSUB1000
515 INPUT A$;GOTO220
520 V0="CAP. INV. AG. FRACT" :FOR I=1 TO 51:GV(I)=AF(C):NEXT I:GOSUB1000
525 INPUT A$;GOTO220
530 V0="MATERIAL STAND. LIF" :FOR I=1 TO 51:GV(I)=MS(C):NEXT I:GOSUB1000
535 INPUT A$;GOTO220
540 V0="FOOD RATIO" :FOR I=1 TO 51:GV(I)=FR(C):NEXT I:GOSUB1000
545 INPUT A$;GOTO220
550 V0="RES. USAGE RATE" :FOR I=1 TO 51:GV(I)=NF(C):NEXT I:GOSUB1000
555 INPUT A$;GOTO220
560 V0="RES. FRACT. REMAINING" :FOR I=1 TO 51:GV(I)=NF(C):NEXT I:GOSUB1000
565 INPUT A$;GOTO220
570 V0="O.I.L. DRILLING" :FOR I=1 TO 51:GV(I)=DL(C):NEXT I:GOSUB1000
575 INPUT A$;GOTO220
580 V0="O.I.L. MAT. STAND. LIF" :FOR I=1 TO 51:GV(I)=VL(C):NEXT I:GOSUB1000
585 INPUT A$;GOTO220
590 V0="O.I.L. FOOD" :FOR I=1 TO 51:GV(I)=SZ(C):NEXT I:GOSUB1000
595 INPUT A$;GOTO220
600 V0="O.I.L. POLLUTION" :FOR I=1 TO 51:GV(I)=TZ(C):NEXT I:GOSUB1000
605 INPUT A$;GOTO220
1000 CLS
1001 PRINT@15,V0
1002 PRINT@40,U0
1010 MV=0
1020 FDI=1/DTSTEPK
1030 V0=GV(I)
1040 IF U0 MV THEN MV=V
1050 NEXT I
1053 C=0
1055 IF MV(1) THEN DV=MV
1056 IF MV(1) THEN I1=0
1060 DV=MV/I1
1070 IF DV(1) THEN I1=I1+95
1080 DV=I1/I1+95
1090 GOTO1070
1095 C=C+1
1100 IF DV(1) THEN F=4
1110 IF F=4 THEN I1=0
1120 IF DV(1) THEN F=2
1130 IF F=2 THEN I1=0
1140 F=1
1150 REM
1200 DV=INT(1000+DV+.5)/1000
1210 PRINT@50,DV;"X1000"
1220 PRINT@120,"0000 000 000 000 000 000"
1230 PRINT@773,1.1
1240 PRINT@196,1.3/F
1250 PRINT@516,1.2/F
1260 PRINT@841,"1980"
1270 PRINT@894,"2000"
1280 PRINT@889,"2100"
1290 FOR I=9 TO 30
1300 SET(20,I)
1310 NEXT I
1320 FOR I=21 TO 121
1330 SET(1,30)
1340 NEXT I
1350 FOR I=0 TO 50
1360 PV=GV(I+1)/(I+1)
1370 PV=INT(30+PV+.5)
1380 PV=39-PV
1385 IF PV(9) THEN PV=9
1390 IF PV=39 THEN MV=50
1400 SET(20+21,PV)
1410 NEXT I
1420 PRINT@925,"PRESS ANY KEY TO CONTINUE"
2000 STOP

```

# Larrs' Ghost

Larrs' ghost still haunts his make-believe world; even now he warms his feet on the glittering sands, dodging the bubbling surf like a child. So long as power is ensured to the computer and bio-interface, Larrs' intricate program will reveal his carefully-constructed world to anyone who wishes to enter it.

Many times I sought him out and begged him to return to the real world. Here he looked well. His eyes were bright and his skin was pink and youthful; the real world had clouded his eyes and sallowed his skin.

"This is my world", he once replied with pride. We sat at the beach-head, warmed by a mellow sun. The burnished disc of the sea stretch to the horizon and the mare's-tails of summer clouds swept the blue sky overhead.

"Larrs, please listen to me. Your body in the real world is slowly deteriorating. As your doctor, I must advise you to return to it".

"Why? For my spirit to die along with that miserable shell? Here, my soul has freedom", he said sharply.

"Freedom until your body dies of neglect", I argued. "Then what is there to interact with your carefully-programmed world"?

His eyes pierced mine with such intensity that for the first time I sensed his unreality. It frightened me.

"Look around you, my friend, and what do you see? A beach, clean, uncluttered". He stepped forward and scooped a handful of water from a nearby rock-pool. "The sea is clear, unpolluted. Why is this so? I know as well as you that in the real world we are in some grubby little room in a decaying building, in the middle of a stinking city, but in my world I can set things right; the interaction between my mind and the computer enables me to set things right".

"It is nothing more than escapism, Larrs. Like watching television, fleeing the real world".

"It is more than that, my friend. Remember long ago when I first started this project"?

"Your enthusiasm was infectious, but you saw it as nothing more than another form of entertainment or educational tool; experiencing images, sounds, smells directly in the mind, generated by a cold and logical machine".

"I was wrong", he enthused. "It is more than entertainment. It is a new life in a new world, limited only by my imagination. The computer not only

stimulates my mental senses to tell me what I should see and hear and smell, but I tell it. Imagination becomes an apparent reality. Because of the bio-interface directly to my senses, I cannot tell it from reality — but I can remove the darker aspects of the real world".

It was realistic. I remember shaking Larrs' hand on first greeting him. It was firm and warm. I had difficulty imagining that grubby little room in which both our bodies reclined on couches. With sensors

---

by Chris Kelly

---

wired to our heads we looked like futuristic Hydra.

"Yet how can all these images and sounds be stored in a limited computer memory"? I had asked him long ago. "Not all parts of the image are stored", he had replied, "just the required train of impulses to trigger the mind into reconstructing the images. For example, one does not memorise a scene point-by-point like a television picture. Only key parts of it are remembered. The human mind fills in the rest of the detail".

This seemed true. I remember testing this theory by visualising the scene behind me — a small hill surrounded by trees and a small log cabin tucked in at one side. When I turned and looked at it critically, I realised that the components were standard images drawn from my memory, put together rather like an identi-kit picture. A few distinguishing features had been added to make the scene individual.

To me it was little more than a technological trick, like sitting in a cinema and pretending that the world outside does not exist. Eventually all good films end.

"You cannot hide forever, Larrs. Your body needs attention, exercise. Do you realise that you are being fed intravenously? You're loading the responsibility of your body on to others".

"Then kill it", he snapped with such ferocity that I almost shrank back from my old and trusted colleague. The surf hissed through the sand. I told myself it was not real, but to Larrs it was. As I returned to the real world, I began to seriously suspect his sanity.

Later that day I did a run-through the regular medical checks on Larrs. He lay on a couch, his senses isolated from the room around him. They were

responding to the brighter music returned from the computer by his side.

Apart from the sensors wired to the bio-interface, other electrodes monitored his bodily functions. A drip was suspended above the couch feeding him. My machines told me of his weakening condition. For the first time I contemplated removing him from the computer without his consent, but fate acted before I did. Larrs' body went into violent spasms, then lay still. The cardiograph read-out dropped to zero.

I tried to revive him, but failed. His body was now indeed a miserable shell, empty and dead. For a while I sat mourning the loss of a friend and a brilliant mind, but eventually told myself that Larrs' mind had been lost to his computerised world long ago.

Reluctantly, I removed the electrodes from his head and placed them by the computer, which buzzed faintly as though searching the loops and subroutines, looking for external impulses with which to react. I reached out to switch it off, but on a moment's impulse checked the movement. I felt as though Larrs himself was forbidding me.

Although Larrs' main program was permanently stored on disc, its interpretation of his make-believe world would be lost forever if I now switched it off, thus erasing the working store. For months, the computer had detected the signals from his brain, interpreted them and restructured the basic program to feed back the images of Larrs' imagination. It occurred to me that even though Larrs was dead, his world still existed.

There and then I decided to re-enter Larrs' world to observe the artefacts of his mind. What could I learn of a dead man from the structure and contents of a world as he saw it?

I lay on the couch, disregarding the sombre fact that Larrs' lifeless body lay beside me. Within seconds, I entered the self-induced trance necessary to isolate myself from the real world and to open my mind with the probing sensors, interacting with the long and complex program Larrs had devised.

I found myself once more at the beach-head. It was day and comfortably warm. Gulls and kittiwakes wheeled and screeched in the sky above the distant cliffs. Close by the hill was the cabin, the only building in sight. Smoke curled from the chimney as though someone were home. I decided that the cabin would tell

me more of Larrs than anything else and went in.

Inside, I found spacious rooms filled with simple furniture. I could hear music, Rimsky-Korsakov's *Scheherazade* — Larrs' favourite — but no source that I could detect. I smelled cooking, and I made my way into the kitchen, I noticed a fireside rocking chair, rocking slightly as though someone had recently left it. A wholesome-smelling stew was simmering gently in a large pot on the stove and I was puzzled to see the pine table set for two.

The outside door suddenly opened and I jumped back as a man entered carrying logs for the fire. He stopped and stared.

"Larrs", I gasped aloud without realising. My mind raced feverishly until I convinced myself that this was probably only an image; an echo of a dead man, reconstructed in response to my brain impulses. Then he spoke to me:

"Welcome, my friend doctor. As you can see, I still do the daily chores I choose; the homely chores, you understand, that add to the realism". He beckoned to the table. "Food"?

"You expected me"? I ventured to ask, wondering what kind of interactive answer the computer would generate.

"I felt something had happened", he replied simply. "A kind of snapping

of strings, a sense of release". Again his eyes probed mine.

I grasped his shoulders, firmly. "Larrs, your body is dead. You died not half-an-hour ago".

He sagged slightly, and sat down slowly. Presently he looked up at me. "Only my body died, doctor. Please, when you return to the real world, do not switch the computer off".

Larrs still haunts his make-believe world; he still warms his feet on the sand and dodges the unpredictable surf. So long as power is ensured to the computer, anyone can don the electrodes and interact with his spirit. □

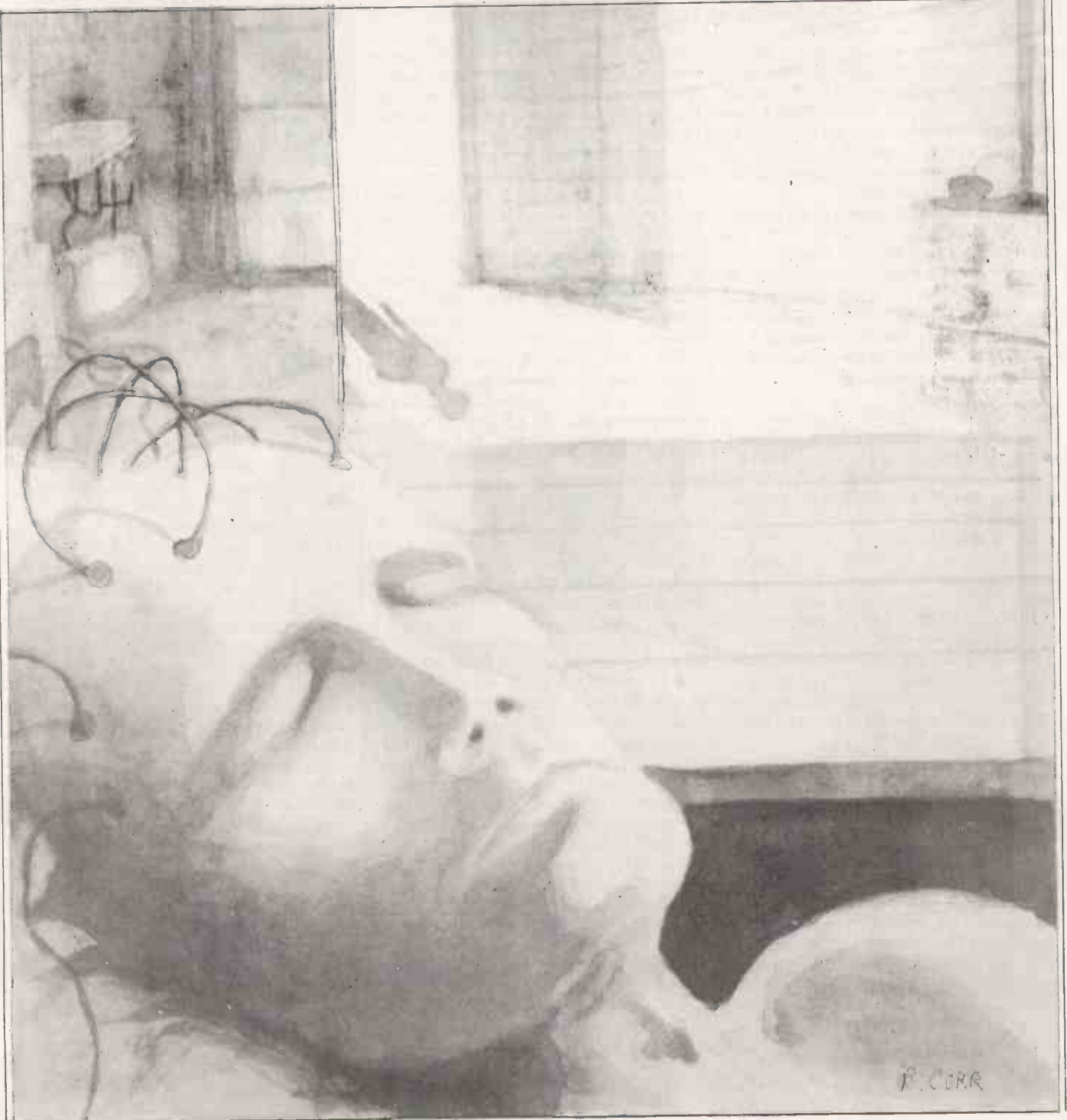

# Creativeness is the key

Ed James looks critically at the current role of computing in schools and considers, in particular, the impact which microcomputers are having on the teaching.

SUPPORTED by various statements from the Government, many schools are buying microelectronic equipment and starting to involve their students in computing with no clear understanding of what they are trying to achieve.

My purpose is to spell out some of the problems which schools may encounter and to present what I hope is a constructive view of a sensible way to progress.

My first concern is the lack of adequate support for the establishment of computing in a school. Many advertisements try to persuade us that it is necessary to purchase only a modest amount of hardware and to make a start in computing. That may be true for the hobbyist who is prepared to dedicate all his efforts to making something work, but it is just not true in schools.

If there are many students, the setting-up of a computing service for them is a highly-skilled job. There is a danger that the teacher responsible for computing will spend much time in the administration of this activity and will, therefore, have no time to provide the teaching which is necessary, particularly for the less able students.

## Software support

For many of the significant applications of computers in schools it will be necessary to provide a wide variety of software support which is not available at the moment.

My second concern is related to the first. Since it is so difficult to start a computing service which gives a large number of students access, it is likely that the use of the computer will be restricted to a comparatively small elite of pupils.

We will have the equivalent of a ham radio club for a small number of students and they will delight in learning the sophisticated techniques and developing the impenetrable jargon.

The students who are not allowed to use the computer may well develop an antagonism towards computing which they feel is not for them which could sow the seeds of a Luddite mentality in later years.

Another of my concerns is the lack of appreciation of what computing is really about. In my experience, the majority of school teachers believe it is concerned directly with mathematics and assume that only the mathematicians will become involved in computing.

Nothing could be further from the truth. While computing arose originally to assist mathematical computations, the use of computers has spread to totally non-numeric fields and the applications in commerce are now far

more significant than those in numerical computation.

On the other hand, there is clearly considerable confusion in Government circles over microelectronics and computing. It is believed necessary to have training in electronics to cope with computers. Again, this is a myth.

If computing is not those things, what is it? At the moment, it is very much a craft skill related closely to essay writing or the creation of poetry or music. There is a good deal of engineering intuition involved and a comparatively minor amount of conventional science. Again, it is not a question of learning a language but about learning to do things with that language. That involves showing by example. Of course the vital attribute we fail to teach is the ability to create.

It is difficult to say positively what is required but it is certain that teaching must be carried out by someone with very wide practical experience or if that is not possible, they must be very trained effectively by people with wide experience. If that is not the case, all kinds of misunderstandings are likely to occur.

The final danger I must stress is a much more comprehensive one — the danger of a new technological elitism which could lead to a Luddite response from the underprivileged. Let us ask a simple question of the school administrator. What use is one microcomputer in a school of 2,000 children?

It is clear that there is no way of organising so that all the children have significant experience with the micro-computer. What happens in practice is that a ham teacher with a hobbyist's outlook sees it as an exciting opportunity and through ineffective teaching methods develops an elite group who are able to understand the computer in spite of the lack of training and who, of course, can discover how to do things for themselves.

That small group is likely to dominate the use of the computer and those children who were less forward in grasping the opportunity will find that the way to obtaining further experience is difficult.

The elite group will soon learn the jargon considered necessary in talking about computers and will see it as a private language which can be used to exclude other people.

It is likely that the less privileged will also be affected by other inhibitions such as their feeling of inferiority in mathematics which could colour their approach to computing — however wrongly.

The recent Government announcement of 100 free microcomputing systems is just

the type of support likely to develop the situation described. Having indicated the problems, let us move to the remarkable opportunities which are becoming available and may be grasped if we can organise ourselves properly.

The new opportunity is really the existence of an exciting subject in which all children can be involved in a creative way. The subject is not microelectronics or computing science or mathematics. It is information engineering.

In a sense, we are already information engineers. We obtain information from outside sources, we process it and use it to benefit from it. Currently, the methods of obtaining and processing information are increasing in an explosive manner.

## Information is power

There is no doubt that the possession of information is power and so there is a need for everyone to learn how to use the new sources of information and how to learn to specify how the information may be processed for their own purposes. Otherwise, they will be left behind.

The opportunity, in effect, is that of a new generation who are not scared of information technology and are able to make use of it. The result of not taking the opportunities which we now possess is to produce a segregation into the haves and the have-nots with all the revolutionary attitudes that will produce.

I believe the emphasis in training should be on the applications of computing systems, not on their design. The emphasis on explanation should be at the overall planning level and computer applications should be motivated by an obvious requirement for a particular purpose. The applications should be chosen carefully to relate to possible interests of the students.

In addition, there should be attention to applications which all students are likely to encounter — such as the various types of information system provided for public use. Below the planning level there should be appreciation of programming as a means to a purposeful end.

Again, there should be an appreciation of how the program is executed in the machine so that the need for a particular kind of machine can be motivated from what it is required to do. I believe that the present emphasis on microelectronic detail to be a passing phase.

Although microelectronics will be very significant in the future, the overall way in which we think of computing is not altered by it in any essential way. The

students are, therefore, really being asked to learn about computing in general rather than about microcomputing in particular.

That description of what is required may appear simple-minded and obvious but it should be noted that the method suggested is in strong contrast to the training which is typically provided. So often at present, the student is led directly into some low level of programming and not a word is said about the purpose of these programs.

Often, the choice of subject for programming is some trivial mathematical calculation which helps to reinforce in the student's mind the connection between computing and mathematics. To be fair, that is the material taught because it is the material which exists in the text books.

It is also, unfortunately, unlikely that any teacher has had sufficient experience of practical computing to be able to relate a program to a practical significant application.

The problem of what to teach can be solved, at least partially, by the provision of a small number of adequate text books. They are provided for more easily than adequate computing facilities for all members of existing schools. Even more difficult to plan is how the large number of teachers who will be required to train students can be found and supported adequately.

We may perhaps look to a continuing decrease in the cost of personal-

computing facilities and, therefore, hope that the school-computing facilities can be supplemented by those available in homes, and in public places but there is no similar obvious solution to the problem of teacher training.

It seems that there is a desperate need to establish a system of national training centres for teachers in schools and colleges. These centres need to provide courses of varying lengths to suit the requirements of all teachers and need to cover all aspects of the training required for the general student.

### Training centres

The emphasis in these training centres must, of course, be on practical applications and practical aspects of computer use and training in use. While it seems essential that the national centres will be related closely to existing centres of expertise, it is important that the type of training provided should not be related too strongly to the more academic view of computing held in many universities.

To support the teacher on return to full-time teaching, it will be important to extend considerably the number of support centres which have been so ably pioneered in local education areas such as Birmingham and Hertfordshire. Such organisations need to be formed in every part of the country.

One of their most important functions will be to promote the purchase of

standardised computing facilities which can then be available for use together with a wide range of programming support packages produced by professionals.

The involvement of the teacher in specifying teaching aids and carrying out the instruction should not be confused with the writing of programs or providing operating systems management. The only possible economic way of providing the expertise required is to centralise the sources.

A satisfactory service can be provided only by full-time professionals and it will be essential for those professionals to have a total commitment to simple-to-use systems.

In conclusion, I would see that the purpose of the training is the promotion of an information-rich society where the sources and means of processing information are not in the hands of a small elite. Computing systems should be seen by all as aids to obtaining and processing information and, therefore, extending our mental powers.

In particular, every student needs sufficient support to develop a confidence towards computing systems so that they will not be led astray by extremists who say on the one hand, that computers must be destroyed or on the other hand, that they can do everything for everybody and so devalue human beings. I hope that we can all contribute to the effort which is required in the future. □



# FOR THE SINCLAIR ZX-80

This unique book contains 30 programs all designed to fit in the basic 1K version of the SINCLAIR ZX80!!

With this book you will realise that the ZX80 is more powerful than you ever imagined! 112 pages packed full of solid information!

**BLACKJACK** — actually contains a full pack of cards, shuffles them, keeps track of the dealer and player totals, and the money bets, all within 1K.

**DR. ZX-80** — a truly conversational program: DR. ZX-80 is your personal computer analyst.

**LINE RENUMBER** — an invaluable program which automatically renumbers lines and puts order to your programs.

**MEMORY LEFT** — an incredible routine especially useful with only 1K, which lets you know to the byte how much memory is left. This also illustrates USR routines.

**GOMOKU** — the computer challenges you to this complex Japanese game, Incredibly this program including display of the 7x7 board fits into 1K — it only does so because it uses the display as memory!

Other programs included are **HORSE RACE**, **LUNAR LANDER** (with moving spaceship display), **NOUGHTS AND CROSSES**, **NIM**, **SIMPLE SIMON**, **HANGMAN**, **LIFE**; **MASTERMIND**, **PINCH** and 16 others!

OTHER BOOKS IN PREPARATION INCLUDE 'ZX-80 MACHINE LANGUAGE PROGRAMMING'.

available by mail order only

**£6.95** (plus 50P p&p)

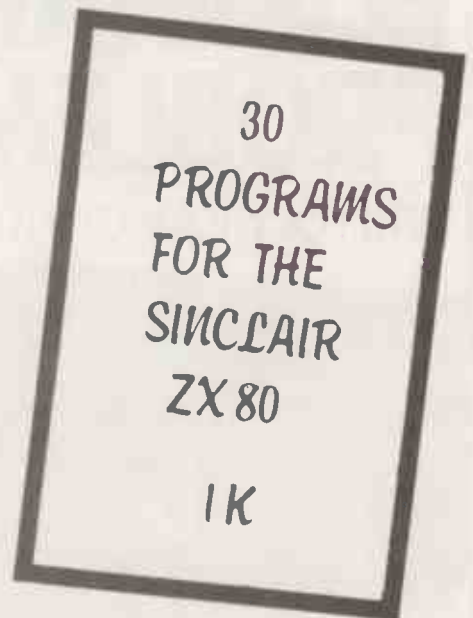

MELBOURNE HOUSE PUBLISHERS

Orders to: 131 Trafalgar Road, London SE10  
Correspondence: Glebe Cottage, Glebe House, Station Road, Cheddington, Leighton Buzzard, Beds.

Please send me ..... copy/ies of '30 Programs for the ZX-80: 1K'

NAME: .....

ADDRESS: .....

..... POSTCODE: .....

Please enclose cheque or P.O. for £7.45 per copy. Orders outside the U.K. £7.95

• Circle No. 169

# POWERFUL MICROS AT THE RIGHT PRICE

- Multi-User ● Multi-Tasking
- Multi-Language ● Hard Disc Storage ● Word Processing
- Priced from under £5000

Languages supported include – Basic, Cobol, Fortran.  
OEM, Educational and Dealer enquiries invited

## EQUINOX

COMPUTER SYSTEMS LIMITED  
Kleeman House, 16 Anning Street  
New Inn Yard, London EC2A 3HB  
Tel: 01-739 2387 & 01-729 4460



# ELIMINATE YOUR BACK-UP PROBLEMS

with our low cost cartridge drive



The Equinox KB10 Cartridge Drive allows S100 microsystems to transfer, read and write data at high speed. Its 5MB fixed and 5MB removable discs eliminate the need to provide separate data back-up. The removable 5MB disc allows for fast back-up and therefore unlimited off-line storage. Without sacrificing high performance, multiple users can operate the Equinox KB10 simultaneously using multi-user software. Equinox provides support for such software i.e., MVT/FAMOS, MP/M and OMNIX. CP/M is also supported.

## EQUINOX

COMPUTER SYSTEMS LIMITED

Kleeman House, 16 Anning Street, New Inn Yard,  
London EC2A 3HB. Tel: 01-739 2387/9 and 01-729 4460

PRICE  
**£3950\***  
PLUS VAT

\*One-off OEM price

• Circle No. 170



# Future of packaged software

IT IS probable that sales of programmable computers in the U.K. are being made at the rate of about 5,000 a month. Only a few of those computers will be sold to people unaware of the fact that a computer requires to have a set of programs before it can be employed on useful work.

By the same token, very few of the buyers expect to either write their own programs or have programs specially written. There is just not the programming capacity within the U.K. to meet the original requirements of 5,000 computers per month.

The buyers are usually supplied a set of programs along with their machine. Those programs are in the form of a package. Package programs are available for most business applications and to suit the needs of a wide variety of trades and professions.

The computer purchaser is attracted by the power of the packages. It is the facilities offered by the package that he is really buying, the computer becoming the bare vehicle required to run the package.

There is a wide choice of packages available. The consensus of those who have attempted to use them is that they are of generally poor quality. Even expert examination of a package may not reveal its weaknesses.

The reason for the low quality of the products is, in our view, sheer lack of experience. It will be necessary to go through several development cycles of producing and improving packages before good-quality products are available.

## Development cycles

The development cycles and the production of the higher-quality packages will require considerably greater investment than has been made in the packages offered today.

The programmer needs applications' knowledge because this type of individual does not work from a written specification but carries the whole solution in his head and writes program code in one continuous stream. Interestingly, program code written in that way by the best programmers is usually of very good quality.

A package written in two man months in the manner we have described can be marketed for £1,000. Over the first two years of its life, it would expect to sell 100 copies and just about break even after the programmer originator had received a reasonable remuneration.

Most of the software on offer today has been produced in that way and it is hardly really surprising that users should regard it with generally poor opinions.

A company wishing to develop a program product and prepared to invest to the necessary extent has to go through the full gamut of product innovation, proving and development cycle.



After the initial market research, a features list needs to be prepared setting out the points the package will cover. The marketing plan will show how it is to be presented and that leads to the first specification of the system.

Based on that specification, a prototype system can be developed and tested in the field. Ideally, those tests should be with users who will eventually become the first reference sells. With that field experience,

by Cliff Dilloway

the final specification of the product can be produced and the programs and documentation prepared.

The sales staff have to be trained and the sales-support staff given experience on the product. Anticipating sales and technical-support team should be ready to establish installations and a continuing programme of enhancements must be prepared.

Development of a product in that way cannot possibly be done for less than £100,000 and a realistic figure is probably several times that amount. Unfortunately, there is no objective measure of the quality of the finished product and so it may well be found that the product will sell no better than our genius programmers home-grown, two-month effort.

It is clear that it is sales effort which sells packages and not the intrinsic quality of the packages themselves. That is because it is an unsophisticated market and the buyers are not able to judge the relative worth of what they are offered.

It is that phenomenon which gives rise to the low regard in which package of software is often held.

The description so far will be recognised readily by anyone who has participated in the market as supplier, purchaser or investor. What we have been examining are the symptoms. The causes are more fundamental and are at the heart of the use of a computer.

The greatest difficulty is that contrary to popular belief, commercial practice is almost completely undefined. It is by far

easier to say what is not acceptable commercial practice than it is to say what is acceptable. Certainly auditors work that way.

We give the invoice as an example. A description of an invoice would apply to a number of other documents which are certainly not invoices.

For those who dispute the vagueness, we would point out the many directory invoices that somehow seem to get paid without any justification whatsoever. Knowing an invoice when you see one is not quite the same thing as being able to produce a definition in the detail required by a computer system.

Remember we are seeking to produce a specification not just for an invoice but for all the different invoices anyone might require.

Another factor is that every user's requirements are different. That is a matter of received wisdom which tends to defeat the whole idea of the production of commercial applications packages. In fact, while every user's requirements are different no user has a requirement which is without parallel.

## Clear conclusions

The conclusion we reach is that much more effort has to be put into instruction and education on the use of specific program packages. In fact, packages must be designed so that they can be sold, installed and used.

When the problems of how to provide understanding have been solved, it will be much easier for a prospective user to judge whether a package is suitable for him.

Such a judgment will have a profound effect on the production and marketing of software. The confidence of users will increase as they discover how to reject unsuitable software.

Sales of suitable products will increase yielding a profit to their innovators. That profit can take its rightful place as the reward by society to those it judges a success so that they may continue their good service to society.

# Design techniques which save time and reduce effort

How often after implementing a program have you wished you could start all over again — this time you would do it differently? Brian Swindells describes easier program maintenance.

HOW OFTEN, when using a program you wrote some time ago have you wished for additional features? They are not uncommon problems and, of course, are only to be expected. By implementing a program, we gain additional experience by which, if we re-wrote it, we could benefit. As we use a program, we gain even more experience which changes our requirements, usually making them more sophisticated.

## Common problems

Although those are common problems and are ones that probably cannot be eliminated completely, at least we can take steps to minimise them. By using advanced design techniques it is possible to ensure that our program can be amended easily to reflect changing requirements in changing situations. Those techniques can be summarised as:

- A functional approach
- The use of simple procedures
- The use of tables
- Parameter-driven
- Having good documentation

It is assumed that each program is written to achieve some pre-defined objective and that to achieve this, certain other objectives must be met. If, for ex-

ample, the main purpose of a program is to control a bank account; it is necessary to perform the following functions:

- Record details of items credited to account
- Record details of items debited to account
- Enquire on current state of account
- Report on exception conditions

The important aspect of those functions is that we need to perform them irrespective of how we achieve the objective. We may record the items in a ledger using a quill pen or we may record them electronically using a computer. The how may change, but the what does not.

As a first approach to good design, therefore, it is important to identify all the functions associated with the task at hand, be they functions of a complex business situation or the functions of a game.

## Functional analysis

That process is known as functional analysis and in undertaking the work it is advisable to forget about the computer altogether — just ensure you are fully aware of what you are setting out to achieve.

Having identified all the functions associated with the task it may be necessary to write several programs to cope

with the problem satisfactorily. If that is so, each program should comprise an integral number of functions making it more likely that subsequent changes will affect only one program.

## Simple procedures

The next step is to design simple procedures as solutions to how each function is to be undertaken. That can be considered as a further breakdown of the functional hierarchy described and if we take the posting of debits, the following simple procedures could apply:

- Post debit when cheque raised
- Post confirmation from bank statement
- Report on discrepancies
- Highlight cheques of more than £100
- Report if account overdrawn

This approach can be shown diagrammatically — figure 1 — and its advantage is that should you wish to change or add a procedure, it is self-contained and its relationship to other procedures can be readily identified.

It may be appropriate to continue breaking-down these procedures until there are many levels of the hierarchy. The decomposition is necessary until each self-contained procedure is simple enough to be converted into a small number of

Figure 1.

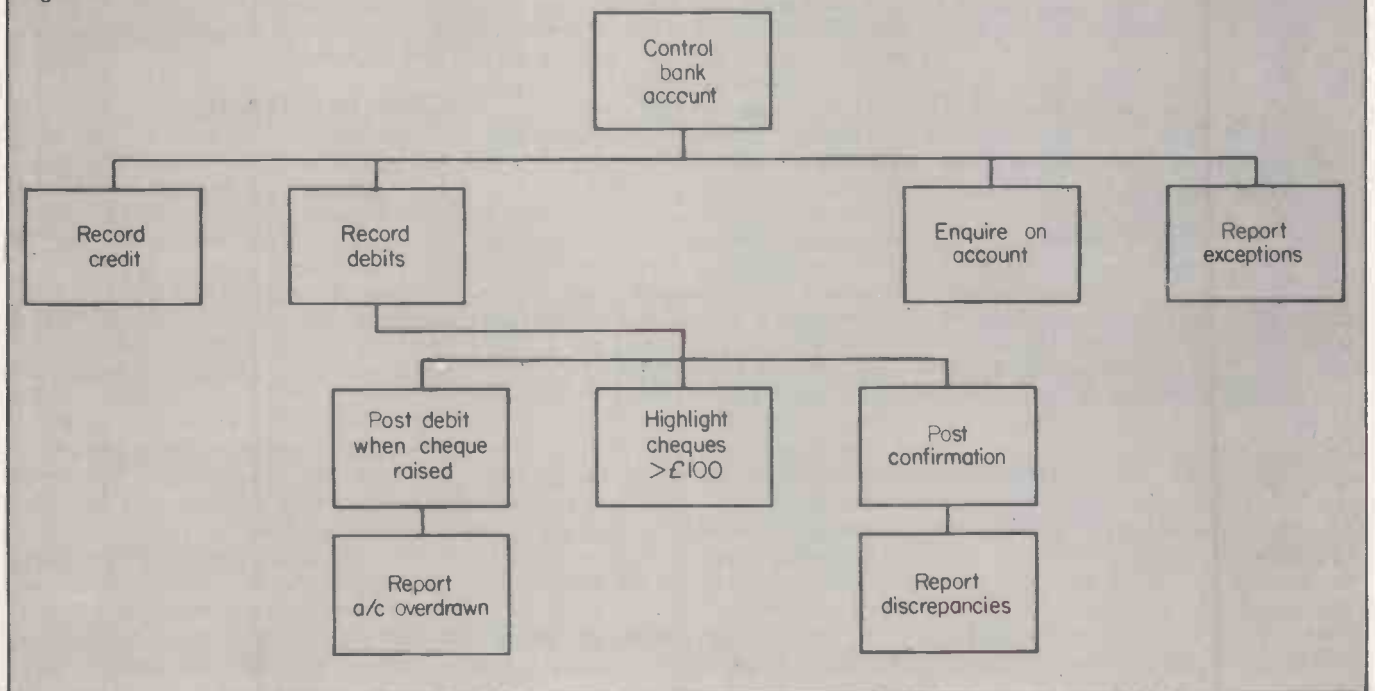

program statements. What is considered to be a small number may vary from person to person, but the important things to remember are that the group of statements or program module should have only one entry and one exit point and that it should be easily understood.

The use of tables can ease subsequent program maintenance greatly as can be shown by considering the calculation of VAT in a business system. One approach to the problem would be to hold the percentage rate against each item on a stock file but that would entail changing each record each time the rate changed.

An alternative is to hold against each item on the stock file a VAT category and to maintain a separate table showing the effective rate for each category — figure 2.

That feature can be used whenever an item held on a file may have only a small number of values, for example weightings applied to certain criteria. The criteria can be identified both on a file and in an associated table while the weightings shown in the table can be varied at will.

## Parameter-driven

Parameter-driven programs are those which include various procedures not all of which are to be used on each run of the program. The procedures to be used being decided upon by inspecting parameters provided either by the person operating

Stock File	
Description	VAT category
Cooker	0
Radio	1
Television recorder	1
Video recorder	3
Washing machine	1
Dishwasher	1

VAT Table		
VAT category	Rate	Rate
	1.6.79	20.3.81
0	0	0
1	15	10
2	15	10
3	15	20

Figure 2.

the program or by other procedures in the program.

An example of this is in a game where the routine to be used on a particular occasion varies to introduce a randomising effect. Each pre-programmed routine will perform the required function but produce differing results. The routine used may be decided on by another program module generating, for example, a random number.

In a business environment, a program which is used every day may need to produce additional information at the end of a month or at the end of the tax year. The user can signify by parameters that today

is a month-end or a year-end and the program will activate the appropriate modules to produce the required information.

That facility is particularly useful in situations where there are known variations in requirements. Each variation can be pre-programmed and the one to be used on each occasion chosen at will.

A final aid to easier program maintenance is good documentation. Even if you are the one who wrote the program and only you are to use it, it is advisable to document the program both by including appropriate comments in the coding and by preparing a separate manual.

This document should both advise on the operation of the program, you may need to refresh your memory if it is not used for some time, the act as a reference manual when you wish to alter something.

We live in a changing world and have changing requirements. Most programs, having been written to satisfy some of those requirements need, therefore, to be flexible in design and adaptable.

## Minimise work

Program maintenance can often be a time-consuming and frustrating task but by utilising some of the design techniques described, it is possible to minimise the amount of effort necessary in undertaking such work. □

## 15 good reasons for visiting Cambridge

1. TRS-80 Model I & II
2. Apple II & III
3. CBM (PET) 3000/8000
4. North-Star Horizon
5. Cromemco
6. Hewlett-Packard HP-85
7. Compukit
8. Sinclair ZX80
9. Acorn Atom
10. Infoton vdu
11. Houston
12. Qume
13. Centronics
14. WordStar

With a uniquely comprehensive selection like this — all generally on demonstration and available from stock with full support by our team of computer professionals — you'll have the ideal chance of finding precisely the right system for your application.

Looking for a microcomputer? — then visit us at:

### Cambridge Computer Store

1 Emmanuel Street Cambridge CB1 1NE  
Telephone: (0223) 65334/68155

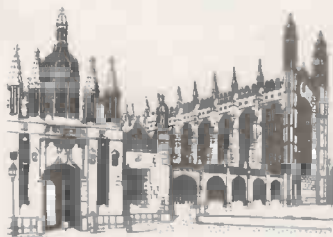

# Microprocessor-controlled model railways

How to interface a zero-gauge model train to a computer which controls the shunting operations of the engine and the marshalling of trucks in and out of sidings. The system is presented by Bob Coats, Alison King and Don Thatcher.

THE LAY-OUT for the railway system is shown in figure 1. It comprises:

Five tracks: a single line, T1, leading to four sidings, T2, T3, T4 and T5. The space available did not permit a passing loop on track as had been planned originally.

Two end-of-track sensors EOT-1 and EOT-2. Three points, P1, P2 and P3 and their associated switching mechanisms.

Four uncouplers, U2, U3, U4 and U5.

Five track-code sensors, S1, S2, S3, S4 and S5.

Suppose trucks 3, 7 and 9 are on track 5, the engine is on track 1 and it is required to form a train comprising the engine followed by trucks 7 and 3. One possible sequence of shunting operations is:

CHANGE points for track 5

drive engine BACKWARDS until coupled on to trucks

LOCATE truck 7 using truck-code sensor 5 moving FORWARDS

UNCOUPLE between trucks 7 and 9

drive engine FORWARDS until on track 1

CHANGE Points for track 4

LOCATE truck 9 using truck-code sensor 4 moving BACKWARDS

UNCOUPLE between truck 9 and engine

drive engine FORWARDS until on track 1

CHANGE points for track 5

drive engine BACKWARDS until coupled on to trucks

drive engine FORWARDS until on track 1

STOP

The following basic operations can be identified from the sequence:

FORWARD and BACKWARDS

STOP

CHANGE POINTS

LOCATE specified truck

UNCOUPLE

SPEED, variable

A diagram of the motor control unit is in figure 7. Applying a logical 1 to input F and a logical 0 to input B will make output X + 15 volts relative to output Y, causing the motor to turn in the forwards direction. The opposite cause of a logical 0 on input F and a logical 1 on input B will cause the motor to turn in the backwards direction. The motor will be stopped if either logical 1s or 0s are applied to both F and B.

The circuit used in the motor control unit was based on one given in an article in *Practical Electronics*, in which the polarity of the power applied to the motor is controlled by a bridge circuit of power transistors. The circuit was modified to prevent the case of a logical 1 applied to both F and B destroying the power transistors.

The speed of the train is controlled by rapidly pulsing the power to the track, varying the ratio of on-time to off-time — the mark-space ratio. This timing is achieved through the software.

The end-of-track sensors consist of light-activated switches on one side of the



A general view of the track.

track illuminated by light from bulbs on the opposite side. The action of the train breaking the beam causes the switch to change. The bulbs are of the type incorporating a focusing lens, to ensure that the intensity of the beam at the light-activated switch is significantly greater than the background light.

Two solenoids, the set solenoid and the re-set solenoid, constitute the switching mechanism of each point. A ferromagnetic core common to both solenoids is attracted towards one

solenoid, say, the set solenoid, when a current is passed through that solenoid, and the movement of the core, via suitable linkage, causes the point to be set. A current through the other solenoid causes the point to switch the other way, i.e., to be re-set.

A diagram of the points-switching unit is shown in figure 2. A particular point is selected by an appropriate pattern of logical 1s or 0s on the three address lines, e.g., 010 selects point 2. The action required — set or re-set — is selected by a 0 on the enable line.

The circuit used in the points-switching unit was based on the circuit given in *Electronics Today International*. A large capacitor — 22,000  $\mu\text{f}$  — is discharged through the appropriate solenoid when the point-switching unit is enabled. The discharge provides adequate initial energy to operate the solenoid, but the available current falls rapidly to a few hundred milliamps as the capacitor discharges, thus eliminating the problem of burnt-out solenoids.

Each solenoid is connected to a power transistor, the switching of which causes the capacitor to discharge through its solenoid. The switching signals are provided by the outputs of a four-line-to-16-line demultiplexor — SN54154; the inputs to the demultiplexor are the three address lines, the set re-set line and the enable line. Only six of the 16 demultiplexor outputs are necessary for the points in this lay-out.

The existing couplings on the trucks and engine were all replaced by a home-made pivoting arm mechanism as shown in figure 3. The uncoupler mechanism consists of an electro-magnet positioned between the rails. When the electro-magnet is activated, and a truck is directly

Figure 1.

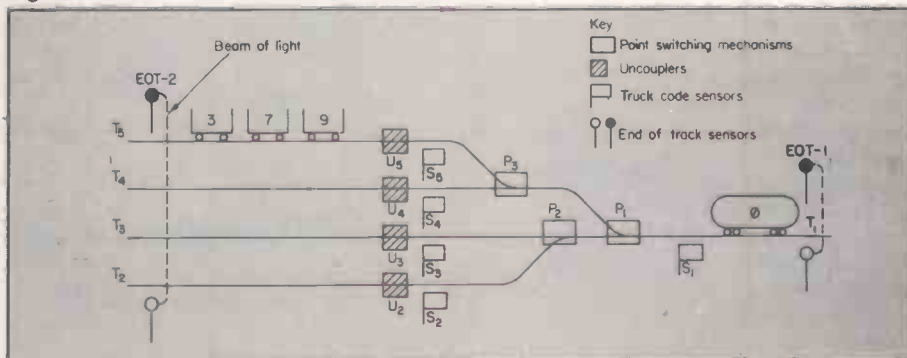

over it, the flat plate attached to the pivoted arm is attracted towards the track, causing the hook at the other end of the arm to lift off the preceding truck, thus uncoupling the two trucks.

Solenoids similar to those used for point switching were used for the uncouplers, and four of the 10 unused demultiplexor outputs of the points Switching Unit were used for activating the uncouplers — SET4 for U2, SET5 for U3, etc.

The status of the points can be sensed using two switches, the SET switch and the RE-SET switch, built into the point switching mechanisms.

Point state	Set switch	Re-set switch
set	closed	open
re-set	open	closed
in-between	open	open

Under normal operation only one switch should be closed. If the point sticks between the set and the re-set states, the set switch and the re-set switch may both be in the open states. Certain faults can also cause both switches to appear closed.

Consequently, to detect faults, it is necessary to monitor the status of both the set switch and the re-set switch.

A multiplexor (SN54151) is able to select one of eight data sources, and switch it to the output line. The set switches are connected to one multiplexor, and the re-set switches are connected to a second one. On selecting a particular point, the status of its set switch is

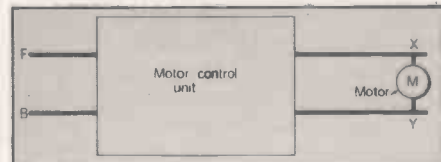

Figure 7.

fed to the computer along the set status line, and the status of its re-set switch is fed along the re-set status line. The circuit for the set case is shown diagrammatically in figure 4. Only three of the eight inputs available are used.

The system caters for one engine and up to 15 trucks; each has an identification code inscribed on a home-made reflective metal plate mounted on its side. The code consists of eight bits; the right-most four bits make up the truck identifier, 0-15, and the left-hand four bits are formed by reflecting the right-hand bits about the central vertical axis of the plate.

Hence, the code appears the same whatever the direction in which the truck passes the sensor. With that scheme, as the truck passes the sensor, the code is in effect read twice as a precaution against misreads. A truck-code sensor and an example truck-code plate are shown in figure 5.

The truck codes are sensed by a cluster of three reflective opto-switches. An opto-switch — Radio Spares 307-913 — comprises an infra-red light-emitting diode and a photodarlington transistor housed

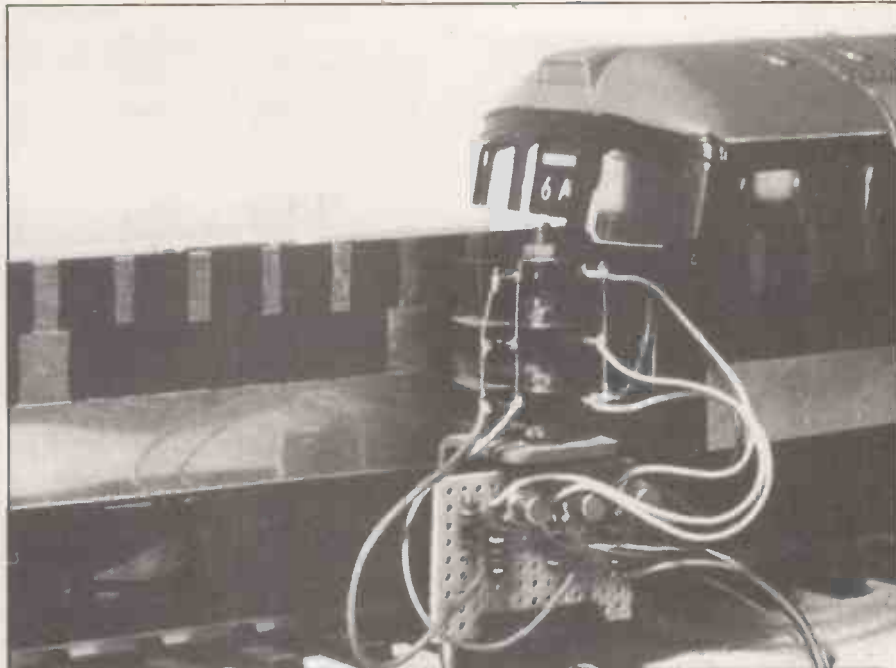

The sensor clusters and coding system of an engine.

in a moulded package. A reflecting surface placed at a distance of between two and 10mm. from the opto-switch will cause the infra-red light to reflect back to the detector. Hence, the presence of the reflecting surface is detected by the opto-switch.

The patterns on the truck-code plate are sensed by the truck-code sensors located by the side of the track as the truck is moved past by the engine. Non-reflecting areas of the plate are painted matt black while reflecting areas are left metallic. A plate is divided into three zones — top, middle and bottom — and each zone has an opto-switch associated with it.

The bottom zone defines the extent of the plate; the data in the top and middle zones will be used only when the bottom zone is reflecting. The top zone comprises eight reflecting markers, to mark the position of the data bits making up the truck code in the middle zone — the condition of the middle zone — reflecting or non-reflecting — is sensed when each marker in the top zone is encountered.

There are three truck-code sensors, each being a cluster of three reflective opto-switches. The top, middle and bottom signals from each cluster feed into three multiplexors, SN54151, in a manner similar to that described in point sensing. The outputs from the multiplexors are the top-status-line, the middle-status-line and the bottom-status-line, which indicate the states of the cluster currently addressed by the address lines.

The control program for the train runs on a Z-2 Cromemco computer, Z-80 with the following boards:

- processor
- 16K random access memory (RAM)
- TUART
- D-A and A-D
- Bytesaver

All the signals — seven input and nine

output — for controlling the train system are digital, either logical 0 or 1 — no analogue signals are used. It was decided to use the D-A and A-D board for the interface — it provides one eight-bit parallel input port and one eight-bit parallel output port as well as seven analogue inputs and seven analogue outputs — and keeps the other ports free for possible extensions to the system. The lines were allocated:

SET	point status line	: Parallel Input 0
RE-SET	point status line	: Parallel Input 1
BOTTOM	truck-code status	: Parallel Input 2
MIDDLE	truck-code status	: Parallel Input 3
TOP	truck-code status	: Parallel Input 4
EOT-1	end-of-track 1	: Analogue Input 1
EOT-2	end-of-track 2	: Analogue Input 2

F	Forwards	: Analogue Output 1
B	Backwards	: Analogue Output 2
A-0	address line 0	: Parallel Output 0

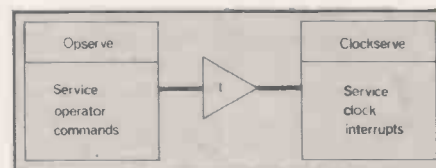

Figure 8.

A-1	address line 1	: Parallel Output 1
A-2	address line 2	: Parallel Output 2
S/R	Set/re-set points	: Parallel Output 3
E-1	Enable point switching/uncoupling	: Parallel Output 4
E-2	Enable point sensing	: Parallel Output 5
E-3	Enable truck-code sensing	: Parallel Output 6

The analogue lines are used as digital lines — either logical 1 or 0. The analogue outputs were used for the direction and speed control simply to keep those functions separate from the functions on the parallel output port.

No serious consideration was given to the optimum use of the available inputs and outputs; indeed, there is intentional redundancy in the system to give future students studying the system as a case

(continued on next page)

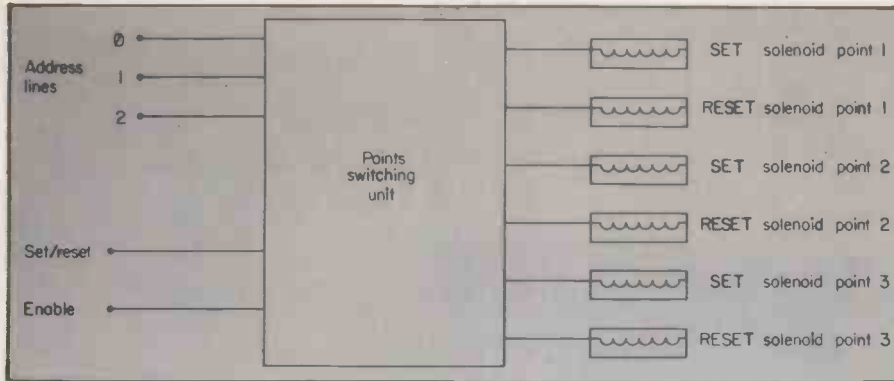

Figure 2.

(continued from previous page)

history scope for criticism and for suggesting improvements.

A variety of techniques for specifying the programs are in use; most of them adopt a structured approach and some graphic aid. The method adopted is a mixture of:

- A network chart and a program-structure chart — as described in the NCC data processing documentation standards, but omitting the NCC filing references — to provide the top level of description.

- Structured English — as described by Parkin in Systems Analysis reference 4 to specify the procedures. The method is particularly easy to modify and maintain. The rules are very simple — the procedure is described in natural language, but the control structures are limited to those compatible with structured programming. The specifications will take the form of sequences of natural constructions or case constructions, under the control of expressions such as while condition; until condition; repeat n times, etc.

- The scope of a control loop or condition is shown by indenting the subordinate statements by a few spaces. At the end of the controlled or conditioned statements, the indentation is dropped. An else is always lined-up with the if or other conditional expression which it matches. Arbitrary subroutines are created, as desired, by the use of underlined phrases.

The network chart shown in figure 8 specifies that there are two processes — Opserve and Clockserve — constituting the train-control program. The function of Opserve is to obtain and validate operator commands, and service them by a call to the appropriate procedure.

The purpose of Clockserve is to monitor periodically the state of the system, and to take any actions necessary. Clockserve is entered whenever an interrupt is generated externally by an interval timer on the Tuart board, which is set to provide an interrupt every millisecond.

Having serviced the interrupt, control is returned to the instruction in Opserve which was about to be executed when the interrupt servicing began.

The process to service clock interrupts, Clockwise:

```

disable interrupts
save registers
if end-of-track 1 is broken and DIRECTION = "F"
    speed = "0" : set motor value
    FORWARD-RESTRICTION = on
    ABORTED = true
if keyboard is ready and character = ESCAPE
    ABORTED = true
if HOLD 0
    decrement HOLD by 1
determine-power
if DIRECTION = "F"
    send power-off-or-on to F (analogue output 1)
    send 0 to B (analogue output 2)
else
    send power-off-or-on to B
    send 0 to F
restore registers
set interrupt interval to 1 msec
enable interrupts

```

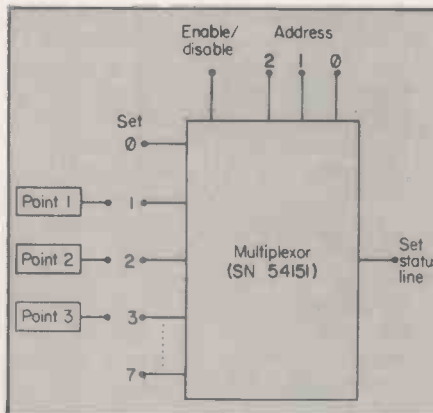

Figure 4.

The primary function of Clockserve is to control the speed of the train. The procedure Determine-Power sets power-off-or-on to 1 if power is due to be applied to the track, and to 0 if not. If power-off-or-on is 1, power is applied in the direction specified by DIRECTION; otherwise no power is applied.

Various methods for determining the value of power-off-or-on can be used, two of which are:

- Each speed is given an eight-bit representation — Speed 1 = 00000111, Speed 2 = 00001111, Speed 3 = 00011111 and Speed 4 = 00111111 — which is stored in Motor. Every time Clockserve is entered, the least signifi-

cant bit of Motor is tested; if it is 1, power is due to be applied to the track and power-off-or-on is set to 1, otherwise power-off-or-on is set to 0. Finally, the bit pattern is rotated one position to the left. Consequently Speed 1 applies power to the track for three out of eight time units, one time unit being one msecond, the interrupt interval.

```

if least-significant bit of MOTOR is 0
    power-off-or-on = 0
else
    power-off-or-on = 1
rotate MOTOR one position to the left

```

- Motor is initialised to 0 in Validate when Speed is set. Each time Clockserve is entered, the following algorithm is applied to determine power-off-or-on:-

```

case: SPEED = "0"
    power-off-or-on = 0
case: SPEED <> "0"
    if MOTOR < SPEED + 2
        power-off-or-on = 1
    else
        power-off-or-on = 0
MOTOR = MOTOR + 1
module 8

```

The structure chart for Opserve in figure 6 shows for each procedure of the process which procedures call or are called by it. There is no indication of the sequence in which the procedures are performed during a run, nor of their relative frequencies of performance.

The root procedure of Opserve is Validate, whose purpose is to validate commands entered by the operator. Each subsequent row of the chart indicates the next lowest level of procedure. For example Change, Uncouple and Locate are all procedures called by Validate.

The validation of operator commands, initialise

```

done = false
repeat until done
    display status information
    get command
    case: ESCAPE
    case: command = "Q" and
        SPEED = "0"
        done = true
    case: command = "F" and FORWARD-RESTRICTION = off
        if DIRECTION = "B" and SPEED <> "0"
            halt the train
            SPEED = old speed :
            MOTOR = old motor
            DIRECTION = "F"
        BACKWARD-RESTRICTION = off
    case: command = "B" and BACKWARD-RESTRICTION = off
        if DIRECTION = "F" and SPEED <> "0"
            halt the train
            SPEED = old speed :
            Motor = old motor
            DIRECTION = "B"
        FORWARD-RESTRICTION = off
    case: command = "0" and SPEED <> "0"
        halt the train

```

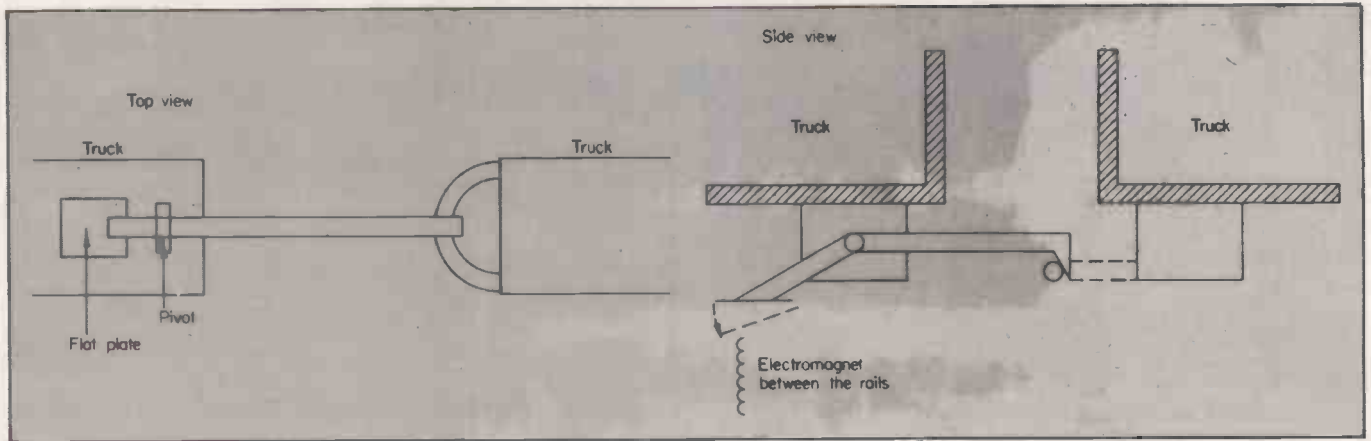

Figure 3.

```

case:command = "1" or "2" or "3" or
"4"
    SPEED = command :
    set MOTOR value
case:command = "C" and SPEED = "0"
    get point-number (p)
    case:ESCAPE
    case:valid point-number
    (1 <= p <= 3)
    change point p
case:anything else
    ring bell : output
    "invalid point number"
case:command = "U" and SPEED = "0"
    get uncoupler-number (u)
    case:ESCAPE
    case:valid uncoupler-number
    (2 <= u <= 5)
    uncouple using uncoupler u
case:anything else
    ring bell : output "invalid
    uncoupler number"
case:: command = "L" and
    SPEED = "0"
    get truck-number (t)
    case:ESCAPE
    case valid truck-number
    (0 <= t <= 15)
    get truck-code sensor
    number (s)
    case: ESCAPE
    valid truck-code sensor number
    (1 <= s <= 5)
    get direction (d)
    case:ESCAPE
    case:valid direction
    ("F" or "B")
    DIRECTION = d
    SPEED = "1" :
    set MOTOR value
    locate truck t
    using sensor s
    anything else
    
```

The uncoupling mechanism.



```

ring bell :
    output
    "invalid direction"
case:anything else
    ring bell :
    output
    "invalid truck-code
    sensor no"
case:anything else
    ring bell :
    output
    "invalid truck number"
case:anything else
    ring bell : output
    "invalid command"
output termination message : stop
    
```

The purpose of Validate is to check the commands entered by the operator, and to sound the bell and output an appropriate message if any are invalid. The syntax of the instruction repertoire is:

```

Q           : Quit
F or B     : Direction
O or 1 or 2 or
3 or 4     : Speed
C p        : Change point
            p(1 <= p <= 3)
U u        : Uncouple with
            u (2 <= u <= 5)
L t s d    : Locate truck
            t:(0 <= t <= 15)
            using sensor
            s (1 = s = 5)
            in direction
            d (F or B)
    
```

The specification of Validate should be more or less self-explanatory. The underlined phrases — initialise, display, halt, change, uncouple and locate — are flower-level procedures, as shown in the structure chart for Opserve — figure 6.

Case:Escape means the Escape key was pressed by the operator in response to the last prompt for input. The effect is for the computer to re-display the status informa-

tion and prompt the operator for another command, ignoring anything entered by the operator prior to the Escape. That is represented in Validate by there being no indented statements subordinate to this case.

The operations Quit, Change point, Uncouple and Locate are acceptable only if the train is stationary. In the specifications following:

activate : means sending the appropriate bit pattern for the particular function to the parallel output port for example, to activate truck-code sensor 3 for a Locate operation, the following bit pattern would be sent:

```

0 A-0 1)
1 A-1 1) Address value 3 (011)
2 A-2 0)
3 S/R 1 not used
4 E-1 1 disable point switching
5 E-2 1 disable point sensing
6 E-3 0 enable truck-code sensing
    
```

de-activate : means sending a bit pattern to disable the function, e.g., in the above example 1111011 would be sent, disabling truck-code sensing, E-3.

To ensure that point p is in a valid state, "R" or "S", Ensure-Point:

```

repeat until point-status "X"
    sense point p
    if point-status = "X"
        output "manual correction required"
        wait for operator
    
```

To sense the state of point p, Sense:

```

activate sensing of point p
case:set-status-line = 1 and
re-set-status-line = 0
point-status = "S" i.e., set
case:set-status-line = 0 and
re-set-status-line = 1
point-status = "R" i.e., re-set
case:any other combination
point-status = "X" i.e., faulty state
de-activate sensing of point p
    
```

To initialise the system, initialise:

```

DIRECTION = "F" : SPEED = "0" :
set MOTOR
FORWARD-RESTRICTION = off :
BACKWARD-RESTRICTION = off
HOLD = 0 : ABORTED = false
prepare for interrupts
set interrupt interval to one msec
enable interrupts
    
```

To display system status information on the screen, display:

(continued on page 97)

# Apple Price List

Product Code	Description	Price (£)
<b>HARDWARE</b>		
A2S1016P	APPLE 16K VIDEO OUTPUT ONLY	695.00
A2M0003	DISC DRIVE WITHOUT CONTROLLER	299.00
A2M0004	DISC DRIVE WITH CONTROLLER	349.00
A2M0016	16K ADD ON RAM	69.00
<b>CARDS &amp; ACCESSORIES</b>		
A2B0001	PROTOTYPE/HOBBY CARD	15.00
A2B0002	PARALLEL PRINTER INTERFACE CARD	104.00
A2B0003	COMMUNICATIONS CARD	130.00
A2B0005	HIGH SPEED SERIAL INTERFACE CARD	113.00
A2B0006	PASCAL LANGUAGE SYSTEM	299.00
A2B0007	CENTRONICS CARD	130.00
A2B0009	APPLESOFT FIRMWARE CARD	116.00
A2B0010	INTEGER CARD	116.00
MHP-X003	MOUNTAIN HARDWARE CLOCK/CALENDAR CARD	160.00
MHP-X006	MOUNTAIN HARDWARE SUPERTALKER	171.00
MHP-X007	MOUNTAIN HARDWARE ROM PLUS BOARD	116.00
MHP-X015	MOUNTAIN HARDWARE ROMWRITER	101.00
E2B100	EUROCOLOUR CARD	79.00
E2B101	APPLE BLACK & WHITE MODULATOR	14.00
E2B102	A1-02 DATA ACQUISITION CARD	180.00
10-5-16	ALF MUSIC SYNTHESIZER CARD	142.00
10-5-17	ALF TIMING MODE INPUT BOARD	14.00
13-3-2	ALF ALBUM MUSIC DISKETTE NUMBER ONE	12.00
13-3-4	ALF ALBUM MUSIC DISKETTE NUMBER TWO	12.00
13-5-5	ALF ALBUM MUSIC DISKETTE CHRISTMAS	12.00
A2M0015	HEURISTICS SPEECH LAB	122.00
A2M0019	PROGRAMMERS AID 1	27.00
A2M0027	AUTO START ROM PACK	38.00
A2M0029	GRAPHICS TABLET	462.00
E2B104	HEURISTICS CONTROLLER 70	52.00
E2B105	HEURISTICS SPEECHLINK 2000	160.00
E2B107	IEEE INTERFACE	212.00
<b>SOFTWARE</b>		
A2D0005	CONTRIBUTED SOFTWARE VOL3 3-5	60.00
A2D0006	CONTRIBUTED SOFTWARE VOL3 1-2	27.00
A2D0009	MICROCHESS 2.0 CHESS DISK	15.00
A2D0010	DISC UTILITY PACK	15.00
A2D0012	APPLE BUSINESS CONTROLLER PROGRAM	340.00
A2D0013	APPLE POST PROGRAM	27.00
A2D0018	APPLE BOWLING DISCETTE	9.00
A2D0025	APPLE CASHIER PROGRAM	194.00
A2D0026	APPLE WORD PROCESSING PROGRAM	42.00
A2T0013	MICROCHESS 2.0 CHESS CASSETTE	15.00
E2D001	VISICALC DISC & BOOK COMPLETE	95.00

Product Code	Description	Price (£)
<b>DOCUMENTATION</b>		
A2L001A	APPLE II REFERENCE MANUAL	11.00
A2L0002	6502 HARDWARE MANUAL	9.00
A2L0003	6502 SOFTWARE MANUAL	9.00
A2L0005	APPLE II BASIC PROGRAM MANUAL	6.00
A2L0006	APPLE II REFERENCE MANUAL	6.00
A2L0012	DOS 3.2 MANUAL	6.00
A2L0018	APPLE II BASIC TUTORIAL MANUAL	6.00
<b>GENERAL ACCESSORIES</b>		
A2D0000	(10) BLANK APPLE DISCETTES	32.40
A2M0009	VINYL CARRYING CASE	16.00
AD/LB	MINI DISC LIBRARY BOX	2.64
MD5172	DISCOFLEX FILING CASE—MINI	12.64
APP1	APPLE DESK TWO TIER	145.00
APP2	PRINTER TABLE	92.00
APPLETEL	APPLETEL SYSTEM	595.00
DUST/APP	DUSTCOVER FOR APPLE II	5.35
E2B013	APPLEJUICE RESERVE POWER SUPPLY	148.00
<b>PRINTERS &amp; ACCESSORIES</b>		
A2M0034	SILENTYPE 80 COLUMN GRAPHICS PRINTER	349.00
A2C0001	10 ROLLS OF THERMAL PAPER FOR SILENTYPE PRINTER	28.00
HUSH100/A	MICROHUSH 100 PRINTER C/W APPLE INTERFACE	266.00
HUSHPAP	16 ROLLS THERMAL PAPER 80FT LONG	22.00
HUSHPAP/E	2 ROLLS THERMAL PAPER 80FT LONG	5.00
TIGER/G	PAPER TIGER PRINTER WITH GRAPHICS OPTION	598.00
TIGER/C	CONNECTOR CABLE FOR TIGER PRINTER	9.00
TIGER/D	GRAPHICS SOFTWARE FOR TIGER PRINTER	20.00
TIGER/P	TIGER PAPER 2,000 SHEETS 11" x 9 1/2" S/PART	35.92
TI810	TEXAS OMNI 810 PRINTER	1450.00
LP5	PAPER 2000 SHEETS 11" x 15" S/PART	14.06
LP9	PAPER 3000 SHEETS 8" x 12" S/PART	14.85
<b>VIDEO MONITORS</b>		
VM129	12" BLACK AND WHITE VIDEO MONITOR	189.00
VM910	9" BLACK AND WHITE VIDEO MONITOR	127.00
VM906	9" HIGH RESOLUTION BLACK AND WHITE VIDEO MONITOR	148.00
VMC	CABLE FOR VIDEO MONITOR	9.00

Prices exclusive of carriage and VAT and are correct at time of going to press. Available from Apple Dealers all over the UK—for your nearest please contact Microsense Computers.

Dealer/OEM enquiries welcome.

## microsense computers limited

Finway Road, Hemel Hempstead, Herts HP2 7PS  
Tel (0442) 48151 and 41191  
Telex: 825554 DATEFF G

SOLE UK DISTRIBUTOR  
**apple computer**

Apple is a trade mark of Apple Computer Inc., Cupertino, C.A., USA

Circle No. 172





(continued from page 95)

show DIRECTION and SPEED on screen for all points  
ensure-point is in valid state  
show point state on the screen, i.e., "R" or "S"

show end-of-track sensor states on the screen

To halt the train, Halt:

SPEED = "0" : set MOTOR value  
delay or 250 mseconds to allow train to stop

To change point p, Change:

ensure-point p is in a valid state  
if point-status = "S"  
  required-operation = "R"  
else  
  required-operation = "S"  
attempt = 1  
done = false  
repeat until done  
  if attempt <= 3  
    activate point p for required-operation  
    delay for 50 mseconds to allow point to switch  
    de-activate point p  
    delay for 250 mseconds to allow capacitor to re-charge  
    attempt = attempt + 1  
  else  
    output "manual correction required"  
    wait for operator  
    sense point p  
    if point-status = required-operation  
      operation  
      done = true

Change will make three attempts to change the point to the requested state; if it fails, manual correction will be requested.

To uncouple using uncoupler u, Uncouple

activate uncoupler u  
delay for 225 mseconds to allow magnetic field to build-up  
SPEED = "4" : set MOTOR  
delay for 225 mseconds to allow train to move approximately 10 cm.  
de-activate uncoupler u  
halt the train

delay for 750 mseconds to allow capacitor to re-charge

To locate truck t using sensor s, Locate:

found = false  
ABORTED = false  
make up requested-code from truck number t  
activate truck-code sensor s  
repeat until found or ABORTED

wait until ABORTED or bottom = 1  
repeat until ABORTED or bottom = 0  
wait until ABORTED or top = 1  
if not ABORTED  
  read middle  
  build-up detected-code  
  wait until ABORTED or top = 0  
if requested-code = detected-code  
  output 'truck found'  
  halt the train  
  found = true  
de-activate truck-code sensor s  
if not found  
  output 'truck not found'

The logic of Locate is basically while bottom = 1, each time top changes to 1, read middle and build up detected-code.

Searching for the requested-code will continue until either the code is found or the search is terminated by Clockserve setting aborted because the operator pressed the escape key, the train broke an end-of-track sensor. Requested-code for truck 5 for example is 1010 0101.

Locate is designed to detect the eight-bit palendromic truck-codes which it does very effectively — the failure rate is less than one percent. As a consequence of searching for well-defined patterns, spurious reflections are easily recognised and rejected.

The optimum value of 1 msecond for the interrupt interval was determined experimentally. Making the interval too large causes the train to move in fits and starts, while making it much less than 1 msecond causes the motor not to turn, because of the increased reactance.

The particular eight-bit speed patterns were also determined experimentally. In principle, eight speeds are possible, but in practice, the patterns 01111111 and 11111111 cause the train to go too fast for the size of the lay-out, while the train would scarcely move with the patterns 00000001 and 00000011. The maximum speed of the train was 85 cm./second.

There is a single capacitor common to all points and uncouplers. A point is switched by discharging this capacitor through one of the two solenoids of the point switching mechanism. It is not necessary to discharge the capacitor completely; the discharge can be initiated by setting the enable line of the points-switching unit to 0, and terminated at some later time by re-setting the enable

line to 1 when the point has switched.

The minimum time interval consistent with the points switching reliably was found to be 50 mseconds. After the discharge, the capacitor needs to re-charge before an attempt is made to switch another point. The re-charge time was 250 mseconds, hence the delay times used in the procedure Change.

In the case of the uncouplers, the discharge was allowed to proceed for a longer time so that a sufficiently strong magnetic field could be generated to attract the plate on the underside of the truck, and to hold it while the train moved forward. The discharge time was 250 mseconds with a correspondingly longer re-charge time.

One problem encountered with the reflective opto-switches was that during the transition from non-reflecting to reflecting, or vice-versa, the output from the switch was unstable, and gave rise to spurious data. The solution was to wait for about 150  $\mu$ seconds — to allow for the rise-time of the switch — and then re-sample the signal; only if the two samples agreed was the change accepted.

That delay, together with the delay inherent in processing an interrupt, provided the potential for another problem. Suppose one reflecting marker in the top zone of the truck-code plate has just entered the field of view of its opto-switch, causing the switch to change. That change will be detected in the software, and the 150  $\mu$ seconds' delay described will be initiated, to allow the signal to stabilise.

Just prior to the end of this delay, suppose an interrupt occurs. The maximum execution time for the instructions comprising the interrupt handler is 110  $\mu$ seconds. Hence the total time between first detecting the change, and then confirming it, could be as large as 260  $\mu$ seconds. In the meantime the truck is moving past the sensor, at a maximum speed of 85 cm./second.

The maximum distance the plate could move in this time is .22 mm.; hence the widths of the reflecting markers need to be larger than .22 mm. In practice, the narrowest reflector was two mm.

The end-of-track sensors were positioned sufficiently distant from the end of the track so that even if the train was travelling at full speed when it passed the sensor, its momentum would not carry it beyond the end of the track.

The uncouplers were positioned close to the truck-code sensors so that when a particular truck had been located by a sensor, the plate on its underside was positioned above the associated uncoupler. The precise stopping position depends on:

- The speed of the train, because of the extra stopping distance at higher speeds. Consequently, the Locate command operated at a fixed speed.
- The length of the train, because of the

Figure 5.

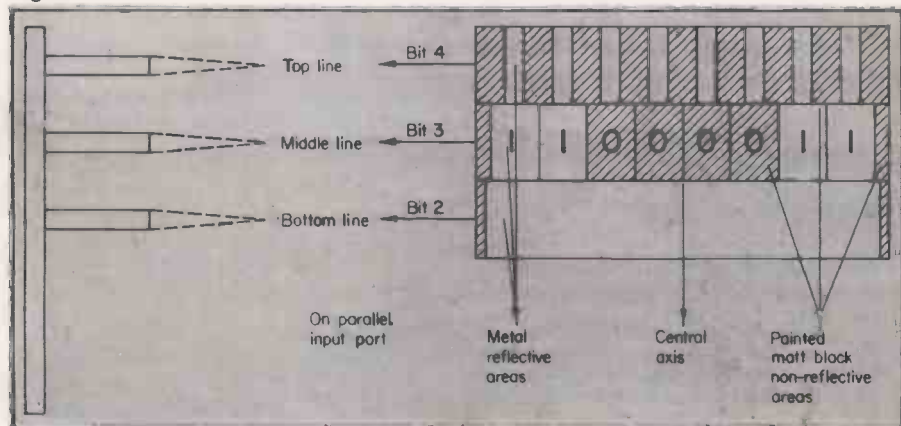

(continued on page 99)

# Why not the best?



great  
programs from

Petsoft and  
Appleware

ACT Microsoft bring you America's best — programs for your PET or Apple by Personal Software Inc. Programs like VISICALC II, the latest version of the award winning problem-solving software that handles mathematical and financial forecasting — and solves just about any problem that can be represented in tabular form, (£125)

GAMMON GAMBLER is an exciting new backgammon program which lets you play the computer. Watch out also for CHECKER KING — it plays a mean game of draughts! And then there is MICROCHESS, the world's best-selling

computer chess program. Need we say more? *All the above cost £14 on cassette for PET or £17.50 on disk for Apple.*

CCA DATA MANAGEMENT SYSTEM is a superb new database program that turns your Apple into an electronic filing cabinet. You will find it surprisingly easy to store, sort and update every kind of information. *The price is £75.*

They call DESKTOP PLANNER the 'businessman's friend'. And no wonder; it brings real computing power to your fingertips for just £75 (*Apple only*).

For more information about this exciting software, send today for your copy of the ACT Microsoft catalogue — it is FREE !

# ACT MICROSOFT

Radclyffe House, 66/68 Hagley Road, Edgbaston,  
Birmingham B16 8PF. Tel. 021-455-8585  
Telex 339396

PET is the trademark of Commodore Systems. Apple is the trademark of Apple Computers.

Prices exclude VAT and were correct at time of going to press.

NAME \_\_\_\_\_

ADDRESS \_\_\_\_\_

\_\_\_\_\_

POSTCODE \_\_\_\_\_

I have a PET / APPLE / NEITHER (Please delete) PC11



• Circle No. 173

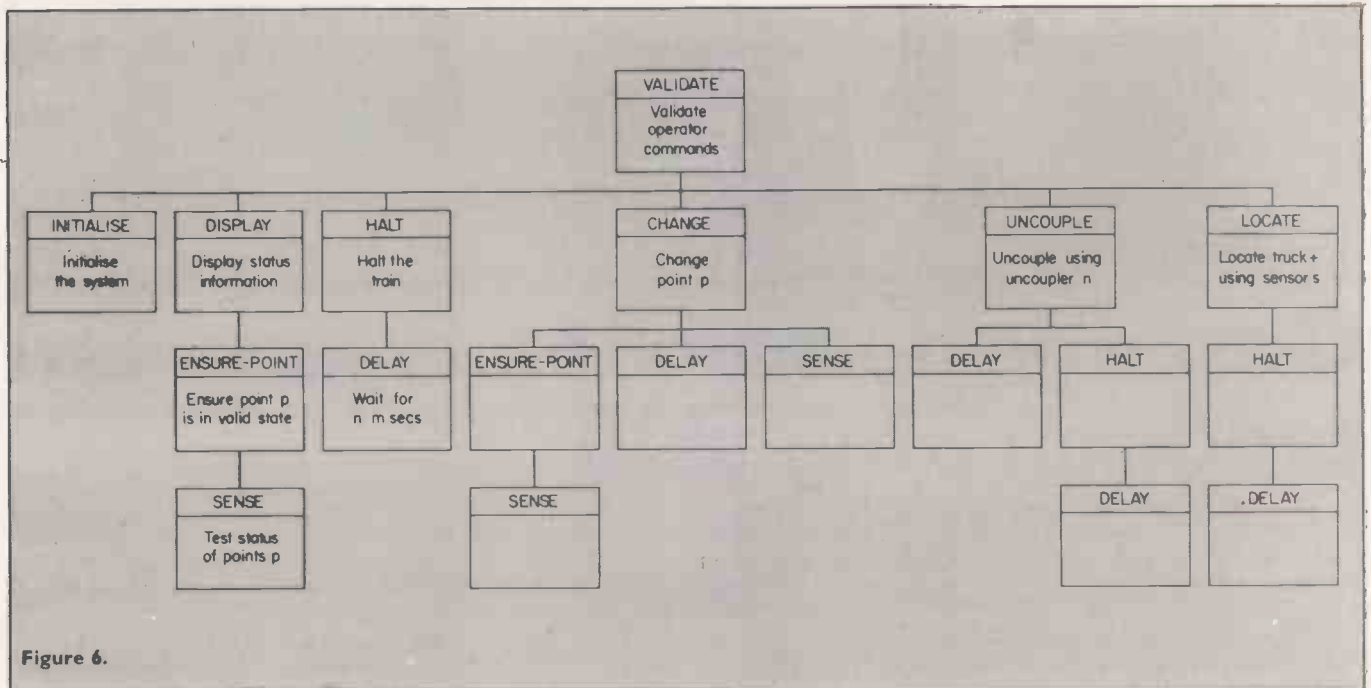

Figure 6.

(continued from page 97)

slack in the couplings. A truck at the end of a long train will stop somewhat further from the sensor than one near the engine, because of the slack being taken up in each of the couplings contributes more in the former case. The effect was overcome by reducing the slack in the couplings themselves, and by making the plate underneath the trucks long enough to cover these variations.

A working system has been implemented; it allows the basic operations listed to be controlled by an operator via the computer. In this minimum system, certain situations are left to the good sense of the operator, for example, checking whether the train is standing on a point before requesting the point be changed.

The programs, written in Z-80 assembly language, were developed on a Zilog MCZ-20 computer, and the object code was loaded from disc into the memory of the Cromemco Z-2 computer by a loader program residing in the Z-2. That method was adopted because the Z-2 lacked disc storage.

Using structured English, one can start off at a high level using general English, identifying what needs doing; gradually expanding and adding more detail one ends at a lower level with a specification of how to achieve the requirements, in sufficient detail to be implementable on a computer.

It assists the designer in the development process in that he can express his ideas in whatever level of detail is appropriate, while allowing him to change his ideas easily.

The specification of the train-control program is independent of the language in which the programs will be written. Obviously, the specification lends itself more

readily to being implemented in a structured language such as Pascal; however, with little more effort in translation, the programs can be written in Basic or assembly language.

Indeed, the programs for the train system were written in assembly language.

Global variables	
Speed	:A speed between "1" and "4" (1 = slowest, 4 = fastest) or 0 = stopped. Set in Validate.
Motor	:holds information used by clockserve to determine whether the motor should be on or off during the next millisecond interval. Set in Validate.
Direction	: "F" = Forwards or "B" = Backwards. Set in Validate.
Forward-Restriction	: Set to on in Clockserve when the train breaks end-of-track sensor 1 (EOT-1); the train may now only travel backwards until the restriction has been cleared to off in Validate.
Backward-Restriction	: Set to on in Clockserve when the train breaks end-of-track sensor 2 (EOT-2); the train may now only travel forwards until the restriction has been cleared to off in Validate.
Hold	: contains the number of milliseconds which must elapse before some operation may proceed. It is decremented by one every millisecond in Clockserve until it reaches a value of 0. In effect, it provides a delay mechanism, e.g. delay for 50 msecs would invoke the procedure Delay, defined as: Set Hold to required delay (50) wait until Hold = 0
Aborted	: A logical variable used to indicate that the Locate operation currently being undertaken should be discontinued. The reasons may be: 1. The operator has pressed the ESCAPE key 2. The train has broken an end-of-track sensor Set to true in Clockserve; initialised to false and tested in Locate.

Furthermore, one of the authors, who had not been involved with the design and the implementation of the software, developed a Basic program from the specifications.

- A network chart and a program-structure chart — as described in the NCC data processing documentation standards, but omitting the NCC filing references — to provide the top level of description.

- Structured English — as described by Parkin in Systems Analysis to specify the Procedures. The method is particularly easy to modify and maintain. The rules are very simple — the procedure is described in natural language, but the control structures are limited to those compatible with structured programming. The specifications will take the form of sequences of natural constructions or case constructions, under the control of expressions such as while condition; until condition; repeat n times, etc.

- The scope of a control loop or condition is shown by indenting the subordinate statements by a few spaces. At the end of the controlled or conditioned statements, the indentation is dropped. An else is always lined-up with the if or other conditional expression which it matches. Arbitrary subroutines are created, as desired, by the use of underlined phrases.

## References

- Micro drives a train, *Practical Electronics*, August 1979, 42-43
- Model train control system, *Electronics Today International*, November 1979, 42-56
- Data Processing Documentation Standards, NCC, June 1977
- Systems Analysis, Andrew Parkin. Edward Arnold, 1980

The adage, garbage in, garbage out, is only too true. Garbage prevention and destruction are essential skills of the good programmer. In this article, A Sandison describes some of the techniques he has devised which can save a good deal of programming time.

## Garbage destruction is essential programming skill

SILLY RESULTS give computerised operations a bad name and arise partly from the programs and partly from the data on which they work. Garbage produced during program development reveals the bugs which take a good deal of time to remove.

Two errors which I have now learned to look for relate to those ephemeral variables used as temporary flags of interest only within a few lines of the program.

### Unexpected results

Failure to empty them after use can produce unexpected results when they are next re-used. It is now almost automatic for me to write 'Z\$ = ""':INPUT Z\$': this copes with pressing the return key without an input.

The other associated fault is to forget that the same variable is being used ephemerally both in the main program and in a subroutine within it. Each works well in isolation, but they produce garbage when combined. I usually use Z for ephemerals; converting the Zs in one routine to Zls will often remove a bug.

Program errors more likely to find their way through into the final stages arise when variables have unexpected values, like 0 or -1. It is the failure of a program to provide for zero values which produces the final demands asking for payment £0,000.0 within seven days.

String handling programs crash with a syntax error if you ask for LEFT\$(A\$, -3). If your Basic has a MAX(,) instruction, this can be prevented by writing LEFT\$(A\$, MAX(0, Z)). If not, check carefully all the IF statements in the calculation of that Z to make sure that you have provided one 'IF Z 0 THEN ...'.

### Wise procedure

That special check of all the IFs for unexpected values is, of course, always a wise procedure during program development.

It is the elimination of garbage from data with which I am really concerned. Keying errors during data entry are so numerous that it is asking for trouble not

to include checking routines in any program of any importance. If you do not believe that, count the number of times you use the backspace key, which is the first such precaution.

### Useful interval

For extensive data entry, it is wise to allow an interval between the original entry and the check, so that the eye can forget how it misread the handwriting last time. I, therefore, display data in suitable batches, either from arrays in RAM or by recall from disc or tape. Arrays can be easily displayed and faulty lines re-written:

```
200 REM Array validation
210 FOR I = 1 TO N
220 PRINT "Item No. "; I, " — "; A(I)
230 NEXT I
240 INPUT "ENTER Line No. for correction
or '0'"; Z
250 IF Z = 0 RETURN
260 IF Z > N OR Z < 0 PRINT "ERROR. —
Re—"; GOTO 240
270 INPUT "ENTER Correct Value "; A(Z)
GOTO 210
```

### Multiple statements

This program is, for brevity, written with multiple statements on one line, separated by colons, and with IF OR THEN statements. If your dialect does not permit these, translation should not be difficult.

An alternative, and often safer, approach is to re-enter the data and to let the computer check that it agrees with the first version, as:

```
300 REM Data array Re-entry validation
310 PRINT "Re-enter the data item by item,
for validation"
320 FOR I = 1 TO N
330 PRINT "Enter Item "; I, " — "; INPUT Z
340 IF Z = A(I) THEN 400
350 PRINT "It was "; A(I), " last time ";
360 INPUT "RE-ENTER Correct value "; Y
370 IF Y = A(I) THEN 400
380 A(I) = Y: IF Y = Z THEN 400
390 PRINT "That was different from both":
GOTO 360
400 NEXT I
410 PRINT "All data has now been entered
twice as the same value": RETURN
420 RETURN
```

Both those routines work equally well

with string variables as with numeric data, but it can be tedious to re-type a long line just to correct one letter. Routines to re-type only the wrong ones and their replacement are straightforward. They are written most easily if your Basic has a string search command, such as the INDEX (A\$, B\$) of Micropolis Basic and POS (A\$, B\$) of Cromemco 16K Basic.

### First character

They search A\$ and return the position of the first character of B\$, if it is there, or zero if it is not. Using index, a routine to replace X\$ by Y\$ is:

```
500 REM String editing
510 PRINT A$
520 INPUT "ENTER the 'Wrong' characters
or '0' if all OK "; VS
530 IF VS = "0" RETURN
540 Q = INDEX (A$, VS)
550 IF Q = 0 GOTO 590
560 INPUT "ENTER the Replacement
characters "; WS
570 A$ = LEFT$(A$, Q-1) + WS + MID$(A$,
Q + LEN(VS), 250)
580 GOTO 510
590 PRINT: PRINT " 'Wrong' chctrs NOT
present. RE—"; GOTO 520
```

This routine, of course, finds and replaces the first occurrence of the wrong characters, sometimes with unexpected results if you meant to replace the second. That is why it loops back to display the corrected string. Thus attempting to replace "to" by "too" in the sentence, the total is to high, will produce, the total is to high.

If forewarned, it can be avoided by lengthening the string to be replaced until it is unique in the sentence, as "to" or "to". I have one file of several thousand figures some bits of which are many of zeros.

### Validation routines

Despite validation routines, I occasionally realised that I had passed and filed as correct a line which was not. The file records included some unnecessary but easily-recognised identification characters and I applied an editing program to the file on disc. To change the 20th zero in one record, it was necessary to change the

first 19 to X, the 20th to 7, and then change the 19 Xs back to zero.

## Replacement string

By modifying the editing routine, it can replace all occurrences of the wrong string, but it is necessary to guard against the loop re-cycling indefinitely if the replacement string should contain the wrong string, as in changing "to" to "too", or attempting to replace one space after each full stop by two. The following routine will avoid that:

```
600 REM Global string replacement
610 INPUT "ENTER the 'Wrong' characters ";X$
620 X=LEN(X$)
630 INPUT "ENTER the Replacement characters ";Y$
640 INPUT "To replace ALL or SOME occurrences, ENTER 'A' or 'S' ";R$
650 IF R$ <> "A" AND R$ <> "S" PRINT:PRINT "ERROR":GOTO 640
660 REM Obtain here the lines for checking
670 GOSUB 690
680 RETURN
690 B$=A$:A$="":A=0
700 Q=INDEX(B$,X$)
710 IF R$="S" THEN 790
720 IF Q=0 A$=A$+B$:GOTO 770
730 A=1:REM Flag that line changed
740 A$=A$+LEFT$(B$,Q-1)+Y$
750 B$=MID$(B$,Q+X,250)
760 GOTO 700
770 IF A=0 PRINT X$;" not present":RETURN
780 PRINT " ";X$;" replaced by ";Y$;" ";RETURN
790 IF Q=0 A$=A$+B$:GOSUB 510:GOTO 870
```

```
800 A$=A$+LEFT$(B$,Q-1)
810 B$=MID$(B$,Q+X,250)
820 PRINT A$:PRINT TAB LEN(A$)+1;X$:PRINT TAB LEN(A$)+X+1;B$
830 INPUT "Replace or Not: ENTER 'Y' or 'N' ";Z$
840 IF Z$ <> "Y" AND Z$ <> "N" PRINT:PRINT "ERROR":GOTO 830
850 IF Z$="Y" A$=A$+Y$:GOTO 700
860 A$=A$+X$:GOTO 700
870 RETURN
```

That builds a new version of A\$ from the parts which have been checked and then checks the remainder left in B\$. Line 800 displays the faulty characters on a separate line from the rest of the sentence so that there can be no doubt which parts are suspect.

Lines 750 and 760 report on the examination of each line as to whether it was clear or that X\$ is now Y\$. That eliminates those anxious minutes watching an inactive screen wondering whether the program is working properly. Yet, more important, it has enabled me to spot that unintentional changes were occurring because more lines were being altered than I expected.

## Index function

If your Basic dialect lacks the equivalent of the index function, the procedure is still possible, but more tedious. Replace lines 540 or 700 by the following subroutine:

```
800 REM Substring replacement
810 Z=LEN(X$)
```

```
820 Q=1
830 Z$=MID$(A$,Q,Z)
840 IF Z$=X$ RETURN:REM Q is now the position of X$
850 Q=Q+1:IF 1<=LEN(A$)-Z THEN 830
860 Q=0:RETURN
```

Routines of this kind lie at the heart of most text editing programs. Unfortunately, word-processing packages tend to have their own file structures not easily amenable to processing by programs in Basic. For that reason, a text editing program in Basic is worth developing.

## Automatic correction

My own, written in Micropolis Basic, I find quite invaluable for checking correcting and updating files on disc, whether numerical or textual. One application which I have incorporated into my document-writing program is the automatic correction of my favourite spelling mistakes.

I am surprised that a facility for doing that is not incorporated into word-processing packages.

Some Basics, e.g., North Star, use substring instructions which look like arrays, so that B\$(1,5) is the equivalent of LEFT\$(B\$,5) — see line 740 — and B\$(5) is the equivalent of RIGHT\$(B\$,LEN(B\$)-4) or the MID\$(B\$,5,250) in Micropolis Basic as used in line 810. Once again, translation of my routines into other dialects should not be difficult.



# L&J COMPUTERS

3 CRUNDALE AVENUE, KINGSBURY NW9 9PJ 01-204 7525  
THE "PET" SPECIALISTS



## NEW LOW, LOW, 'PET' PRICES!!

Pet 8K (Large keys)	£420*
16K	£499*
32K	£630*
Ext cassette decks (+ counter)	£ 55*
PET Friction Feed printers	£350*
AVAILABLE FROM STOCK	+ VAT
Printers/Disc Drives	Sundries
PET 3023	Compu 3040
PET 3022	Compu 400K
Centronic 779	Compu 800K
Spinwriter	Interfaces

**TRY US!  
YOU WILL NOT BE  
DISAPPOINTED**

SUPERPETS NOW EX-STOCK!

Tool kits: library cases  
Disks: C12 Cassettes  
Paper (roll & tractor feed)  
Labels: Dust covers

### SPECIALS FOR THIS MONTH:

PETMASTER SUPERCHIPS — UPGRADE YOUR PET EVEN MORE!

A FEW ONLY: Brand New CENTRONIC 779 t/f printers £590\*  
Brand New PET 2023 f/f printers £320\*

### THE "MUPETS" ARE HERE!

3 TO 8 PETs ONLY NEED 1 DISK DRIVE...

Daily demonstrations: Ring for details.



COMPLETE SYSTEMS  
FROM £1700!!

THE SYSTEMS WE SUPPLY & INSTALL ARE COMPLETE:  
ESTIMATES GIVEN FREE WITH NO HIDDEN EXTRAS:  
FULL BACK-UP: GUARANTEED EXPERTISE.

\* PRICES DO NOT INCLUDE VAT

PERSONAL SHOPPERS WELCOME  
Phone & Mail Orders accepted.

## SOFTWARE

As well as a full range of Petsoft and Commodore Software, we have some highly reliable "Home-Brewed" programs available.

STOCK CONTROL & INVOICING (Handles up to 500 items — 32K) (180 on 16K). Stock depleted on invoicing, search etc. Cassette, disk (& print option).	£60
CASH BOOK Enter daily/weekly amounts — printout and totals, weekly/monthly analysis, totals and balances.	£90
MACHINE HIRE Typewriter & Plant Hire Firms.	£420
STOCK TAKING Cuts out all the hard work	£230
OUTSIDE SERVICES (For Mini-Cabs Etc)	£220

Sae for free software booklet

Specialists in: Commodore Business Programs  
Bristol Trader, Item & Monitor  
Superpay Word Processing

SPECIALISED SOFTWARE APPLICATIONS  
UNDERTAKEN. RING FOR DETAILS

### 2 FOR JUST OVER THE PRICE FOR 1!

We now have limited stock of NEW CASSETTE DECKS, with built-in COUNTER + SOUND BOX FOR PETs.  
AT ONLY £65\* EACH.  
Orders dealt with in strict rotation

ALL GOODS SENT SAME DAY WHEREVER POSSIBLE  
LARGE S.A.E. FOR LISTS ETC.



# Working with the first prototype of Tuscan

Having encoded the ROMs, Mike Hughes takes delivery of the prototype.

WHILE THE prototype artwork was being converted into the printed circuit board, I had to turn my hand to more paper work and some mental acrobatics — all the specialised read-only memories had to be programmed.

Readers who have followed the series from the beginning will remember that the CPU-to-S-1000 interface required three ROMs to provide the Status, Control and DMA decoding; a further ROM is needed for the VDU control system and another for the character generator.

On top of those, I required some simple yet reliable system firmware which would have to be burned into a 2516 EPROM. It would present no problems because Transam would be able to re-locate and carry-out a few simple modifications to one of our Triton monitors. Although that would be written in 8080 code, it would be readable by the Z-80 and allow sufficient communications with the system to allow further software to be entered by hand. The VDU control ROM would be the same as used in Triton so no extra work would be needed in that direction.

## Character generator

That left the S-100 interface ROMs and the character generator. The most difficult of those to formulate would be the Status and Control decode devices. Not only would these be difficult to encode but I would have to be 100 percent sure that they were correct if I was to stand any chance of testing the prototype machine — one bit in error and I would be faced not merely with a software bug but the machine would not operate.

That was the one major worry I had. By using firmware of that type to control the hardware system, it would be very difficult to tell, in the event of the system failing to operate, if the error was in the ROMs or the printed circuit wiring.

To be as near sure as possible that the programs for the ROMs were correct, I decided to generate them by computer using Triton. By generating them within the Triton memory, I would be able to perform logic simulation trials on the codes for every possible Z-80 signal condition. Once checked and verified, I would be able to get a print-out listing and save the programs on tape. That tape would be used eventually to convey the data straight into the Transam ROM burner — obviating any possibility of errors being introduced by keystroke blunders.

If one considers four of the Z-80 control signals —  $\overline{WR}$ ,  $\overline{RD}$ ,  $\overline{MI}$  and  $\overline{IORQ}$  — it is possible to convert them into the basis of four S-100 signals by combinational logic gating. The S-100 signals I shall use in this example are SOUT, SINP, PDBIN and SINTA.

SOUT goes to logic level 1 when the CPU is outputting to a port and the Z-80 indicates this condition by making the  $\overline{WR}$  signal go to 0 at the same time as the

ones in the respective bits of the bytes which correspond to the address signal conditions as defined in the logic table. When all the ones had been inserted, the rest of the bits would, of necessity, be zero — table 1.

By referring to table 1, it can be seen that the data contained in each memory location will provide the correct level for the S-100 output signal when that address is generated by the corresponding Z-80 control signals.

For example, look at the data bit corresponding to SOUT. It is at logic level 1 whenever  $\overline{WR}$  is 0 and  $\overline{IORQ}$  is 0 and those conditions occur for locations 1, 3, 5 and 7. By checking through the logic statements for the other three S-100 signals, you can see that the data contained in the memory would generate those signals as well.

As I explained in an earlier instalment, I was able to execute the PCB design without having to worry about which output pin or address pin of the ROMs carried which signal because it could be taken into account when writing the program.

When looking at table 1 it is excusable to think that the right-hand column of the data, i.e., SINTA, represents the least significant bit of the four-bit byte. That does not have to be the case and the four data columns can be interchanged in position provided one knows which is which and, more importantly, which pin of the package carries that particular data bit. The same also applies for the address lines.

## Pin organisation

All one has to do now is re-organise the sequence of address and data bits to correspond with the pin organisation of the package and ensure that the correct data is written into the correct location.

The ROMs used in Tuscan had to be considerably more complex than this example because I would be using at least six source signals for the addresses and had to generate 11 S-100 signals from them. Nevertheless, the principle is exactly the same. Once the concept is understood, it is a simple operation to do the coding but as one can see there is plenty of opportunity for a careless mistake.

I was very glad I used computer simulation to check the codes because I had already calculated them manually and was relying on the computer to confirm

LOCATION	ADDRESS				DATA			
	$\overline{WR}$	$\overline{RD}$	$\overline{MI}$	$\overline{IORQ}$	SOUT	SINP	PDBIN	SINTA
1	0	0	0	0	1	1	1	1
2	0	0	0	1	0	0	1	0
3	0	0	1	0	1	1	1	0
4	0	0	1	1	0	0	1	0
5	0	1	0	0	1	0	1	1
6	0	1	0	1	0	0	0	0
7	0	1	1	0	1	0	0	0
8	0	1	1	1	0	0	0	0
9	1	0	0	0	0	1	1	1
10	1	0	0	1	0	0	1	0
11	1	0	1	0	0	1	1	0
12	1	0	1	1	0	0	1	0
13	1	1	0	0	0	0	1	1
14	1	1	0	1	0	0	0	0
15	1	1	1	0	0	0	0	0
16	1	1	1	1	0	0	0	0

Table 1.

$\overline{IORQ}$  signal is forced to 0. The logic of this can be more simply written as: SOUT is "1" WHEN  $\overline{WR}$  is "0" and  $\overline{IORQ}$  is "0"

In a similar manner, one can evolve the logic of the other signals — equating them in terms of the Z-80 control signals:

SINP is "1" WHEN  $\overline{RD}$  is "0" AND  $\overline{IORQ}$  is "0"

PDBIN is "1" WHEN  $\overline{RD}$  AND  $\overline{IORQ}$  are both "0" OR  $\overline{MI}$  AND  $\overline{IORQ}$  are both "0"

SINTA is "1" WHEN  $\overline{MI}$  AND  $\overline{IORQ}$  are both "0"

There are 16 possible combinations of logic levels one can have for the four signals  $\overline{WR}$ ,  $\overline{RD}$ ,  $\overline{MI}$  and  $\overline{IORQ}$ . These signals could be used, therefore, to address a memory having 16 locations each of which would contain a four-bit byte. If each bit of the memory bytes were to represent the signals we required, SOUT, SINP, PDBIN and SINTA, we could draw a table showing the 16 combinations of the addresses and insert

that all was well. As it turned out, I had made a silly mistake by the manual method — transposing two bits — and the computer simulation spotted it.

Compared to the interface ROMs, work on the character generator was great fun — albeit very time-consuming. Having learned a lesson on Triton, I had made sure that I would use a more logical organisation of addresses for the Tuscan VDU.

This time, I made the top seven address lines define the ASCII characters, 128 of them, while the bottom three lines would address the picture point rows for each character; eight of them for each character. I would require eight picture points in each row hence the choice of a 2708 EPROM which contains 1K by eight-bit bytes. By definition, I made a logical 1 represent a bright picture point and 0 a dark screen.

## Picture points

All one had to do was sit down with squared paper and work out the patterns of picture points and convert them into corresponding binary codes in a form which would suit the VDU control chip. The 96364 has a peculiarity in that anything appearing in the top row of the picture point cell, which makes up the character, is repeated in the bottom four rows.

Between those two, there sits a further seven rows making up a total of 12 rows as seen on the screen but, because of the repetitive operation on the top row, it is necessary to produce only eight rows' worth of picture point data. Each character cell for the 96364 is eight picture points wide and that corresponds perfectly to the eight-bit wide data held in the EPROM.

The letter "A" as seen on the TV screen within its character cell would appear thus:

```

.....@.....
.....@...@....
.....@.....@...
.....@.....@...
.....@.....@...
.....@@@@@...
.....@.....@...
.....@.....@...
    
```

Table 2.

ADDRESSES In Binary ASCII CODE ROW CODE		FULL ADDRESS In Hex	DATA Binary	Hex	REPRESENTATION
1000001	000	208	00000000	00	.....
1000001	001	209	00001000	08	.....@.....
1000001	010	20A	00010100	14	.....@...@....
1000001	011	20B	00100010	22	.....@.....@...
1000001	100	20C	00100010	22	.....@.....@...
1000001	101	20D	00111110	3D	.....@@@@@...
1000001	110	20E	00100010	22	.....@.....@...
1000001	111	20F	00100010	22	.....@.....@...
1000010	000	210	00000000	00	.....
1000010	001	211	00111100	3C	.....@@@@@...
1000010	010	212	00100010	22	.....@.....@...
1000010	011	213	00100010	22	.....@.....@...
1000010	100	214	00111100	3C	.....@@@@@...
1000010	101	215	00100010	22	.....@.....@...
1000010	110	216	00100010	22	.....@.....@...
1000010	111	217	00111100	3C	.....@@@@@...

A dot represents a dark picture point while '@' represents a bright point. To encode that, one has to convert the dots to 0 and the @ symbols to 1 and the bottom four lines can be ignored because they will automatically be repeats of the first. Encoded in binary and Hexadecimal, the letter A would be represented as follows:

Binary	Hex
00000000	00
00001000	08
00010100	14
00100010	22
00100010	22
00111110	3D
00100010	22
00100010	22

Letter "A" has the ASCII code 41H hence the seven high-order bits of its address in the EPROM must define that code — in binary this is 10000001. A further three address bits are used to identify each row of picture points hence the addresses which contain codes for the letters "A" and "B" and the codes contained therein — with graphic representation — table 2.

Those examples fall roughly in the middle of the EPROM memory map and in practice, a full 128 characters had to be encoded in this manner, starting at address 000 in memory running right way through to 3FF encompassing the full ASCII upper- and lower-case character sets, all punctuation and a selection of special graphics characters.

Although tedious, it is very easy to do the encoding and it is a very straightforward operation to produce customised character sets for foreign languages or other scientific applications.

By the time all the ROMs had been encoded and burned-in, the first prototype PCB had arrived back from the manufacturers. I have never been able to suppress the exciting anticipation of seeing the end product of months and months of painstaking work and it is always a thrill to see a crisp new PCB glistening with fresh electrolytic solder tinning. Invariably, the final board tends to look much more compact and neat and tidy as a result of the photo-reduction from the four-times life-size artwork.

Before attempting to solder any

components into place, I had to check all closely spaced tracks for leakage and short circuits — possibly caused by under-etching in the processing or blemishes on negatives. I invariably do that for a new prototype. Although a tedious job, it saves a good deal of time in the long run — one of the most difficult problems to pin-point in an assembled computer is a bridge between two busbar tracks.

At the same time, I had to do a thorough check on all the drilled holes to make sure none had been omitted — particularly where the plating through was carrying signals or power from one side of the board to the other. I was lucky — there were no obvious shorts but I had gained two or three extra holes where they were not expected and a couple of tracks were found to be missing on my original artwork.

All those points were noted so that the PCB manufacturers could re-program their drilling machine and I could up-date the artwork for, what would have to be, a second prototype in due course.

## Logical sequence

Fortunately, none of those errors would prevent my using the first board to test the circuitry, so the slow and careful job of checking the prototype design began in earnest.

The temptation I had to resist was that of treating the system as one would a fully-proved kit — there was no absolute certainty that it would work. I had to check each stage bit by bit which involved assembling the system a little at a time, hooking-up to the temporary power supply and testing each stage before moving on to the next.

My approach is to jot down a logical sequence for the first assembly and take plenty of time in analysing each step. The order I chose was:

1. A dry run of the bare PCB on the power supply to check that correct power was available at all the respective IC pins.
2. Check the master clock for operation.
3. Check all the clock dividers.
4. Check that the VDU operated by entering data manually.
5. Check for a correct power-on re-set pulse.
6. Insert the Z-80 and check that there was some life present — indicated by wild running of the address lines.
7. Insert the complete CPU circuitry and check that all address, data and control busbars were carrying signals — even though these would be wild owing to there being no memory present at that stage.
8. Add all address decoding, power-on jump system, monitor EPROM and sufficient RAM to create a stack to check that the system would initialise.

(continued on next page)

(continued from previous page)

9. Add a keyboard and test communications with the system.
10. Once communication had been established sequentially test all memory locations and ports under the control of the test monitor.
11. Add the RS232 driver/receiver and MODEM circuitry and test.
12. Add the interrupt encoder circuitry and test with simple interrupt-driven programs.
13. Test the system-mode select switches to ensure they had the correct sense and that the EPROM mask switch operated correctly.
14. Add various S-100 cards up to a full busbar loading to check a complete system.

As most of my designs are aimed at the home constructor, I make copious notes of any problems which might create practical difficulties in assembly so that they are not overlooked when the final instruction manual is written.

With this plan devised, a soldering iron, notepad, oscilloscope, frequency meter and DVM all to hand, I started. Disaster struck at the second stage — the master clock IC refused to oscillate. The incredible thing was that the only components involved were the IC itself, a crystal and a capacitor and it only goes to show how easy it is to make a silly mistake.

Inadvertently, I had used an IC for the clock from a manufacturer whose version will not operate from a single 5V supply rail. Easily said now, but it took a long time to realise the error; nevertheless, that was going to be a useful comment for the manual.

## Single difference

The divider for the VDU source worked satisfactorily but some more trouble arose regarding the divide-by-13 chip for the baud-rate generator. The principle I had adopted involved the truncation of a four-bit divider using a simple diode gate which fed back a crash re-set signal on a count of 13 — a technique I have used many times over with 100 percent success.

The only difference was that in this application, I was using low-power Schottky integrated circuits whereas before I had always used standard TTL for the technique. My first reaction was that it was a timing problem so high-speed diodes were substituted. Still no success, so some breadboarding on the side was called for and here I was in for a great surprise — in no way could I make a 74LS93 reliably truncate its count using a feedback re-set even with the highest-speed components.

A quick dive into the store and a standard 7493 was substituted with instant success. I have subsequently discussed the problem with other engineers and was surprised to find that I am not alone in

experiencing it — here was a change in component specification to Transam and a further word of warning for constructors.

To test the VDU required the insertion of all the components for that stage — it had to be tested in its entirety to see any sensible results. My faith in the trusty 96364 was instantly repaid with a rapid display of random characters on a perfectly-locked screen — furthermore the characters appeared properly which indicated my encoding for the character generator EPROM was correct.

By hooking-up eight wires to the eight input bits of the VDU system and bringing them out to a set of breadboard switches, I was able to check all the ASCII codes systematically and in so doing found another anomaly which, after further investigation, showed another short bit of PCB track had inadvertently been omitted.

## Quick patching

Some quick patching and all was well with the VDU apart from a note to alter the coding of the character-generator EPROM to make the font more readable for a few characters.

The power-on re-set pulse was quickly checked and found to be present and of sufficient duration, so now I had to enter more into the realms of the unknown.

On its own, the Z-80 chip showed the important signs of life so, undaunted, the rest of the CPU circuitry was inserted together with all the S-100 buffers and interface PROMs. A check with the oscilloscope showed that most of the S-100 lines of any importance had sprung to life but, of course, with no program or memory present, the CPU was running amuck.

By this stage, even the most die-hard engineer cannot help feeling a little excited as the next step involved the adding of memory and the output port chip to the VDU.

The monitor was inserted, the theoretical power-on jump address selected on the DIL switch and power was applied. Perhaps it was too much to hope for but I had expected the screen to jump into life and display the programmed initialisation message but, alas, all that appeared was the well-established random jumble of characters.

I well remember my heart sinking because this was the big crunch: the problem could have been anywhere; wrong address decoding, an erroneous concept in my novel power-on jump system, busbar problems, missing tracks, shorts between tracks which I had not noticed before or, worst of all a fundamental concept error in using PROMs.

It took many days of methodical work checking, probing and testing when eventually I found that a minor

transposition of two high-order address lines to the EPROM address decoder existed — I had put the monitor EPROM into the wrong socket. That had to be the cause of the trouble but with this put to rights the system still refused to initialise.

Nevertheless, the busbar signals started to show more sense and with the help of a borrowed logic analyser I was able to ascertain that the CPU was now addressing the monitor EPROM and receiving its first instruction; the problem seemed to be that it was reading only from memory and at no time did it attempt to write into the stack.

Although the Z-80 was trying to output data to memory the control busbar was not carrying the necessary signal to generate the required memory-write signal. The problem seemed to be associated with the status latch following my status decode ROM.

It was by a lucky chance, or maybe sixth sense, that I double-checked the number on my status latch and noticed that it was a 74LS374. At first, it did not convey anything because it is a perfectly normal edge-triggered latch and many of them were to be used in the Tuscan system. It took some time for me to remember my own design requirement that this chip had to be a transparent latch and not one of the edge-triggered variety to overcome certain pulse race problems which I had anticipated might exist.

## Exhilaration

It was pure carelessness on my part; I had inserted a 74LS374 when it should have been a 74LS373. That might have been a very understandable error for anyone other than myself.

A quick change of the offending chip, re-application of power and, miracle of miracles, the screen cleared and the monitor initialisation message appeared up bold and clear. To say I was surprised would be wrong but only those who have worked through a system like Tuscan from start to finish over a period of 12 months or so can understand the feeling of exhilaration when the system jumps into life.

From that moment on, it was plane sailing; the keyboard interface worked and communication was established with the system. Echo tests confirmed that the RS-232 interface was working as was the MODEM.

No other PCB track problems were encountered but I found I had underestimated some of the auxiliary supply currents from the on-board zener diode sources — they would have to be changed for IC voltage regulators.

During running up I had noticed a few areas on the board which could have been better laid-out so it only remained to return to the artwork and make a few amendments before putting things in motion for a second prototype. 



# “If you want what’s best for your PET, choose Commodore software.”

Kit Spencer  
General Manager  
of Commodore Systems  
360 Euston Road  
London NW1 3BL

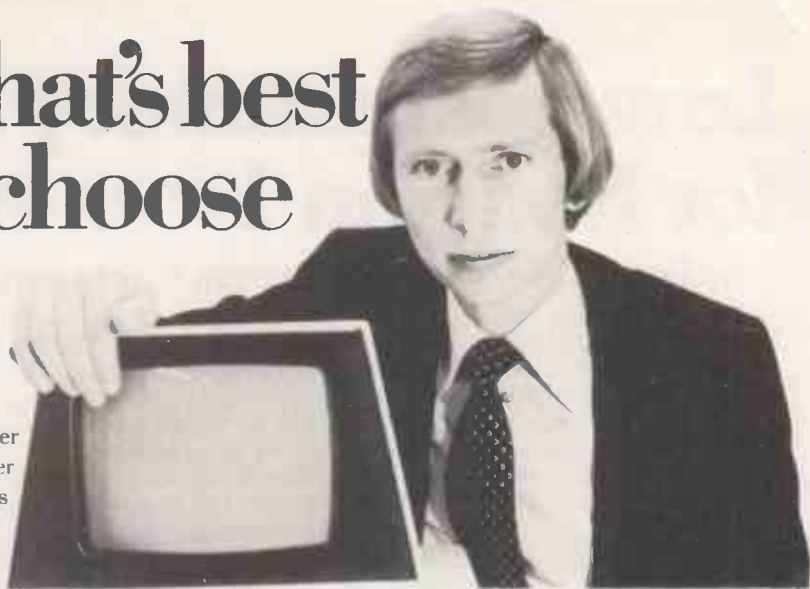

The Commodore PET is Britain’s best selling micro-computer, with over 10,000 already installed in a wide range of fields, including Education, Business, Science and Industry.

This has led to a tremendous demand for high quality software.

And Commodore has met this demand by producing a first class range of programs, now available from the nationwide network of Commodore Dealers.

Commodore’s support also includes training courses, a Users’ Newsletter and Official Approval for compatible products of other manufacturers who reach agreed standards.

## COMMODORE PETPACS

Over 50 Petpacs of programs are available (mainly on cassette) from Commodore Dealers.

These cover such popular titles as Strathclyde Tutorial, Statistics pack 1, Assembler Development System, Stock Market Trends and the Treasure Trove Collection of game packs including the award winning Star Trek, which is packaged with Petopoly. Prices are from £5 to £50.

## TRAINING COURSES AND SEMINARS

PET systems are simple to use and any normal advice or assistance

## NEW BUSINESS SOFTWARE PROGRAMS ON DISK

Commodore’s Floppy Disk Unit and high-speed Printer, combine with the PET to form a complete system (ideal for running a business) for under £2,500.

Commodore also produce a growing range of business software on disk available from Official Business Software Dealers.

### Business Information System – COMBIS £150 + VAT

Combis facilitates the storage and instant retrieval of all kinds of company records, from personnel files to mailing lists and printed address labels.

### Stock Control – COMSTOCK £150 + VAT

Comstock provides an accurate, up-to-the-second and comprehensive stock position for as many as 1,300 products.

### Word Processor – COMWORD £75 + VAT

Comword turns the system into an excellent word processor.

### Payroll – COMPAY £150 + VAT

Compay is a new, comprehensive payroll package.



you may need can be obtained from Commodore Dealers.

On the other hand, for rapid training on a basic or advanced level, you will certainly be interested in Commodore’s intensive 2 and 3 day residential courses. We also run one day general appreciation seminars.

## PET USERS’ NEWSLETTER

This is Commodore’s official method of sharing new information and ideas between the many thousands of PET users. The newsletter is published regularly and for an annual subscription of £10 you can start receiving copies now.

Look out for this sign. It tells you that compatible products of other manufacturers have met with our standards of approval.



(Tick the appropriate boxes)

To: Commodore Information Centre, 360 Euston Road, London NW1 3BL 01-388 5702

I am a PET owner  Please put me in touch with my nearest dealer

Please send me details of: Commodore PET Software

Training Courses & Seminars  I would like to receive the Users’

Newsletter and enclose £10 annual subscription

PC11

Name \_\_\_\_\_

Address \_\_\_\_\_

Tel. No. \_\_\_\_\_

**commodore**  
We made small computers big business.

• Circle No. 175

# Low-cost memory expansion for Nascom 1

John Dawson describes an expansion RAM board for the Nascom computer.

THERE ARE many attractions in having a larger memory for the Nascom 1 — larger programs can be written in any language. A print program, *Practical Computing*, July 1980, can be held in an increased memory and called by other programs which would otherwise fill the unexpanded RAM, and more than one

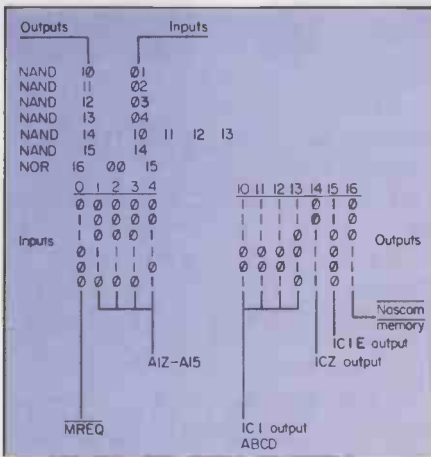

Figure 4.

screenfull of information may be held ready for immediate access.

Although the board which is the basis of the article has only 2K of RAM at present, there is no reason why further 2114 ICs should not be added to give a total of four or six kilobytes.

Each 2114 requires only 10 microamps input current and has a typical output low current of 6mA. The RAM ICs drive only the buffer chips on the buffer board and

the other 2114s, if no other boards are plugged into the Nasbus.

The expansion memory board is economical to build and should cost less than £20 for 2K of RAM. A Nascom buffer board kit is necessary. The changes that have to be made to the Nascom main board are described in the booklets accompanying the kit.

The circuit is shown in figure 1a and 1b. One pair of 2114 static RAM chips is shown with connections off the page to subsequent pairs of ICs. ICs one, two and three decode the highest four address lines and are gated with the  $\overline{MREQ}$  signal to enable the internal Nascom memory when locations lower than 1000Hex are addressed.

When locations in the external memory are addressed, the Nascom memory line is high and that signal is gated in IC5b with the inverted RD signal to enable the DBDR line. IC4 decodes the lowest 16K of memory from four address lines.

The lower four outputs are never used as these correspond to the monitor ROM, 2K, video RAM, 1K, and user RAM, 1K, on the main board.

Output for from the 74 LS 154 selects locations 1000 Hex to 13FF Hex and output five selects 1400 Hex to 17FF Hex. From the 16-line decoder, 10 outputs are spare and could be used to enable more 2114 RAM pairs or 2708 1K ROM ICs. The  $\overline{WR}$  line is wired to the write enable ( $\overline{WE}$ ) pins on all the RAM ICs.

A pin-out chart for all the ICs used on the memory board is set out in figure 2. The ICs are shown from the top, using

conventional notation, and care should be taken to reverse the pins from left to right when the IC socket is viewed from the copper/soldering side of the Veroboard. The lay-out used is shown diagrammatically in figure 3. Whatever design is chosen it is vital that the copper tracks are broken between the backplane connector and the pins of the ICs. Terminal pins may be inserted into the tracks that connect to the bus lines set-out in table 1 and it is useful to attach a strip of paper down the board with the function written opposite each pin.

All connections between Nasbus connector and IC sockets must be cut before wiring is started, there are other signals

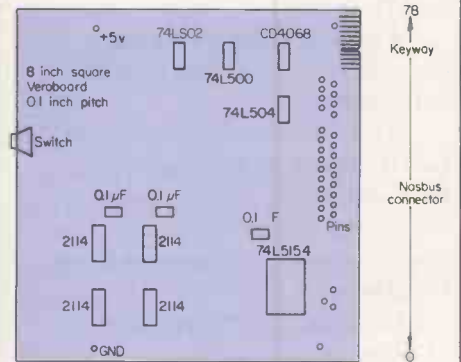

Figure 3.

present on the bus that will conflict with the circuitry on the board.

The board was wired using a Verowire pen and pins broken from a continuous strip for the IC sockets. By the time the board was completed, it was clear that the break-off-as-required type of socket is not good enough for experimental work.

They may be satisfactory for one-time use but are not suitable for a project where re-soldering may be necessary. Sockets save time and help with the wiring in the following way: the Verowire pen has a spool of wire in the handle which is fed through a finger-controlled clamp to a fine nozzle in the tip.

Connections are made by inserting a short length of wire into the hole in the Veroboard containing the socket pin, wrapping two turns around the pin and drawing the pen away. The wire is anchored sufficiently firmly for the pen to be drawn across the board, either directly to the other connection, or by way of plastic combs supplied with the kit.

The combs plug into the board and are valuable for separating and ordering multiple wires such as the address and data buses.

Verowire is covered with a polyurethane

Figure 1a.

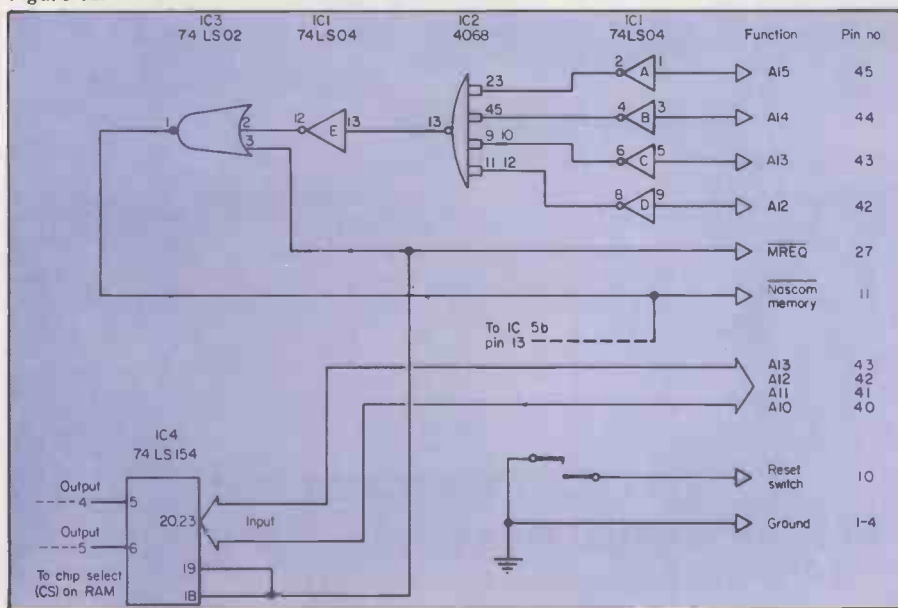

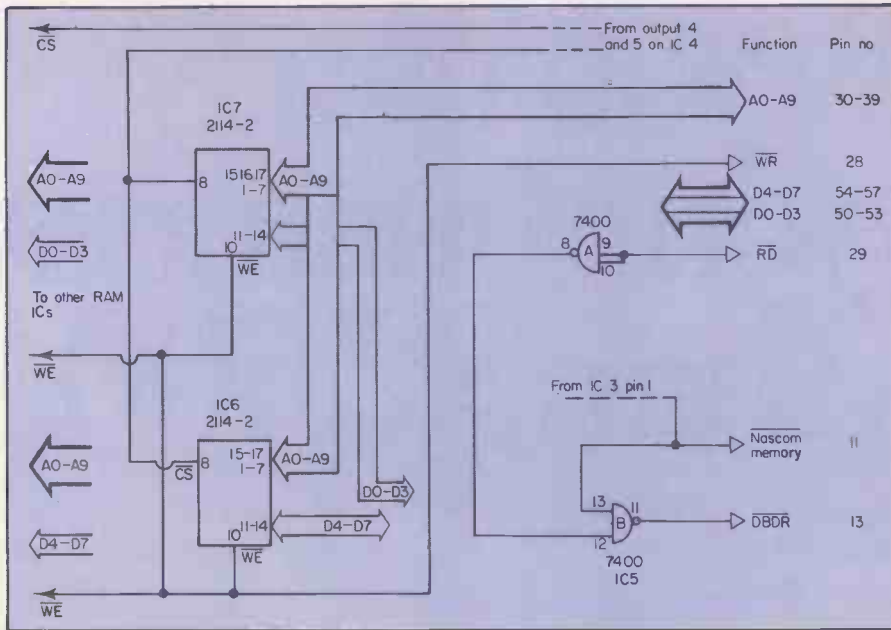

Figure 1b.

insulation which melts slightly below soldering temperatures. The great advantage of that system of wiring is that a joint can be made anywhere along the wire without having to cut and strip in an orthodox manner.

Address lines, for example, have to be connected to two or more RAM ICs. Using Verowire, the pen is simply taken from the terminal pin by the backplane connector, via a comb, to the IC sockets. The wire is wrapped round each of the required pins, held under slight tension while the end joints are made, and then soldered at the intermediate points.

There are two other groups of components on the expansion board. A re-set switch was mounted on the outer edge of the board; with static memory ICs, the new re-set switch is not essential and the main board re-set switch can remain undisturbed. Two or three 0.1 microfarad capacitors were placed across the power lines close to the RAM ICs and the decoding chips.

The +5 volt tracks were connected together as were the ground tracks to improve the contact with the backplane socket. Power wires to the ICs were made of a heavier gauge than the Verowire.

Terminal pins were placed in the board early in the construction and this made it possible to attach voltmeter and oscilloscope probes to particular lines during subsequent testing. The pattern made by the pins complemented the written information on the paper strip and helped to identify groups of lines. The 78 copper tracks were confusing at times; it is a long count from the bottom of the board without help.

Verowire has one major disadvantage, it is all the same colour. Checking the wiring on the board cannot be done visually and testing with an ohmmeter is the easiest method before the ICs are inserted.

The idea that it should be a simple matter to build an additional memory board for the Nascom was not difficult;

Table 1. Connections to backplane.

Pin	Function
1-4	0 Volts — Ground
10	Initiates a system re-set when taken low.
11	Must be taken low on an expanded system when the 4K ROM/RAM on the main board is to be enabled.
13	Must be driven low when the CPU wishes to read data from the RAM on the expansion board.
27	Z-80 Memory Request line.
28	Z-80 Write line.
29	Z-80 Read line.
30-45	Z-80 Address bus. A0-A15
50-57	Z-80 Data bus. D0-D7
72	Keyway — no connection.
75-78 + 5 Volts	Power

Figure 2.

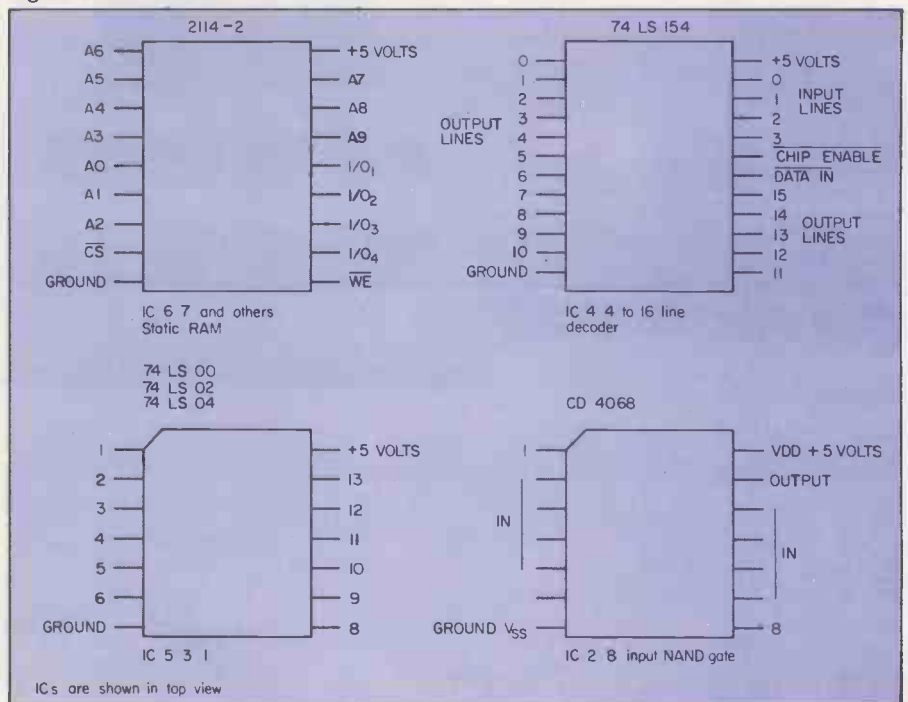

the realisation of that idea involved weeks of frustrating trial and error.

After some of the logic errors that appeared in the original design without harm to the Nascom buffer board, the resilience of the circuits to which the RAM board was attached can only be described as marvellous.

With the correct logic established the board worked, to the extent that it allowed locations to be written to and read from although the low byte always returned to an odd number. Odd numbers were returned accurately, even numbers were increased by one.

After spending hours trying to decipher timing patterns on an oscilloscope and changing ICs on the buffer board it seemed that there might be some frightful, lurking dynamic, timing problem impossible of diagnosis without sophisticated test equipment. The answer is obvious now but it took a long time to find the broken wire in data bit 0 in the ribbon cable connecting the buffer board to the main Nascom board.

Since then, the expansion RAM has worked without fault. A printout of the logic emulator program describing the decoding necessary for part of the RAM board is shown in figure 4. The logic emulator effectively fills the user RAM in the original Nascom and the print program is held at 1650 Hex, an unknown address on the original computer.

The wiring method has been described in detail as it is an important part of the construction. A wiring pen is the key to the project. Remember to isolate the copper tracks used by each IC pin from opposite pins on the same socket, from neighbouring sockets and from the backplane connector.

Wherever possible, the board was built with parts that were already available.

# Now you can control your business for less than £2,500.

This could be your best investment opportunity yet. A complete computerised business system, including a Floppy Disk Unit, high-speed Printer and *Britain's best selling microcomputer* – the Commodore PET. All for under £2,500.

## First Class Programs

A comprehensive range of first class programs is offered by *Commodore 'Business Software' Dealers*. These are available on disk from £50-£500. And they cover such applications as *Business Information, Stock Control, Word Processing, Payroll, Accounting and Mailing Systems*.

## Service and Support

With over 10,000 PET computers installed in the UK, dealer support is growing fast. A nationwide network of 90 official

*Commodore 'Business Software' Dealers* ensures that service and technical facilities are close to every PET user. Our dealers can even offer you a 24 hour on-site maintenance agreement.

## Training and Instruction

The PET Business System is self-contained and simple to use. Should you require personalised programs or extensive installation training this can be arranged with your *Commodore 'Business Software' Dealer* who can also give details of official *Commodore Training Courses*. These include intensive 2 & 3 day workshops to train you to write your own programs.

For full details about the Commodore PET Business System, Training Courses, Programs, and *'Business Software' Dealers*, simply fill in the coupon and post today.



To: Commodore Information Centre,  
360 Euston Road, London NW 1 3BE.

Please send me details of the PET Computer Business Systems.

Name \_\_\_\_\_

Position \_\_\_\_\_

Company \_\_\_\_\_

Address \_\_\_\_\_

Tel. No. \_\_\_\_\_

If you have a particular application in mind please specify:

\_\_\_\_\_

\_\_\_\_\_

\_\_\_\_\_

PCB11

**commodore**  
We made small computers big business.

• Circle No. 176

## Cursor addressing

ONE FEATURE in most Basics on personal computers which is invaluable for games' writers is the Poke statement. Sharp MZ-80K Basic is no exception writes Peter Gardner of Munich, West Germany.

Another feature some rival Basics have, but which the Sharp Basic lacks, is the ability to cursor address, i.e., position anywhere on the screen, the start of a print statement.

Here is a small Basic program for the Sharp SP-5025 Basic — the version most cassette-based users possess — which modifies the Basic interpreter, and then saves the modified interpreter on to cassette for further use.

The modification? To allow you to Cursor Address the start of your PRINT statements, e.g.,

PRINT [10,20] "IN THE MIDDLE" will put the text "IN THE MIDDLE" at line 10 down, and character 20 across — both counts starting from 0, to be consistent with the set and re-set statements in Sharp Basic.

The positions do not have to be constants — they may be variables — and are checked for correct range — down 0-24, across 0-39.

- Here is the program, the instructions for use are simple.
- Load the Basic SP-5025 afresh.
- Type-in the program and check it carefully.
- Put a blank or unwanted tape into the cassette unit.
- Type RUN.
- If all has gone correctly, you should obtain,

WRITING BASIC SP-5025A and the interpreter will save its modified self for future use.

- The final check — the program writes finished in the middle of the screen using the newly-Poked code.

```

1 DATA 205,139,22,91,69,28,205,169
2 DATA 25,123,254,25,210,152,19,50
3 DATA 114,17,205,154,22,44,205,169
4 DATA 25,123,254,40,210,152,19,50
5 DATA 113,17,205,154,22,93,195,69,28
6 FOR I = 15836 TO 15876: READE:
   POKE I, E: NEXT
7 POKE 7221, 220: POKE 7222, 61
8 POKE 4354, 5: POKE 4355, 44
9 POKE 4350, 65: POKE 4351, 13
10 USR(33): USR(36)
11 PRINT "[C]": PRINT [10,16]
   "FINISHED"
    
```

## Nim in 240 bytes

IN THE version of Nim, the object is to remove the last match writes Andrew Jones of Caldicot, Gwent. There can be up to six piles with up to 15 in each pile; you and the Mk 14 take turns to remove as many as you like from any pile.

To set-up the piles, fill locations OF12—OF17 — RHnd Byte only — with your chosen amounts. Then start the program from OF1A.

The computer will display six piles in the Format 0123 — 45 to remove matches enter pile number and then the number of matches you wish to remove, two matches

For all users of systems based on the Z-80 chip, Z-80 Zodiac offers an opportunity to have programs and ideas published. We pay at least £5 for each contribution used.

from LH pile, press 0,2. If you try to remove too many, the computer will not accept it and you must start again.

```

OF12 OX PILE 0
OF13 OX PILE 1
OF14 OX PILE 2
OF15 OX PILE 3
OF16 OX PILE 4
OF17 OX PILE 5
OF19 — COUNT 1
OFF9 — COUNT 2
    
```

To let the computer try, press MEM at any time — beware of double bounce.

The program deliberately allows cheating. Either you or the computer can go twice so if it catches you early on you can try again.

This program operates on an expansion of that method. It considers the piles in binary format and returns an even number of each bit to you. Thus, given piles containing five, seven, eight and six matches. The computer performs an XOR instruction on them to discover which bits are uneven.

```

                0101
XOR            0111
XOR            1000
XOR            0110
GIVES          1100
    
```

The computer tries to remove those uneven bits by XORing them with each pile in turn until the new number is less than the old one. It, therefore, XORs 1100 with 1000 to give 0100 and all the bits are now even and you have lost.

```

OF1A SET(H) C401 LD1 01      Initialise p2 to RAM
O F I C37  XP-             & P3 to monitor display
           AH(3)          monitor display
OF1D      C4 OF          LD1 OF
OF1F      36             XPAH(2)
OF20 SET(I) C4 3F          LD1 3F
OF22      33             XPAL(3)
OF23      C4 00          LD1 00
OF25      32             XPAL(2)
OF26 SET(D) C2 12          LD(2)
OF28      1E 1E          RR, RR
OF2A      1E 1E          RR, RR
OF2C      E2:13          XOR(2)
OF2E      CA OE          ST(2)
OF30      C2 14          LD(2)
OF32      1E 1E          RR, RR
OF34      1E 1E          RR, RR
OF1A SET(H) C401          LD1 01
OF1C      37             XPAH(3)
OF1D      C4 OF          LD1 OF
OF1F      36             XPAH(2)
OF20 SET(I) C4 3F          LD1 3F
OF22      33             XPAL(3)
OF23      C4 00          LD1 00
OF25      32             XPAL(2)
OF26 SET(D) C2 12          LD(2)
OF28      1E 1E          RR, RR
OF2A      1E 1E          RR, RR
OF2C      E2:13          XOR(2)
OF2E      CA OE          ST(2)
OF30      C2 14          LD(2)
OF32      1E 1E          RR, RR
OF34      1E 1E          RR, RR
OF36      E2 15          XOR(2)
OF38      CA OC          ST(2)
OF3A      C2 16          LD(2)
OF3C      1E 1E          RR, RR
OF3E      1E 1E          RR, RR
OF40      E2 17          XOR(2)
OF42      CA OD          ST(2)
OF44 D,MOVE 3 F          XPPC(3)
OF45      90 1B          JMP
OF47      40             LDE
OF48      CA 55          ST(2)
    
```

```

CA 5D ST(2)      Store in UU
OF4C 8F FF      DLY
OF4E 3F          XPPC(3)
OF4F 90 11      JMP
OF51 C4 12      LDE 12
OF53 32          XPAL(2)
OF54 C2 TT      LD P(2)
OF56 03          SCL
OF57 78          C A E
OF58 94 02      JP
OF5A 90 02      JMP
OF5C CA UU      STP(2)
OF5E 8F FF      DLY
OF60 90 BE      JMP
OF62 CHECK C4 12 LD1
OF64 32          XPAL(2)
OF65 C4 00      LD1
OF67 C8 07      ST
OF69 01          XAE
OF6A C4 FF      LD1
OF6C C8 15      ST
OF6E C2 vv      LD(2)
OF70 98 04      JZ
OF72 70          ADE
OF73 01          XAE
OF74 A8 OD      ILD
OF76 A8 F8      ILD
OF78 E4 06      XR1
OF7A 98 02      JZ
OF7C 90 FO      JMP
OF7E 40          LDE
OF7F 98 4F      JZ
OF81 C4 WW      LD1
OF83 98 51      JZ
OF85 CMOVE C2 00 LD(2)
OF87 E2 01      XRO(2)
OF89 E2 02      XRO(2)
OF8B E2 03      XRO(2)
OF8D E2 04      XRO(2)
OF8F E2 05      XRO(2)
OF91 98 15      JZ
OF93 01          XAE
FO94 CHSE C2 00 LD(2)
OF98 60          XRE
OF97 C8 61      ST
OF99 C6 01      LD@(2)
OF9B 03          SCL
OF9C F8 5C      CAD
OF9E 94 02      JP
OFAO 90 F2      JMP
OFA2 CO 56      LD
OFA4 CE FF      ST @(2)
OFA6 90 B8      JMP
OFA8 CLVER C4 00 LD1
OFAA C8 OE      ST
OFAC C4 01      LD1
OFAE C8 OD      ST
OFBO C4 06      LD1
OFB2 CA 07      ST(2)
OFB4 AGN BA 07 DLD(2)
OFB6 98 0F      JZ
OFB8 C2 xx      LD(2)
OFBA 03          SCL
OFBB FA yy      CAD(2)
OFBD 94 04      JP
OFBF CO FC      LD YY
OFC1 C8 F7      ST XX
OFC3 INC A8 F8 ILD YY
OFC5 90 ED      JMP
OFC7 REM CO F1 LD XX
OFC9 C8 02      ST zz
OFCD BA xx      DLD(2)
OFCD 90 D7      JMP
OFCD 08          NOP
OFDO I LOSE C4 30 LD1
OFD2 CA F4      ST(2)
OFD4 90 04      JMP
OFD6 U LOSE C4 3E LD1
OFD8 CA F4      ST(2)
OFDA COMM C4 00 LD1
OFDC 32 08      XPAL(2),NOP
OFDE C4 38      LD1
OFDE CA 04      ST(2)
OFDE C4 3F      LD1
OFE4 CA 03      ST(2)
OFE6 C4 6D      LD1
OFE8 CA 02      ST(2)
OFEA C4 79      LD1
OFEA CA 01      ST(2)
OFEA C4 00      LD1
OFF0 CA 07      ST(2)
OFF2 CA 05      ST(2)
OFF4 CA 00      ST(2)
OFF6 3F          XPPC(2)
OFF7 90 D4      JMP
    
```

# Buy a microcomputer for under £1,000 and you could be on your own! Unless it's a Commodore PET.



Commodore produce Britain's number one microcomputer. But we don't stop there. We also insist on providing comprehensive support throughout our national dealer network.

Our dealers can examine your needs and demonstrate which hardware and software will suit you best. Their trained engineers are always at hand and a 24-hour field maintenance service is available. Your local dealer can tell you more about the following Commodore Services.

**Commodore PET**  
The Commodore PET computer range covers everything from the self-contained unit at under £500 to complete business systems at under £2,500.

**Commodore Business Software and Petpacks**  
Our software range covers hundreds of applications. Business software includes Sales and Purchase Ledgers, Accounting, Stock Control, Payroll, Word Processing and more. In addition over 50 Petpacks are available covering such titles as Strathclyde Basic Tutorial, Assembler Development System, Statistics, plus our Treasure Trove and Arcade series of games.

**Commodore Approved Products**  
Compatible products of other manufacturers with Commodore's mark of approval are also available.

**Commodore Courses**  
Commodore offer a range of residential training courses and one day seminars. An excellent start. And when you have installed your system the PET User's Club Newsletter can keep you informed of new ideas and latest developments.

## LONDON AREA

Adda Computers Ltd,  
W5, 01-579 5845  
Advanced Management Systems,  
EC2, 01-638 9319  
Bytshop Computerland,  
W1, 01-636 0647  
C.S.S. (Business Equipment) Ltd,  
E8, 01-254 9293  
Capital Computer Systems,  
W1, 01-636 3863  
Centralex-London Ltd,  
SE13, 01-318 4213  
Cream Microcomputer Shop,  
HARROW, 01-863 0833  
Da Vinci Computer Shop,  
EDGWARE, 01-952 0526  
L & J Computers,  
NW9, 01-204 7525  
Home and Business Computers,  
E12, 01-472 5107  
Merchant Systems Limited,  
EC4, 01-353 1464  
Metclean Ltd,  
SW1, 01-828 2511  
Micro Computation,  
N14, 01-882 5104  
Micro Computer Centre,  
SW14, 01-878 3206  
Sumlock Bondain Ltd,  
EC1, 01-250 0505  
Sumlock Bondain Ltd,  
EC4, 01-626 0487  
T.L.C. World Trading Ltd,  
WC2, 01-839 3894  
TOPS TV LTD,  
SW1, 01-730 1795

## HOME COUNTIES

G. M. Marketing,  
ANDOVER, 790922  
HSV Microcomputers,  
BASINGSTOKE, 62444  
MMS Ltd,  
BEDFORD, 40601  
Elex Systems Ltd,  
BRACKNELL, 52929  
DDM Direct Data Marketing Ltd,  
BRENTWOOD, 229379  
Amplicon Micro Systems Ltd,  
BRIGHTON, 562163  
RUF Computers (UK) Ltd,  
BURGES HILL, 45211  
T & V Johnson (Microcomputers  
Etc) Ltd, CAMBERLEY, 20446  
Cambridge Computer Store,  
CAMBRIDGE, 65334  
Wego Computers Ltd,  
CATERHAM, 49235  
Dataview Ltd,  
COLCHESTER, 78811  
South East Computers Ltd,  
HASTINGS, 426844  
Alpha Business Systems,  
HERTFORD, 57423  
Brent Computer Systems,  
KINGS LANGLEY, 65056  
Isher-Woods Business Systems,  
LUTON, 418202  
South East Computers Ltd,  
MAIDSTONE, 681263  
Micro Facilities Ltd,  
MIDDLESEX, 01-979 4546  
J. R. Ward Computers Ltd,  
MILTON KEYNES, 562850  
Sumlock Bondain (East Anglia) Ltd,  
NORWICH, 26259  
T & V Johnson (Microcomputers  
Etc) Ltd, OXFORD, 721461  
H.S.V. Microcomputers,  
SOUTHAMPTON, 22131  
Super-Vision,  
SOUTHAMPTON, 774023  
Xitan Systems Ltd,  
SOUTHAMPTON, 38740  
Stuart R Dean Ltd,  
SOUTHEND-ON-SEA, 62707  
The Computer Room,  
TUNBRIDGE WELLS, 41645  
Orchard Electronics,  
WALLINGFORD 35529

Petalect Ltd,  
WOKING, 63901  
Oxford Computer Systems,  
WOODSTOCK, 811976

## MIDLANDS AND SOUTH HUMBERSIDE

Bytshop Computerland,  
BIRMINGHAM, 622 7149  
CPS (Data Systems) Ltd,  
BIRMINGHAM, 707 3866  
Camden Electronics,  
BIRMINGHAM, 773 8240  
Computer Services Midlands Ltd,  
BIRMINGHAM, 382 4171  
Catlands (Computers) Ltd,  
BURTON-ON-TRENT, 812380  
Ibek Systems,  
COVENTRY, 86449  
Jondane Associates Ltd,  
COVENTRY, 664400  
Davidson-Richards Ltd,  
DERBY, 366803  
Caddis Computer Systems Ltd,  
HINCKLEY, 613544  
H.B. Computers,  
KETTERING, 83922  
Taylor-Wilson Systems Ltd,  
KNOWLE, 6192  
Machsize Ltd,  
LEAMINGTON SPA, 312542  
Office Computer Techniques Ltd,  
LEICESTER, 28631  
Lowe Electronics,  
MATLOCK, 2817  
Betos (Systems) Ltd,  
NOTTINGHAM, 48108  
Bytshop Computerland,  
NOTTINGHAM, 40576  
Keen Computers Ltd,  
NOTTINGHAM, 583254  
Tekdata Computing,  
STOKE-ON-TRENT, 813631  
Systems Micros,  
TELFORD, 460214  
McDowell Knaggs & Associates,  
WORCESTER, 427077

## YORKSHIRE AND NORTH HUMBERSIDE

Ackroyd Typewriter & Adding  
Machine Co. Ltd, BRADFORD, 31835  
Allen Computers,  
GRIMSBY, 40568  
Microware Computers Ltd,  
HULL, 562107  
Microprocessor Services,  
HULL, 23146  
Holdene Ltd,  
LEEDS, 459459

South Midlands Communications Ltd,  
LEEDS, 782326

Yorkshire Electronics Services Ltd,  
MORLEY, 522181  
Computer Centre (Sheffield) Ltd,  
SHEFFIELD, 53519  
Electronic Services,  
SHEFFIELD, 668767  
Hallam Computer Systems Ltd,  
SHEFFIELD, 663125

## NORTH EAST

Dyson Instruments,  
DURHAM, 66937  
Currie & Maughan,  
GATESHEAD, 774540  
Wards (Office Supplies) Group,  
GATESHEAD, 605915  
Eltron Ltd,  
HARTLEPOOL, 61770  
Fiddes Marketing Limited,  
NEWCASTLE, 81517  
Newcastle Computer Services,  
NEWCASTLE, 615325  
Format Micro Centre,  
NEWCASTLE, 21093  
Tipton Associated Systems  
Consultants Ltd,  
SUNDERLAND, 73310

## SOUTH WALES AND WEST COUNTRY

Radan Computational Ltd,  
BATH, 318483  
Computer Corner,  
BAYSTON HILL, 4250  
Bristol Computer Centre,  
BRISTOL, 23430  
C.S.S. (Bristol) Ltd,  
BRISTOL, 779452  
T & V Johnson (Microcomputers  
Etc) Ltd, BRISTOL, 422061  
Sumlock Tabdown Ltd,  
BRISTOL, 26685  
Sigma Systems,  
CARDIFF, 34869  
Office and Business Equipment  
(Chester) Ltd, DEESIDE, 817277  
A.C. Systems,  
EXETER, 71718  
Micro Media Systems,  
NEWPORT, 59276  
J.M. Computer Services Ltd,  
NEWQUAY, 2863  
Devon Computers,  
PAIGNTON, 526303  
J.A.D. Integrated Services,  
PLYMOUTH 62616  
Business Electronics,  
SOUTHAMPTON, 738248  
Computer Supplies (Swansea),  
SWANSEA, 290047

## NORTH WEST AND NORTH WALES

Tharstern Ltd,  
BURNLEY, 38481  
B + B (Computers) Ltd,  
BOLTON, 26644  
Preston Computer Centre,  
PRESTON, 57684  
Callands (Computers) Ltd,  
WILMSLOW, 52 7156

## LIVERPOOL

Aughton Microsystems Ltd,  
LIVERPOOL, 548 7788  
B.E.C. Computers,  
LIVERPOOL, 263 5738  
Rockliff Brothers Ltd,  
LIVERPOOL, 521 5830

## MANCHESTER AREA

Bytshop Computerland,  
MANCHESTER, 236 4737  
Computastore Ltd,  
MANCHESTER, 832 4761  
Cytek (U.K.) Ltd,  
MANCHESTER, 872 4682 -  
Executive Reprographic Ltd,  
MANCHESTER, 228 1637  
N.S.C. Computer Shops Ltd,  
MANCHESTER, 832 2269  
Sumlock Electronic Services  
(Manchester) Ltd,  
MANCHESTER, 834 4233  
Professional Computer Services Ltd,  
OLDHAM, 624 4065  
D. Kipping Ltd,  
SALFORD, 834 6367  
Automated Business Equipment Ltd,  
STOCKPORT, 061-432 0708

## SCOTLAND

Holdene Microsystems Ltd,  
EDINBURGH, 668 2727  
Microcentre,  
EDINBURGH, 556 7354  
Aethorol Consultancy Services,  
GLASGOW, 641 7758  
Bytshop Computerland,  
GLASGOW, 221 7409  
Robox Ltd,  
GLASGOW, 221 5401  
Mac Micro,  
INVERNESS, 712203  
Thistle Computers,  
KIRKWALL, 3140

## IRELAND

Softech Ltd,  
DUBLIN, 784739  
Medical & Scientific Computer  
Services Ltd, LISBURN, 77533

To: Commodore Information Centre,  
360 Euston Road, London W1 3BL. 01-388 5702

Please send me further information about the Commodore PET.

Name \_\_\_\_\_  
Position \_\_\_\_\_  
Address \_\_\_\_\_  
Intended application \_\_\_\_\_ PCD 11  
Do you own a PET? YES  NO

**Commodore**

This list covers dealers participating in our advertising.

• Circle No. 177

We have had so many requests for advice about software for the little ZX-80 that we have decided to start a club page devoted to the machine. If you have a contribution to make, write to *Practical Computing* marking your letter ZX-80 Line-up. We pay £5 for contributions published.

## Memory-mapped access

HAVING experimented with my ZX-80 for a few days, I have developed the following program writes J C Minter of Tadley, Hampshire. It should be of interest since it illustrates the use of the Poke instruction, in conjunction with system variables, to allow memory-mapped access to the screen.

The program clears an area of screen for use by the sketching cursor. Any of the usual characters may be used for drawing, and the cursor may be set to a non-destructive mode.

```

1   CLS
2   LET P=0
3   LET N=0
4   LET SC=0
5   LET L=200
10  FOR X= TO 512
20  PRINT " ";
30  NEXT X
40  PRINT "
50  LET _____ "
    S=PEEK(16396)+PEEK(16397)
    *256+4
100 KINPUT A
105 POKE S,P+N
107 IF NOT SC=0 AND NOT N=0
    THEN POKE, S,SC
    GO TO 120+A*2
110 INPUT SC
121 GO TO L
122 STOP
130 LET S=S-1
131 GO TO L
132 LET S=S+S+33
133 GO T>L
134 LET S=S-33
135 GO TO L
136 LET S=S+1
137 GO TO L
138 LET N=N+128
139 IF N>128 THEN LET N=0
200 LET P=(S)
205 IF P=3 AND NOT SC=3 THEN
    LET S=S-33
210 POKE S,20
220 GO TO 100

```

When the program is run, there will be a pause after which the screen displays a black line across the screen. The upper half of the division is the memory-mapped area. A numeric input is required, and there are several options available:

1. End program.
- 5,6,7,8 Move cursor in direction above key.
- 9 Toggle cursor write/non-destructive mode.
- 0 Accept special character.

When first run, the cursor is in non-destructive mode. It is not initially on display. Pressing 5 then new-line causes it — a "\*" — to appear. It may be moved using keys 5-8 — remembering new-line after each command. Command "g" sets the cursor in draw mode. If it is moved in that mode, it leaves a trail. If no special character is in use, anything the cursor passes over will be inverted.

Option "0" sets the cursor to draw with a user-specified character. After "0" is entered, the cursor disappears and another input requested. This should be the code of your required character — see manual, pages 76 and 78. Once entered the cursor will re-appear and any drawing will print your character. To change the character, use option 0 again. To return to normal mode, select option 0 and give code 0.

At any stage, option 9 will cause the cursor to go non-destructive if in draw mode, or enter draw mode if in non-destructive mode. Option 1 stops the program. Do not go off the screen; you are likely to crash the system. Here is an explanation of certain lines which might not be clear:

Lines 10-40 fill the upper part of the screen with spaces. That is necessary if the area is to be Poked to. Line 40 denotes the bottom of the available area; the graphic character is shift-W.

Line 50 finds the decimal address of the start of the display file, and sets the cursor to just after it.

Lines 105 and 107 place the desired character on the screen depending if you are in ordinary or special character modes.

Line 110 and lines 120-139 control the options.

Line 205 stops you going off the bottom.

Line 210 places the cursor.

As a final matter of interest, can anyone explain what happens if you do the following? Toggle cursor to draw, select option 0 and define character as 254. Do two cursor-lefts. The effect is not permanent; end the program and re-run will restore to normal. Thanks for an interesting new section in your magazine. Anyone managing, via machine code, to obtain moving graphics, should contact me and tell me how its done.

## Life program

HERE is a listing of Life for minimum ZX-80s sent to us by Peter Ansell of Cambridge. When the program is run, entering co-ordinates of cells — X and Y values separated by new-lines — will cause them to flip states — on to off or off to on.

As each co-ordinate is entered the present cell pattern is displayed. X and Y values must be in the range of one to 13, if a value of X is given as zero then pattern generation begins.

Pattern generation takes two to 40 seconds, depending on how large an area the pattern takes. On large area patterns

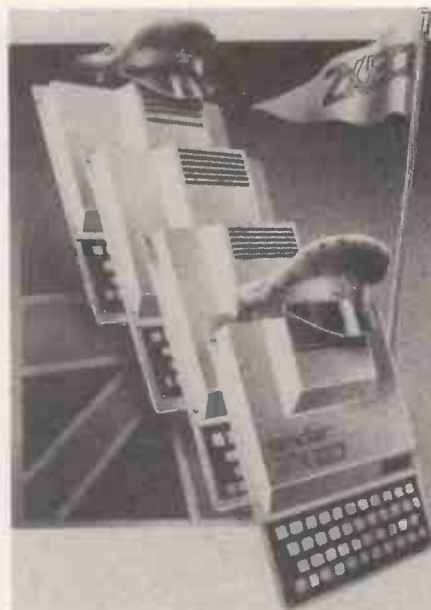

at the string input request, the computer may run out of memory, if this happens simply tell it to continue.

The string input is primarily to make the computer pause, but if it receives anything but a null string it will stop, also if there are no cells on the computer stop.

Without major alteration to the program and with memory expansion, it should be possible to allow values in the X direction of one to 32, however, it is not possible to increase the Y range, to this alter the program thus:

```

10 DIM A(33)
20 DIM B(33)
30 LET K = + 2
270 LET K = 32
580 FOR X=0 TO 33
Life
10 DIM A(14)
20 DIM B(14)
30 LET K = 13
40 LET L = 1
50 LET M = K
60 LET N = 1
70 INPUT X
80 IF X=0 THEN GO TO 250
90 PRINT X
100 INPUT Y
110 LET A(X)=NOT (A(X) AND 2**Y)
    AND (A(X) OR 2**Y)
120 IF X<K THEN LET K = X
130 IF X>L THEN LET L = X
140 IF Y<M THEN LET M = Y
150 IF Y>N THEN LET N = Y
160 CLS
170 FOR Y=M TO N
180 LET Z=2**Y
190 FOR X=K TO L
200 PRINT CHR$(52*((A(X) AND Z)/Z));
210 NEXT X
220 PRINT
230 NEXT Y
240 GO TO 70
250 CLS
260 LET G=K + NOT K = 1
270 LET K = 13
280 LET H=L - NOT L = K
290 LET L = 1
300 LET I=M + NOT M = 1
310 LET M = K
320 LET J=N - NOT N = K

```

(continued on next page)

(continued from previous page)

```

330 LET N = 1
340 FOR Y = I TO J
350 LET Z = 2**Y
360 FOR X = G TO H
370 LET A = 0
380 FOR Q = Y-1 TO Y+1
390 LET R = **Q
400 FOR P = X-1 TO X+1
410 IF A(P) AND R THEN LET A = A + 1
420 NEXT P
430 NEXT Q
440 LET B = NOT (A(X) AND Z) = 0
450 LET A = A + B
460 IF B AND A = 2 OR A = 3 THEN GO
TO 490
470 PRINT " ";
480 GO TO 550
490 LET B(X) = B(X) OR Z
500 PRINT "0"
510 IF X < K THEN LET K = X
520 IF X > L THEN LET L = X
530 IF Y < M THEN LET M = Y
540 IF Y > N THEN LET N = Y
550 NEXT X
560 PRINT
570 NEXT Y
580 FOR X = 0 TO 14
590 LET A(X) = B(X)
600 LET B(X) = 0
610 NEXT X
620 INPUT A$
630 IF A$ = " " AND NOT K L THEN GO
TO 250

```

## Thames pilot

ONE OF the attractions of a boating holiday is the escape from schedules and time-tables writes Tim Goldingham of Maidenhead, Berkshire. Once on the river, one becomes oblivious of the passage of time, and the half-hour spent waiting for the lock to open is simply an opportunity for the helmsman to dive into the ice-box for a cold beer.

Nevertheless, practical considerations cannot be ignored. How far can we travel in our week's holiday? If we travel downstream at six knots, and back up at four, where must we turn to be sure of returning by next week-end? How much fuel are we going to use?

Let us see how it works. The mysterious string of numbers at line 20 provides the elements of an array — I am indebted to Clive Davies of Cheltenham who contributed the subroutine at line 600 to the ZX-80 users' club magazine *Interface*.

Each three-digit element represents the time taken to pass between a pair of locks at a speed of one knot. It is calculated by reference to *The Thames Book* — recommended reading for all Thames cruisers — which gives the distance of each lock above Teddington in miles and yards.

Dividing the distance in yards by 2,027 — the number of yards in a nautical mile — and multiplying by 60 gives the number of minutes to cover the distance. Note, the groups of three figures are separated by spaces in the listing, for ease of reading but they must be keyed in as a continuous string with no spaces.

The subroutine at line 600 converts the string into numeric form, and each figure

is placed in position in the array. That takes an appreciable time, which accounts for the slight delay between keying RUN and the appearance of the first message.

You can check that you have keyed in the number string correctly by the following procedure:

- 1 Key in lines 1 to 60
- 2 Key in the subroutine — 600 to 650
- 3 Key in the following checksum routine:

```

100 LET A = 0
110 FOR X = 1 TO 22
120 LET A = Z(X) + A
130 NEXT X
140 PRINT A
150 STOP

```

- 4 'A' Should now be displayed as 6465. When you have this correct, you can carry on keying in the rest of the program, overwriting lines 100 to 150.

Having set-up the array, the program asks for the start and finish lock numbers. Note, they are not included in the calculation; that is, keying in 10 and 12 would give the time to pass from just above Shiplake to just below Whitchurch. If the journey is downstream, the figures are reversed by lines 240 to 260.

Lines 300 to 320 take care of the Thames Water Authority regulation which restricts cruising speed to seven knots.

Once input is complete, lines 420 to 460 sum the appropriate array elements and divide by the speed in knots to give the motoring time. Again taking the journey from Shiplake to Whitchurch, locks 10 to 12, we add elements 10 and 11, i.e., 288 and 348, to give 636 minutes. That is then divided by, say, five knots to give 127 minutes travelling time.

It remains to count the number of locks to be negotiated, and add the appropriate number of minutes for each. Lines 480 to 510 convert the total minutes to hours and minutes. Finally, the motoring time is multiplied by the hourly fuel

## TABLE

1	Teddington Lock
2	Sunbury Lock
3	Chertsey Lock
4	Bell Weir Lock
5	Romney Lock
6	Bray Lock
7	Cookham Lock
8	Temple Lock
9	Hambleden Lock
10	Shiplake Lock
11	Caversham Lock
12	Whitchurch Lock
13	Cleeve Lock
14	Day's Lock
15	Culham Lock
16	Sandford Lock
17	Osney Lock
18	King's Lock
19	Pinkhill Lock
20	Shifford Lock
21	Radcot Lock
22	Buscot Lock
23	Lechlade Bridge

## Program Variables

F Finish lock number

```

G Gallons per hour/total fuel consumed
H Number of hours
K Speed in knots
L Number of minutes in each lock
M Total of inter-lock times
S Start lock number
T Total motoring time — also used as temporary store at line 240
W Total elapsed time
Z Array: minutes to cover inter-lock gap @ 1 knot

10 DIM Z(22)
20 LET Z$ = "418 261 250 309 287 219 310
224 303 288 348 244 545 302 373 208 184
218 448 362 270 094"
30 FOR X = 1 TO 22
40 GO SUB 600
50 LET Z(X) = N
60 NEXT X
100 PRINT "START:▽▽▽▽ ";
110 INPUT S
120 PRINT S
130 PRINT "FINISH"▽▽▽ ";
140 INPUT F
150 IF F < 24 AND S < 24 THEN GO TO
190
160 CLS
170 PRINT "???"
180 GO TO 100
190 PRINT F
200 IF NOT F = S THEN GO TO 230
210 PRINT "???"
220 GO TO 100
230 IF F > S THEN GO TO 270
240 LET T = F
250 LET F = S
260 LET S = T
270 PRINT "KNOTS:▽▽▽▽ ";
280 INPUT K
290 PRINT K
300 IF K < 8 THEN GO TO 330
310 PRINT "MUST NOT EXCEED 7?"
320 GO TO 270
330 PRINT "MINS/LOCK:";
340 INPUT L
350 PRINT L
360 IF L < 60 THEN GO TO 390
370 PRINT "???"
380 GO TO 330
390 PRINT "GALLS/HR:▽";
400 INPUT G
410 PRINT G
420 LET M = 0
430 FOR I = S TO F - 1
440 LET M = Z(I) + M
450 NEXT I
460 LET T = M/K
470 LET W = T + (((2*(F-S)) - 1) * L)
480 LET H = 0
490 IF W < 60 THEN GO TO 530
500 LET W = W - 60
510 LET H = H + 1
520 GO TO 490
530 PRINT
540 PRINT
"TIME:▽▽▽";H;"▽HRS▽";W;-
"▽MINS"
550 PRINT
560 LET G = G * T/60
570 PRINT
"FUEL:▽▽▽";G;"▽GALLS"
580 STOP
600 LET N = 0
610 FOR I = 1 TO 3
620 LET N = (N*10 + CODE(Z$) - 28)
630 LET Z$ = TL$(Z$)
640 NEXT I
650 RETURN

```



## Super graphics

THE PROGRAM was written for the TRS-80, but it is very easily transferred to other microprocessors using the teletex or Z-80 graphics writes John Taylor of Orpington, Kent. The idea behind the program can be transferred to the other micros using, say, a 6502 chip, i.e., the Pet.

The program has been transferred to a Research Machines 380-Z without any problems. The idea behind Super Graphics is simple; having written a longish program on a small-memory machine; when the program is run, it very quickly fills and uses all of the available memory and demands and tries to use non-existent memory, finds it impossible, and crashes with an out-of-memory error.

As many programs use the graphics facility, they tend to occupy excessive amounts of memory and are often messy in listing form.

An example of that is, say, to display on the VDU the message:

HI, JOHN.  
in a diagonal line — below is a program for the TRS-80 to do:

```
10 CLS
20 READ A,B
30 IF A=1 THEN 999
40 PRINT ↵ A,CHR$(B);
50 GOTO 20
60 REM ** DATA **
100 DATA 0,191,1,140,2,191
110 REM 'H'
120 DATA 68,179,69,191,70,179
130 REM 'I'
140 DATA 136,160,137,132
150 REM ','
160 DATA 203,188,204,176,205,191
170 REM 'J'
180 DATA 271,191,272,179,273,191
190 REM 'O'
200 DATA 339,191,340,140,341,191
210 REM 'H'
220 DATA 407,191,408,164,409,191
230 REM 'N'
240 DATA 476,160
250 REM '.'
260 REM ** DUMMY DATA **
270 DATA -1,-1,-1,-1
999 GOTO 999
1000 END
```

There is another method of displaying graphics which uses less memory space and stores the graphics in a string. Taking the TRS-80 as an example, the TRS-80 stores its program, etc., from location 42E4 Hex onwards to FFFF Hex.

Knowing that, and that the numbers on most microcomputers between 80 Hex and FF Hex — 128-256 decimal — are the values of the reserved words, for example, 80 Hex = 128 decimal = "Reserved Word" (TRS-80) END.

The "Reserved Words" are stored in the program as these Hexadecimal numbers and not, as you might think at first, as one Hex number for every alphanumeric item they contain. So Random is stored as 134 and not 82,65,78,68,79,77 — ASCII codes. The reserved word when needed, as in list, is called up as a stored string and displayed as such.

Now to the graphics program the 134

**TANDY FORUM** is devoted to the Tandy TRS-80. Sometimes we will use it to pass on news about the TRS-80 but, above all, it is for users, and would-be users, of the well-established model I and now the new model II. With your tips, queries, moans and comments, this page can become a market-place for TRS-80 information.

corresponding to Random also corresponds to CHR\$(134) which is, for those who do not know to what CHR\$(134) corresponds, a white blob.

The next step was to find some way of telling the computer every time it met the special Random to print the white blob — not the word Random. That is done by poking the decimal number which corresponds to Random, 134, into a string, typically, A\$.

The first problem one meets is that you do not know where the computer has stored A\$ in the program, you do not need to know where A\$ is stored for display, i.e., the variable table.

One first fill A\$ with, say, 20 decimal points, you tell the computer to go and locate the 20 decimal points. When it has done that, you ask the computer to tell you the decimal location of the first one.

This program will perform that:

```
10 CLS: CLEAR 100
20 A=17000:REM ** APROX. 42E9
   HEX **
30 A$="....."
40 A=A+1
50 P=PEEK(A):Q=PEEK(A+1):R=
   PEEK(A+3)
60 REM ** APROX. METHOD OF
   FINDING THE —
70 REM ** —START OF A$ **
80 IF P=46 AND Q=46 AND R=46
   THEN 200
90 REM ** NOT FOUND **
100 GOTO 40
200 REM ** FOUND **
210 PRINT:PRINT
220 PRINT" A$ START = DECIMAL
   LOCATION ",A
230 PRINT:PRINT
240 END
```

That has told you where the decimal point is stored at the start of A\$ in the RAM, now change the ASCII number stored at that location.

When that is done, i.e., POKE A,X when X is in the range of 19 to 225 from 19-31 the cursor control graphics numbers are stored — only about four — i.e., 24 = backspace. Let us say x=43, then when the program was listed after the change, the first decimal point would be changed to a +. When one prints A\$, we find one + 19 decimal points.

Now that is interesting but it is not the final target. One tries POKE A, 134. When we print A\$ we have the white blobs and 19 decimal points. The listing of line 30 is interesting too, as:

```
30 A$="RANDOM....."
RANDOM.....
```

The first decimal point has been replaced by the reserved word Random — a swapping of reserved words. PRINT PEEK(A) will give the result of 134. A word of warning now. Do not edit the

string in any way. If you do try, the computer will realise that we have pulled a fast one and when you next print A\$ all you will obtain is:

RANDOM.....  
After poking the desired graphics into A\$, it is possible to delete the program and leave line 30 which contains A\$ which can then be incorporated into your program. The printing of A\$ will save memory space as all you will have is A\$ and not the code which produced it. That saving of memory space is vital in programs which display a good deal of graphics in a low-memory machine.

```
10 A$="....."
16 REM ** SET UP AS WITH ** *S **
18 REM ** PRINT TITLES AND CLEAR SCREEN **
28 CLS: CLEAR 100
25 PRINT:PRINT "SUPER GRAPHICS..":PRINT
26 PRINT "BY JOHN TAYLOR..":PRINT:PRINT
28 PRINT:"PLEASE WAIT..":PRINT
30 A$1200:REM ** APROX. START OF PROGRAMME
   STORAGE IN DECIMAL **
40 A=A+1
41 P=PEEK(A):Q=PEEK(A+1):R=PEEK(A+3)
45 REM ** TEST FOR "A" **
50 IF P=42 AND Q=42 AND R=42 THEN 55
54 GOTO 60
58 REM ** 42 IS ASCII FOR "A" **
60 CLS:REM ** INSTRUCTIONS **
70 PRINT:PRINT
90 PRINT:"SUPER GRAPHICS BY JOHN TAYLOR."
92 PRINT
95 PRINT:"PRESS 'G' FOR GRAPHICS."
97 PRINT:"PRESS 'S' FOR END."
99 REM ** THIS WILL DELETE THE PROGRAMME **
95 REM ** BUT WILL LEAVE AS FOR YOUR USE **
100 PRINT:"PRESS 'A' TO START PROGRAMMING."
108 PRINT:PRINT
110 REM ** GET A KEY **
115 I=INKEY$:IF I$="" THEN 115
120 REM ** SELECTION **
125 IF I$="G" THEN 90
130 IF I$="S" THEN 200
135 IF I$="A" THEN 999
150 REM ** A=SHIFT **
160 GOTO 110
170 REM ** WROING KEY - TRY AGAIN **
200 REM ** DISPLAY GRAPHICS **
210 CLS:PRINT:PRINT
215 PRINT:"SUPER GRAPHICS..":PRINT
220 REM ** INITIAL VALUES OF ARROW -
   ** AND GRAPHICS **
230 I=92:REM ** ARROW **
235 C=32:REM ** GRAPHICS **
240 REM ** INSTRUCTIONS **
250 PRINT:"PRESS 'F' FOR FORWARD."
255 PRINT:"PRESS 'B' FOR BACKWARD."
260 REM ** PRINT TITLE BLOCK **
270 PRINT:A$(5):CHR$(1):
272 PRINT:"(CHR$(1))"
275 PRINT:PRINT
280 REM ** GET A KEY **
290 I=INKEY$:IF I$="" THEN 290
300 IF I$="F" THEN 60
310 IF I$="B" THEN T=92:C=1:GOTO 350
320 IF I$="C" THEN T=91:C=1:GOTO 350
330 REM ** USING KEY **
340 GOTO 290
350 REM ** NAME C IN RANGE OF 32-191 **
360 IF C<32 THEN C=32
370 IF C>191 THEN C=191
380 GOTO 240
390 REM ** DISPLAY NEXT **
400 REM ** NOW TO POKE **
410 CLS
415 REM ** INSTRUCTIONS **
420 PRINT:"TYPE THE NUMBER OF LINES THE"
425 PRINT:"GRAPHIC VALUE IS TO BE USED, THEN THE"
430 PRINT:"ASCII NUMBER OF THE GRAPHIC."
440 PRINT:"TYPE 'QUIT' TO RETURN TO OPTIONS."
450 PRINT
455 REM ** DISPLAY CONSTANT INPUT **
465 PRINT:PRINT "STRING(130-131)"
468 PRINT:PRINT:PRINT
470 REM ** INPUT **
475 PRINT:PRINT "1"
480 INPUT:"TYPE THE NUMBER=ASCII VALUE":I$:N$
485 REM ** GET NUMBERS **
490 N=VAL(N$):I=VAL(I$)
495 N=INT(ABS(N)):I=INT(ABS(I))
500 IF I="" THEN "OR "N=QUIT" THEN 40
510 REM ** IF QUIT - RETURN TO OPTIONS **
520 REM ** GET M IN RANGE OF 13 TO 191 **
530 REM ** 13 TO 31 CURSOR CONTROL VALUES **
531 REM ** ON THE TRS-80 (LEVEL II) **
540 IF M<13 THEN PRINT:"ABOVE 13":GOTO 455
545 IF M>191 THEN PRINT:"BELOW 191":GOTO 455
550 REM ** GET T IN RANGE 1-250 **
555 IF T=0 THEN T=1
560 IF T>250 THEN T=250
570 REM ** THE POKE **
580 FOR D=1 TO T
590 IF PEEK(A+D) THEN 630
600 REM ** YOU WILL NOT BE ALLOWED TO POKE -
   ** INTO THE PROGRAMME - ONLY A$ **
610 POKE A+D
620 A=A+1:PRINT:"D.K."
625 C=C+9:REM ** GET NEXT NUMBERS **
630 CLS:REM ** OUT OF ROOM - END **
640 PRINT:"SUPER GRAPHICS..":PRINT:PRINT
650 PRINT:"YOU HAVE USED UP ALL OF YOUR STRING"
660 PRINT:"FOR THIS PROGRAMME IS NOW DELETED."
670 PRINT:"PRESS 'TYPE IN THE FOLLOWING:"
680 PRINT:" 20 PRINT A$"
690 PRINT:" 30 END"
695 PRINT:"TO SEE THE GRAPHICS WHICH YOU"
700 PRINT:"HAVE CREATED."
710 PRINT:PRINT:PRINT
800 REM
810 REM
820 REM
830 REM SUPER GRAPHICS
840 REM
850 REM BY .....
860 REM
870 REM JOHN TAYLOR.
880 REM
890 REM *****
900 REM
905 REM DELETE 16-999:END
```

**commodore**  
**PET PACK**  
**software**  
**DIRECT FROM**  
*audiogenic*

(WE MANUFACTURE THEM)

The Commodore range of Petpack Software is big and getting bigger! At the moment there are over 60 Petpacks and new programs are being added all the time. Here at Audiogenic we hold stocks of every Petpack and GD series disc, ready for immediate despatch.

For the Businessman we have programs for Stock Control, Filing, Accounts, Payroll, a very powerful Word Processor, and more!

For Educational applications we have programs to aid in the tuition of Languages, Physics, Maths, English, Pet Programming, Statistics, etc. For the Scientist or Engineer we have programs on Mechanics of Materials, Harmonic Analysis, Circuit Design, Drawing Load and Die Design, Statistical Analysis, Geometry and Algebra, to mention but a few. Then for the Programmer, there is a selection of Programming Aids on cassette and disc. And, of course, there are the Games Petpacks! Fun for all the Family! There are at present 12 cassettes in the Treasure Trove series, with over 40 different games in all. The Arcade series has 6 games which will be familiar to those of you who frequent pubs, clubs or amusement arcades. The games are PET versions of those popular pastimes like the addictive 'Space Invaders' or the universe-encompassing 3D Startrek.

**Get out catalogue for the exciting details.**

**LATEST NEWS ORACLE PAGE 451**

**NEW RELEASES**

Pascal (32k Pets Only) £138.00 Galaxy One-Combination of Treasure Troves 1 to 6 on Disk £46.00 Arcade Games — Breakthrough, Night Driver and Car Race £7.00 each 2 more Treasure Troves including Drive Bomber Dominos, L Game and Tower of Hanoi £10.00 each

Wordpro 1 (Old Rom Only) Cassette forerunner board pro 3: £25.00

Vegetable planner — Computing your garden £10.00  
 7 additions to our educational PETPACKS inc pilot and cesil @ £10.00 each

**BOOKS**

As well as PET releases and the 6500 hardware and Programming Manuals, we can offer from Osborne McGraw-Hill:-

**"PETCBM Personal Computer Guide" £9.95**

Everything you wanted to know about your "PET" — from "on" switch to the assembly language sub-routine

**"Some common basic programmes PET Editor" £8.70**

A collection of 76 practical BASIC programmes that address personal finance, with full PET listings, mathematical, statistical and general interest problems

**"PET and the IEEE 488BUS (GPIB)" £9.95**

This is the only complete guide available on interfacing PET to GPIB

**"6502 Assembly Language Programming" £8.70**

For the advanced programmer:- increase the capabilities and performance of PET

**ACCESSORIES**

"PETSET" to get you out of crashed conditions. Verbatim Disk £3 each 10 for £25.00 & Minkassette Disk Holders Blank Cassettes C10 5 for £2.75 and Printers Ribbons. Complete Range of Bib Cassette Accessories inc Head Demagnetiser @ £8.24

Post and Package 25p — Thereafter 10p for any additional items.

**P.O. Box 88 Reading, Berkshire,  
 Tel: (0734) 595269 24 Hour.**

• Circle No. 178

# Why get your PET from HSV

Because HSV are an established and expanding computing services company in operation since 1973. We offer microcomputers backed by systems advice, after-sales support and maintenance, from specialised computer centres.

Our interest does not stop at the sale of a PET — HSV assure full back-up support:-

- in-house analysts and programmers
- our own engineers operating from 2 service centres
- a range of specialist systems for business, industry and education
- instruction manuals, programme cassettes, add-on equipment and all other supplies

For Commodore PET 3000 and the new larger 8000 Series.

**That's why!**

HSV Limited, 22 Southampton Street, Southampton, Hants. Tel. (0703) 22131, and  
 May Place, Basingstoke, Hants. Tel. (0256) 62444.



• Circle No. 179

## ATTENTION PET & APPLE FLOPPY DISK USERS

Obtain up to TWICE the storage capacity from your 5.25" floppy disks. USE BOTH SIDES. Jig and tool to professionally modify your floppy disks + verification details to check out the "new" side. With disks at up to £30.00 for a box of 10 your savings on media cost are guaranteed. ONLY £12.50 per kit. (also suitable for other floppy users).

**ATTENTION COMMODORE PET USERS**

Now you can have permanently resident in memory any routine/program that you desire up to 2K. Your data taken from tape or disk that you supply is programmed into a 2716 5V EPROM ready for insertion into any 16K/32K type Commodore PET or 8000 series, or even into the 3040 disk unit. £21.00 including the 2716 EPROM.

**ALL PRICES QUOTED ARE FULLY INCLUSIVE**

**M.J. STONE  
 4 COSTERS CLOSE  
 ALVESTON, BRISTOL  
 TEL: (0454) 418015**

• Circle No. 180

## Superboard tips

I HAVE some tips which new users of the Superboard II may find useful writes Ian Bosworth of Aylesbury, Buckinghamshire.

When using a Peek instruction to look at the individual shift keys, e.g., for use in games, the shift-lock key must be up. If not, the operation of these keys will not be detected. ?CHR8 (10) and ? CHR8 (13) can be useful as line feed and carriage return respectively, as in the UK101 and Pet.

The command ?CHR8(13) is particularly useful in writing single-line instructions at the bottom of the screen diving games, or to produce flashing instructions — overprinting with spaces.

Shift K and shift M give 'J' and 'I' respectively on the keyboard — useful in scientific programs. Thank you very much for a very interesting magazine and for the tips in 6502 Special.

## Two oddities

THE implementation of Microsoft Basic on the Superboard is excellent, but I have discovered two oddities which can cause difficulties, writes Jack Pike of Chawston in Bedfordshire.

First, the list instruction when used in a program statement causes the program to end after obeying the list. That is annoying, and even CONT does not help continue the program execution. On other computers, such as the Apple in Applesoft, the list command is obeyed and the program execution continues.

Does anyone know how to arrange for the same thing to happen on a Superboard? One might Poke the warm-start location before the list command and return it to its correct value afterwards.

Secondly, have you ever tried POKE, N PEEK(N+1) as an instruction to make adjacent RAM locations have the same value? It does not work on the Superboard, neither does it cause a program failure. Try running the following program:

```
10 N = 1000
20 PRINT PEEK(N), PEEK(N+1)
30 POKE N, PEEK(N+1)
40 PRINT PEEK(N), PEEK(N+1)
```

If you replace line 30 with the equivalent Basic line:

```
30 P = PEEK(N+1): POKE N, P
all is well. Do the UK101 and the OSI C2 have the same problem?
```

## Scrolling messages

LOLL HOLT of Worsley, Lancashire has sent in a machine-code program for the Acorn System One. Its function is to present a stored message in scroll form he writes. Being totally re-locatable, it is perfect for providing messages during games, etc. Each message — several may be called by this routine, the only limit being zero-page memory — is stored in

**THE 6502 SPECIAL is dedicated exclusively to the exchange of information between 6502 users. It is up to you, the reader, to help establish this page with your ideas, problems and guidance for other 6502 users. Please mark your letters 6502 Special. We pay £5 for each contribution published.**

Hex code somewhere in zero-page.

The start-address of the message should be stored at 0020, and the finish-address at 0021. The scroll speed can be varied by changing the address labelled with an asterisk — the smaller the number, the faster the scroll.

```
A6 20 — set X
A9 1F — single scan
85 0E display
9A — save X
A2 10* — wait routine
20 0C FE
CA
DO FA
B5 11 — shift display
95 10 left routine
E8
E0 07
DO F7
BA — restore X
B5 00 — get new data
85 17 — display on left
E8
E4 21 — check for end of data
DO E4 — return to start
A9 FF
85 0E
4C 04 FF — end.
```

## Slowing listing

ANYONE with a Pupukit UK101 must find the speed of listing annoyingly fast writes M Phillips of Crewe, Cheshire. Too fast to be able to spot slight mistakes or to be able to find areas in the program to alter. By the time you have pressed Control/C, the area has disappeared from the screen.

To slow down the listing, it is necessary to Poke 518 — the CRT simulator baud rate — with a value of 0=fast to 255=low. Values of 50 or 100 are satisfactory in fault finding.

## Select logic

I HAVE been a reader of your magazine for a long time and in my opinion it is an excellent publication; please keep it up, writes B Mistry of Bradford, West Yorkshire.

I would like to offer your readers of the 6502 Special some ideas picked up while working on my Superboard II.

As some readers will know, the ACIA resides, not only, at F0000 and F001, it, in fact, occupies 128 locations, i.e., from F0000 and F0FF; that is due to page select logic. Anyone intending to put in a PIA or other hardware should note and keep clear of page F0.

Again, for hardware addition, why not use the logic available on the computer board for hardware additions, e.g., IC 23

plus 7 is the 'E' output — that is an 8K decode signal. In fact, IC 23 provides the following eight, 8Kbyte decode signals:

```
PIN 15 — 0000
PIN 14 — 2000
PIN 13 — 4000
PIN 12 — 6000
PIN 11 — 8000
PIN 10 — A000
PIN 9 — C000
PIN 7 — E000
```

As most will know, the Superboard has four scratch pads for 16 pin ICs which could be used or a small board with some 74 LS 138s or 139s for further decoding.

## Routine savers

IT IS possible to use Ritchie's routines published in May, 6502 Special to save full-length strings on tape by POKEing 15 with 255 writes Kevin Ford of Lincoln. That will prevent any spurious carriage returns being output to the tape and enable full use of those routines.

I must point out that my own routines which also appeared in May, 6502 Special were not designed specifically for saving variables; their main use is the saving of very long (2048 bytes) strings.

## Moving data

AFTER reading Toby Walsh's comments about moving data around the UK101 screen in the September issue, it occurred to me that a routine to shift all data down the screen might be as useful if not more so than using 'PRINT' writes B J Last of Llanfairfechan, Gwynedd.

This routine uses the spare page-zero locations at 0061 to 0064 and resides in the spare RAM at 0200H. It can be called by 'X=R(X)' after setting up the USR pointers by 'POKE 11, 34:POKE12,2'.

Address	Assembler	Code	OP codes
0222	LDA	#FF	A9 FF
0224	STA	0061	85 61
0226	LDA	#D3	A9 D3
0228	STA	0062	85 62
022A	LDY	#0	A0 00
022C	LDA	(61),Y	B1 61
022E	LDY	#32	A0 20
0230	STA	(61),Y	91 61
0232	DEC	61	C6 61
0234	LDA	0061	A5 61
0236	CMP	#255	C9 FF
0238	BNE	-16	D0 F0
023A	DEC	62	C6 62
023C	CMP	#CFH	C9 CF
023E	BNE	-24	D0 C8
0240	RTS		60

It is written for the Superboard II, but changing the LDY#32 at 022EH to LDY#64 will allow it to run on the UK 101.

# CODIFIED COMPUTER SYSTEMS

supply **British**  Micro computer systems, S100 IEEE cards and peripherals in London

In delightful Milton Keynes in beautiful Buckinghamshire a near genius, who sleeps too little and smokes too much, realised the obvious and designed the following set of S100 cards to IEEE timing specs. The brand is *Interactive*. The cards work well and we regret that not only is the chip count low (giving greater reliability and proving good design), but also there are no cut tracks or free soldered wire jumpers.

Z80 CPU	S100 4 MHz CPU card with remarkably few chips. A & T. £105.00
FDC	1791 (not unnecessarily DMA) floppy disc controller to handle any combination of 8" or 5" drives at single or double density. A & T. £198.00
16K SRAM	16K static RAM card using 2114's, (we look forward to the Mark II with 24 bit addressing). A & T. £198.00
SMBC	An S100 single board computer with Z80A, 1K RAM, up to 16K ROM, 2 RS232 (or 20mA) serial I/O and 4 channel counter/timer/vector interrupt. A & T. £235.00
PCI	Process control interface D/A, A/D 8 channels - output relay isolated, input opto-isolated. A & T. £235.00

If you convince us that you have the experience to put a kit together we will supply one at 20% off.

## The Codified floppy disc box

contains two DRI (made in Crewe) 7200 double-sided 8" drives giving 1.9mbytes at double density. There is room for two more inside. It is made of wood (genuine chipboard faced in oak veneer) by dedicated British workmen in Tottenham, and finished in tough acrylic varnish. It is supplied with 50 way connector, power supply and lead, mains filter (of course), illuminated on/off switch, fuses and large fan to BS3456. Price £1150.00

## Systems software peripherals

*Interactive* supply a very fair box with fan and power unit to hold their cards.

CP/M(TM) is available configured for their system.

Business software and a fine word processing system is available (written in Yorkshire) to those who need a simple but expandable solution to their problem. We have enough faith in it to use it ourselves!

Several very reliable ex-colleagues of the owners have left the mainframe computer rat-race and we will recommend them to analyse your problems and write bespoke software.

OEM's serviced in London area.

**Codified Computer Systems**  
15 Newington Green, London N16. Telephone 01-226 1319

VAT at 15% should be added to your order totals.

• Circle No. 181

# COMMANDER MICRO SYSTEMS

Specialists in English and American software for TRS-80 (Models I and II), Pet, Apple, and Heath. Widest selection in Europe, from such names as Instant Software, Software Exchange, Galactic, Misosys, Microsoft, T.P.G., etc. . . .

## TRS-80 MODEL 1 LEVEL 2

FS1 Flight Simulator with spectacular 3-D graphics	£ 14.00
Household Accountant	£ 6.50
Space Invaders!!	£ 7.50
Weather Forecaster	£ 6.50
Oracle-80 Business Forecaster	£ 75.00
IRV Programmable keyboard	£ 12.00
Adventures from	£ 7.50
TRS-80 MODEL II Editor/Assembler (Galactic Software)	£120.00

## PET

ISI Flight Simulator	£ 6.50
Trek - X	£ 7.50
Accounting Assistant	£ 6.50
Mortgage/Financier	£ 6.50
Electronic Eng Assistant	£ 6.50
Decorator's Assistant	£ 6.50

## APPLE

FS1 Flight Simulator with 3-D graphics	£ 14.00
Math Tutor I and II	each £ 6.50
Visicalc	£ 90.00
Accounting Assistant	£ 6.50
Sahara Warriors	£ 6.50

Subscriptions for Kilobaud and 80 Microcomputing - £21.00 p.a.

Software authors!! If you have any good software you wish distributed on a worldwide basis send it in for review.

Send for catalogue or any further details to: -  
Commander Micro Systems, 39 Bradley Road, Shard End, Birmingham B34 7RL.

ALL PRICES EXCLUDE VAT @ 15%

• Circle No. 182

### Interrupt routines

FOR ANYONE wishing to write their own interrupt routines for use on the Pet 16K or 32K models, here is my method writes Jeremy Cook of Leicester. Firstly, write your machine-code routine you wish to use as an interrupt and place it in a suitable area of memory such as the second cassette buffer — locations \$033A-\$03FF.

As an example, I am using a program to reverse every screen character and then reverse again every time a key is pressed creating a screen flash. The program is also shown in its assembler code.

```

BEG LDA $25
    BIT $97
    BEG FIN 1    check if key was
                  held down

    LDA $97
    STA $25
    LDA #$3FF
    BIT $97
    BEQ FIN 1    check in no key
                  was pressed

    JBR FLASH
    JBR FLASH
FIN 1 JMP BEG    loop round again
FLASH LDY #0
    LDA #0
    STA $23
    LDA #$80
    STA $24
START LDA ($23),Y
    EOR #$80
    STA ($23),Y
    INY
    BNE START
    LDA #$83
    BIT $24
    BEQ PIN 2
    JMP START
FIN 2 RTS

:033A A5 25 24 97 FO 10 A5 27
:0342 85 25 A9 FF 24 97 FO 06
:034A 20 53 03 20 53 03 4C 3A
:0352 03 AD 00 A9 00 85 23 A9
:035A 80 85 24 B1 23 49 80 91
:0362 23 C8 DO F7 A9 83 24 24
:036A FO 05 E6 24 4C 5D 03 60
    
```

The routine can then be tested with .G 033A with less chance of crashing the machine than if it was put into the interrupt straight away — of course you must save the program before any attempt to run by typing .S "FLASH", 01,033A,0372.

When the routine works correctly, you must incorporate it into the interrupt. That is reasonably easy. List the routine with .M 033A, 0372, then list the interrupt pointers with .M 0090, 0091.

```

.M 0090, 0091
:0090 2E E6. ....
Change the program to jump into the
interrupt rather than back to itself by
changing locations 0341 and 0342 to 2E
and E6 respectively — the numbers in
0090 and 0091 — then re-set the interrupt
pointers to the start of your routine so
that they read:
:0090 3A 03. ....
    
```

The screen should now flash at each keystroke but the machine will function correctly. In a completed program, instead of altering the interrupt pointers



by hand, they could be done easily by:

```

SEI 78
LDA #$3A A9 3A
STA $90 85 90
LDA #$03 AP 03
STA $91 85 91
CLI 58
    
```

### More from Pet

PHILIP DEAKIN of Alnwick, Northumberland, using simple illustrations, describes how to overlay a number of consecutive programs to allow the user to use more memory than his Pet possesses. Of course, there are difficulties but if the main principles are understood clearly, they can be dealt with and in practice, they are not as onerous as might first appear, he writes.

We shall illustrate the procedure using a trivial program which allows the user to select then print either the root, the square or the cube of the numbers one to 15 which are labelled with a program selected label. The program is split into five smaller programs which would run sequentially with a cassette but which could loop if discs were used.

The Peek and Poke addresses given in the programs are for the new ROMs but the equivalents for the old ROMs will be given at the end of the article.

As a program begins to use more and more memory, execution grows, slower and slower to the point where the delays become intolerable. It is at that point one wishes that the program could be split and run in more than one piece.

The program is that when one loads the second program, the variables calculated in the first are lost and although it is possible to carry a certain number over using the screen, that method is limited. So the problem is to load the second program while still retaining the variables and arrays determined in the first.

That is not too difficult because loading the second program does not destroy the variables and arrays, it merely re-sets the pointers which tells the program where they are. Now variables are stored immediately after the program and arrays, and the addresses of string arrays are stored immediately after that. So, the first rule must be that no subsequent program can be longer than the first, otherwise variable and array values would be overwritten.

To obtain maximum effect from the system all the constituent programs should be of equal size. That can be made much easier by deceiving the Pet into thinking that the program which calculates the variables and arrays is as long as the longest program in the set.

It is done by loading into decimal locations 42 to 49 the values which would be there if the largest program were loaded. If, for instance, the largest program were to finish at location 4096, locations 42, 44 and 46 would be poked with the value 0 while locations 42, 45 and 47 would be poked with the value 16 (16\*256 = 4096).

The next operation is to open the variable and array storage area to the maximum amount needed during the running of all the programs. First, declare all the variables and string variables by statements such as a=a:a\$a=a\$, etc. Then, dimension and calculate the values of all the arrays both string and numeric. Finally, we store the addresses of the now expanded storage locations in a convenient location in the second cassette buffer.

To do that we peek the address and poke it into the second cassette buffer. That information must be stored outside the normal program operating area, that is 1024 to the top of memory as these locations when can be changed new programs are loaded. The final step in this program is to load the next program and run it.

The listing of the first program called "P0" is:

```

10 poke42,0:poke43,16:poke44,0:poke45,16:
poke46,0:poke47,16
20 a$a=a$:i=i:k=k
30 dim x (15),y(15),/(15),a$(3)
40 for i=1 to 15
50 x(i)=sqr(i)
60 y(i)=i 2
70 z(i)=i 3
80 next i
90 a$(1)="root"+ " ":$(2)="square"+
" ":a$(3)="cube"+ " "
100 poke976,peek(42):poke977,peek(43):
poke978,peek(44):poke979,peek(45)
110 poke980,peek(46):poke981,peek(47):
poke982,peek(48):poke983,peek(49)
120 load "P1",1
    
```

Two other points about the program: firstly, the string variables have the null character " " added to them so that they will be stored at the top of memory. Otherwise the computer saves space by addressing them by their declared value within the program. That would, of course, be lost when the next program was loaded; secondly, if you are using discs, then line 20 becomes  
120 load "0:P1",8:run  
for Commodore discs and  
120 \$x,1,"P1"  
for the Computhink disc.

That loads the second program P1 which offers a choice or men. Lines 10 and 20 transfer the variable and array addresses back to the operating system. Lines 30 to 110 offer the options, while

(continued on next page)

(continued from previous page)

lines 120 to 150 load the appropriate option. The listing of "P1" is:

```
10 poke42,peek(976):poke43,peek(977):
poke44,peek(978):poke45,peek(979)
20 poke46,peek(980):poke47,peek(981):
poke48,peek(982):poke49,peek(983)
30 print"[cls]do you want—" :print :print
40 print"[rvs]r[rvo]oot" :print :print
50 print"[rvs]s[rvo]quare" :print :print
60 print"[rvs]c[rvo]ube" :print :print
70 print"[rvs]e[rvo]nd" :print :print
80 print" type option"
90 set a$:ifa$=" "then90
100 if a$="r" then k=1:goto140
110 if a$="s" then k=2:goto150
120 if a$="o" then k=3:goto160
130 if a$="e" then end
140 load"P2",1
150 load"P3",1
160 load"P4",1
```

If you are using discs, line 140 becomes  
140 load"O:P2",8:run, etc.  
for Commodore discs and  
140 \$x,1,"P2", etc.  
for Comphink discs.

That will load and run the program which prints on the screen your selection "P2", "P3" or "P4". Those programs are very similar — the only difference is the variable

```
x(i) in P2
y(i) in P3
z(i) in P4
```

Only "P2" will be given.

```
10 poke42,peek(976):poke43,peek(977):
poke44,peek(978):poke45,peek(979)
20 poke46,peek(980):poke47,peek(981):
poke48,peek(982):poke49,peek(983)
30 print"[cls]":print " x ",a$(k)
40 for i = 1 to 15:printi, x (i):nexti
50 print"to continue press [rvs]space[rvo]"
60 get a$:if a$ > chr$(32)then 60
70 end
```

That is where a simple cassette version would end. However, if a more complex system was required, that could be achieved by multiple recording of programs, i.e., if the cassette was recorded in the following sequence

```
"P0", "P1", "P2", "P3", "P4", "P1",
"P2", "P3", "P4", "P1", "P2", "P3", "P4"
```

If line 70 becomes  
70 load"P1"

The functions can be printed in any order. Using discs, the procedure becomes much simpler because only one recording of each program is necessary. Line 70 becomes

```
70 load"O:P1",8:run
for Commodore discs and
```

70 \$x,1,"P1" for Comphink discs.

The system is not so straightforward for old-ROM Pets as it is not possible to Poke a Peek. Thus, line 10 would become a = peek(976):b = peek(977), etc. and then a line 15 would have to be written.

15 poke124,a:poke125,b etc.  
The corresponding old ROM addresses to the new ROM ones given in the programs are

- 42 = 124
- 43 = 125
- 44 = 126
- 45 = 127
- 46 = 128
- 47 = 129
- 48 = 130
- 49 = 131

The screenprint of "P2", etc. shows that the variable k, the arrays x(i),y(i),z(i) and the string array a\$(k) have been carried over from program to program.

Here is all the information required to allow a much more complex set of programs to be built thus making maximum use of the capabilities of the Pet. What are the disadvantages?

Well, firstly, the programs have to be structured much more carefully, so they take longer to write. Secondly, loading, especially from cassettes, takes a considerable amount of time. However, there are many applications where that is not a serious disadvantage or where there is no other choice and so that technique allows us to put a gallon into a pint pot.

### Line append scan

A LISTING of Line Append Scan and Line Reference Scan written for the new-ROM Pet with a Programmers' Toolkit has been sent to us by Stephen Folmer of Grantham, Lincolnshire. To use both programs, re-number the user program starting at 0 with increments of 1. Append either program and type 'RUN 6300'.

Line Append Scan will avoid the possibility of appending a line to the previous and discovering at execution time that the line you have appended is either referenced or can never be executed. This program scans the user program and lists all the line numbers which can be appended safely.

A line cannot be appended to the

previous line when: the previous line contains STOP, END, GOTO, RETURN, REM, IF(THEN), LIST, ON GOTO; the line to be appended is referenced elsewhere by GOTO, THEN, GOSUB (ON GOTO, GOSUB).

The array T(1) to T(9) contains the token values of the statements mentioned in the first point. The reason why they cannot be stored in 'DATA' format is due to the possibility of data statements being present in the user program.

The program first determines the number of lines in the user program and dimensions array AR% according to the highest line number. Every element of array AR% refers to the program line number equal to its index. It is for that reason that it is necessary to re-number your program starting at 0 with increments of 1.

When an unappendable line is found, the array element indexed by the line number is set to -1. For each statement, the program first checks for a token value contained in array 'T', if found, the number will be flagged as unappendable (63014).

If the statement is a 'GOTO' or 'GOSUB', the line number referenced is dealt with similarly. The same applies if a line number follows a 'THEN' statement. If the 'ON' statement is found prior to a 'GOTO' or 'GOSUB', the line is scanned for further line references — token value of 'ON' = 145.

When the scanning is complete the appendable lines are listed on the printer. If you do not have a printer delete line 63021 and amend lines 63022 and 63023.

Line Reference Scan does nearly the opposite to the Line Append Scan though the logic is very similar. Each time a line is referenced, its corresponding AR% element is incremented by one. When the scan is complete, each line referenced is printed together with the number of references. The results can be used among other things to pin-point possible program inefficiency.

If desired, the two programs can be concatenated and run as one but care should be taken to add a 'CLR' statement between the programs and start line numbering with 63000.

### Line append scan and line reference.

```
READY.
63000 REM LINE APPEND SCAN#S.P.FOLMER#AUGUST 80#RENUMBER OTHER PROG 0.1#
63001 T(1)=128 T(2)=138 T(3)=155 T(4)=162 T(5)=142 T(6)=143 T(7)=144 T(8)=137
63002 T(9)=128 DEFFN(X)=PEEK(X+1):DEFFN(Y)=PEEK(X)+256#FNA(X):FI=-1
63003 LS=0:LP=40:PRINT" ":TAB(8):"*** LINE APPEND SCAN ***0000000000"
63004 LP=FNC(LP+2):LN=FNC(LP+2):OU=0:OG=0:CH=1
63005 IFFIANDLN=63000THENFI=NOTFI:DIRARZ(LS+1):GOTO63003
63006 IFFITHENLS=LN:GOTO63004
63007 IFLN=63000TO6301
63008 TP=LP+3:PRINT"PROCESSING LINE":LN;" ":LS=LN
63009 IFCH=0THENTP=TP+1:CH=PEEK(TP):IFCH=34THENOU=NOTOU
63010 IFCH=0GOTO63004
63011 IFOUGOTO63009
63012 IFCH=145THENOG=-1:GOTO63009
63013 IFCH=128ORCH=167GOTO63005
63014 FORI=1TO9:IFCH=T(I)THENARZ(LN+1)--I:I=9
63015 NEXT:RESTORE:IFCH<137ANDCH<141ANDCH<167GOTO63009
63016 CH=FNA(TP):CH=1:IFZ=32OR(OGANDZ=44)THENTP=TP+1:GOTO63016
63017 IFZ<48ORZ>57THENOG=0:GOTO63008
63018 NR#="" :FORI=TPTOTP+5:Z=FNA(I):IFZ>47ANDZ<58THENNR#NR#+CHR$(Z):NEXT
63019 ARZ(VAL(NR#))=-1:IFNOTOGGOTO63009
63020 TP=I+1:GOTO63016
63021 OPEN2,4,2:PRINT#2,"99999 3-0 9999 2-0"
63022 OPEN4,4,1:PRINT#4:FORI=1TOLS:IFARZ(I)>-1THENPRINT#4,I:
63023 NEXT:PRINT#4:CLOSE2:CLOSE4
READY.
63000 REM LINE REFERENCE SCAN#S.P.FOLMER#AUGUST 80#RENUMBER OTHER PROG 0.1#
63001 DEFFN(X)=PEEK(X+1):DEFFN(Y)=PEEK(X)+256#FNA(X):FI=-1
63002 LS=0:LP=40:PRINT" ":TAB(7):"*** LINE REFERENCE SCAN ***0000000000"
63003 LP=FNC(LP+1):LN=FNC(LP+2):OU=0:OG=0:CH=1
63004 IFFIANDLN=63000THENFI=NOTFI:DIRARZ(LS+1):GOTO63002
63005 IFFITHENLS=LN:GOTO63003
63006 IFLN=63000TO63018
63007 TP=LP+3:PRINT"PROCESSING LINE":LN;" ":LS=LN
63008 IFCH=0THENTP=TP+1:CH=PEEK(TP):IFCH=34THENOU=NOTOU
63009 IFCH=0GOTO63003
63010 IFOUGOTO63008
63011 IFCH=145THENOG=-1:GOTO63008
63012 IFCH<137ANDCH<141ANDCH<167GOTO63008
63013 Z=FNA(TP):CH=1:IFZ=32OR(OGANDZ=44)THENTP=TP+1:GOTO63013
63014 IFZ<48ORZ>57THENOG=0:GOTO63008
63015 NR#="" :FORI=TPTOTP+5:Z=FNA(I):IFZ>47ANDZ<58THENNR#NR#+CHR$(Z):NEXT
63016 ARZ(VAL(NR#))=ARZ(VAL(NR#))+1:IFNOTOGGOTO63008
63017 TP=I+1:GOTO63013
63018 OPEN2,4,2:PRINT#2,"99999 3-0 9999 2-0"
63019 OPEN4,4,1:PRINT#4:FORI=1TOLS:IFARZ(I)>0THENPRINT#4,I:ARZ(I):
63020 NEXT:PRINT#4:CLOSE2:CLOSE4
READY.
```

Comart Approved  
Cromemco Dealers

**Belfast**  
O & M Systems  
95 Dublin Road  
Contact: Richard Owens

**Birmingham**  
Byteshop Computerland Ltd  
94/96 Hurst St, B5 4TD  
Contact: Jim Attfield  
Tel: 021 622 7149  
Telex: 336186 BYTE G

**Cambridge**  
Cambridge Computer Stores  
1 Emmanuel St, CB1 1NE  
Contact: Claude Cowan  
Tel: 0223 68155

**Cornwall**  
Benchmark Computer  
Systems Ltd  
Tremena Manor  
Tremena Road  
St Austell, PL25 5GG  
Contact: John Fisher  
Tel: 0726 610000

**Dublin**  
Lendac Data Systems Ltd  
8 Dawson St  
Contact: Danny McNally  
Tel: 0001 372052

**Glasgow**  
Byteshop Computerland Ltd  
Magnet House  
61 Waterloo St, G2 7BP  
Contact: Gordon Coventry  
Tel: 041 221 7409  
Telex: 779263 BYTE GW G

**Leeds**  
Holdene Ltd  
Manchester Unity House  
11/12 Rampart Road  
Woodhouse St  
Contact: Jim Jackson  
Tel: 0532 459459  
Telex: 556319 HOLDEN G

**London**  
Byteshop Computerland Ltd  
48 Tottenham Court Road,  
W185 4TD  
Contact: John Braga  
Tel: 01 636 0647

Digitus  
9 Macklin Street  
Covent Garden WC2  
Contact: Alan Wood  
Tel: 01 405 6761

**Manchester**  
Byteshop Computerland Ltd  
11 Gateway House  
Piccadilly Station Approach  
Contact: Peter King  
Tel: 061 236 4737  
Telex: 666186 COMMAN G

NSC Computers  
29 Hanging Ditch  
Contact: Adam Wlseberg  
Tel: 061 832 2269

**Newbury**  
Newbear Computing Store  
40 Bartholomew St  
Contact: Tim Moore  
Tel: 0635 30505  
Telex: 848507 HJOLPN

**Nottingham**  
Byteshop Computerland Ltd  
92A Upper Parliament St,  
NG1 6LF  
Contact: David Clarke  
Tel: 0602 40576  
Telex: 377389 BYTEN0 G

**Sheffield**  
Hallam Computer Systems  
451 Eccleshall Road, S11 9PN  
Contact: Stuart Pulford  
Tel: 0742 663125

**Southampton**  
Xilan Systems  
23 Cumberland Place,  
SO1 2BB  
Contact: Geoff Lynch  
Tel: 0703 38740

**Sudbury**  
Eurotec Consultants  
Holbrook Hall  
Little Walsingham  
Contact: Dr Klimowicz  
Tel: 0206 262319  
Telex: 987248

**Warwicks**  
Business & Leisure  
Microcomputers  
16 The Square  
Kenilworth  
Contact: David Searle  
Tel: 0926 512127

Comart Microcomputer  
dealers are located  
strategically throughout the  
country to give support,  
guidance and assistance. In  
the event of difficulty contact  
Comart direct.

 **Cromemco**



## Flexibility + Versatility

### System Flexibility

Cromemco give you the high performance, reliable computer power you need now, with the in-built capability for future expansion and adaption as demands and requirements change.

The choice is wide. Cromemco's S-100 bus construction provides for expandable memory capability and the widest choice and future options in peripheral support.

Now there is the exciting range of Cromemco High Resolution Colour Graphics Systems.

### Applicational Versatility

Cromemco's CDOS Operating System supports proven, well documented Software for Business, Industry, Science, Research and Education; COBOL, RPG II, Macro Assembler, 16K and 32 BASIC, FORTRAN IV, LISP, RATFOR, Word Processing and Data Base, are all included in the range.

Now, there is the new CDOS compatible, Cromix Multi-user Multitasking Operating System which opens up new avenues in application and performance for Cromemco System Users.

The U.K. Leaders in Microcomputer  
Development, Application and Support.

**comart**

PO Box 2, St Neots, HUNTINGDON, Cambs  
Tel: (0480) 215005 Telex: 32514 Comart G.

• Circle No. 183

# Britain's first computer kit.

## The Sinclair ZX80.

# £79.95

Price breakdown  
 ZX80 and manual: £69.52  
 VAT: £10.43  
 Post and packing FREE

Please note: many kit makers quote VAT-exclusive prices.

You've seen the reviews... you've heard the excitement... now make the kit!

This is the ZX80. 'Personal Computer World' gave it 5 stars for 'excellent value.' Benchmark tests say it's faster than all previous personal computers. And the response from kit enthusiasts has been tremendous.

To help you appreciate its value, the price is shown above with and without VAT. This is so you can compare the ZX80 with competitive kits that don't appear with inclusive prices.

### 'Excellent value' indeed!

For just £79.95 (including VAT and p&p) you get everything you need to build a personal computer at home... PCB, with IC sockets for all ICs; case; leads for direct connection to a cassette recorder and television (black and white or colour); *everything!*

Yet the ZX80 really is a complete, powerful, full-facility computer, matching or surpassing other personal computers at several times the price.

The ZX80 is programmed in BASIC, the world's most popular computer language for beginners and experts alike.

The ZX80 is pleasantly straightforward to assemble, using a fine-tipped soldering iron. It immediately proves what a good job you've done: connect it to your TV... link it to an appropriate power source... and you're ready to go.

#### Your ZX80 kit contains...

- Printed circuit board, with IC sockets for all ICs.
- Complete components set, including all ICs—all manufactured by selected world-leading suppliers.
- New rugged Sinclair keyboard, touch-sensitive, wipe-clean.
- Ready-moulded case.
- Leads and plugs for connection to domestic TV and cassette recorder. (Programs can be **SAVEd** and **LOADed** on to a portable cassette recorder.)
- **FREE** course in BASIC programming and user manual.

#### Optional extras

- Mains adaptor of 600 mA at 9 V DC nominal unregulated (available separately—see coupon).
- Additional memory expansion boards allowing up to 16K bytes RAM. (Extra RAM chips also available—see coupon).

\*Use a 600 mA at 9 V DC nominal unregulated mains adaptor. Available from Sinclair if desired (see coupon).

### The unique and valuable components of the Sinclair ZX80.

The Sinclair ZX80 is not just another personal computer. Quite apart from its exceptionally low price, the ZX80 has two uniquely advanced components: the Sinclair BASIC interpreter; and the Sinclair teach-yourself BASIC manual.

The unique Sinclair BASIC interpreter offers remarkable programming advantages:

- **Unique 'one-touch' key word entry: the ZX80 eliminates a great deal of tiresome typing.** Key words (RUN, PRINT, LIST, etc.) have their own single-key entry.
- **Unique syntax check.** Only lines with correct syntax are accepted into programs. A cursor identifies errors immediately. This prevents entry of long and complicated programs with faults only discovered when you try to run them.
- **Excellent string-handling capability**—takes up to 26 string variables of any length. All strings can undergo all relational tests (e.g. comparison). The ZX80 also has string input-to request a line of text when necessary. Strings do *not* need to be dimensioned.
- **Up to 26 single dimension arrays.**
- **FOR/NEXT loops nested up to 26.**
- **Variable names of any length.**
- **BASIC language also handles full Boolean arithmetic, conditional expressions, etc.**
- **Exceptionally powerful edit facilities,** allows modification of existing program lines.
- **Randomise function,** useful for games and secret codes, as well as more serious applications.
- **Timer under program control.**
- **PEEK and POKE enable entry of machine code instructions,** USR causes jump to a user's machine language sub-routine.
- **High-resolution graphics with 22 standard graphic symbols.**
- **All characters printable in reverse under program control.**
- **Lines of unlimited length.**

### Fewer chips, compact design, volume production—more power per pound!

The ZX80 owes its remarkable low price to its remarkable design: the whole system is packed on to fewer, newer, more powerful and advanced LSI chips. A single SUPER ROM, for instance, contains the BASIC interpreter, the character set, operating system, and monitor. And the ZX80's 1K byte RAM is roughly equivalent to 4K bytes in a conventional computer—typically storing 100 lines of BASIC. (Key words occupy only a single byte.)

The display shows 32 characters by 24 lines. And Benchmark tests show that the ZX80 is faster than all other personal computers.

No other personal computer offers this unique combination of high capability and low price.

Z80 A microprocessor—new, faster version of the famous Z-80 microprocessor chip, widely recognised as the best ever made.

Sockets for TV, cassette recorder, power supply.

UHF TV modulator.

RAM chips.

SUPER ROM.

Clock.

Rugged, flush, Sinclair keyboard

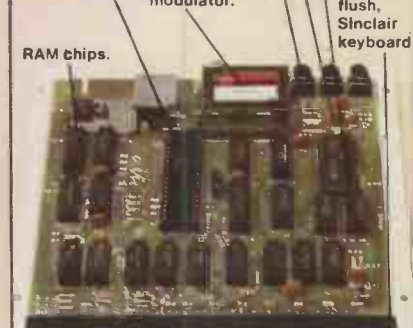



# plete

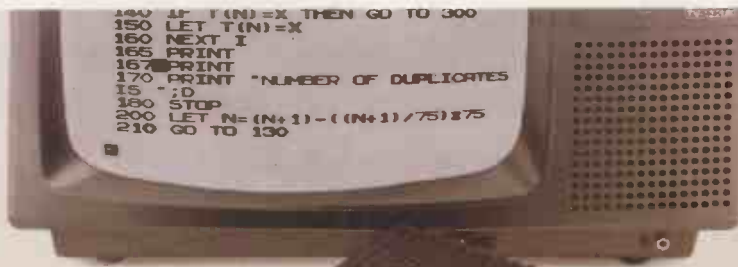

### The Sinclair teach-yourself BASIC manual.

If the specifications of the Sinclair ZX80 mean little to you - don't worry. They're all explained in the specially-written 128-page book free with every kit! The book makes learning easy, exciting and enjoyable, and represents a complete course in BASIC programming - from first principles to complex programs. (Available separately - purchase price refunded if you buy a ZX80 later.) A hardware manual is also included with every kit.

### The Sinclair ZX80. Kit: £79.95. Assembled: £99.95. Complete!

The ZX80 kit costs a mere £79.95. Can't wait to have a ZX80 up and running? No problem! It's also available, ready assembled and complete with mains adaptor, for only £99.95.

Demand for the ZX80 is very high: use the coupon to order today for the earliest possible delivery. All orders will be despatched in strict rotation. We'll acknowledge each order by return, and tell you exactly when your ZX80 will be delivered. If you choose not to wait, you can cancel your order immediately, and your money will be refunded at once. Again, of course, you may return your ZX80 as received within 14 days for a full refund. We want you to be satisfied beyond all doubt - and we have no doubt that you will be.

# sinclair ZX80

Science of Cambridge Ltd

6 Kings Parade, Cambridge, Cambs., CB2 1SN  
Tel: 0223 311488.

### ORDER FORM

To: Science of Cambridge Ltd, 6 Kings Parade, Cambridge, Cambs., CB2 1SN.  
Remember: all prices shown include VAT, postage and packing. No hidden extras.  
Please send me:

Quantity	Item	Item price £	Total £
	Sinclair ZX80 Personal Computer kit(s). Price includes ZX80 BASIC manual, excludes mains adaptor.	£79.95	
	Ready-assembled Sinclair ZX80 Personal Computer(s). Price includes ZX80 BASIC manual and mains adaptor.	£99.95	
	Mains Adaptor(s) (600 mA at 9 V DC nominal unregulated).	8.95	
	Memory Expansion Board(s) (each one takes up to 3K bytes).	12.00	
	RAM Memory chips - standard 1K bytes capacity.	16.00	
	Sinclair ZX80 Manual(s) (manual free with every ZX80 kit or ready-made computer).	5.00	

NB. Your Sinclair ZX80 may qualify as a business expense.

**TOTAL** £

I enclose a cheque/postal order payable to Science of Cambridge Ltd for £ \_\_\_\_\_

Please print

Name: Mr/Mrs/Miss \_\_\_\_\_

Address \_\_\_\_\_

PC11

• Circle No. 184

Make your micro

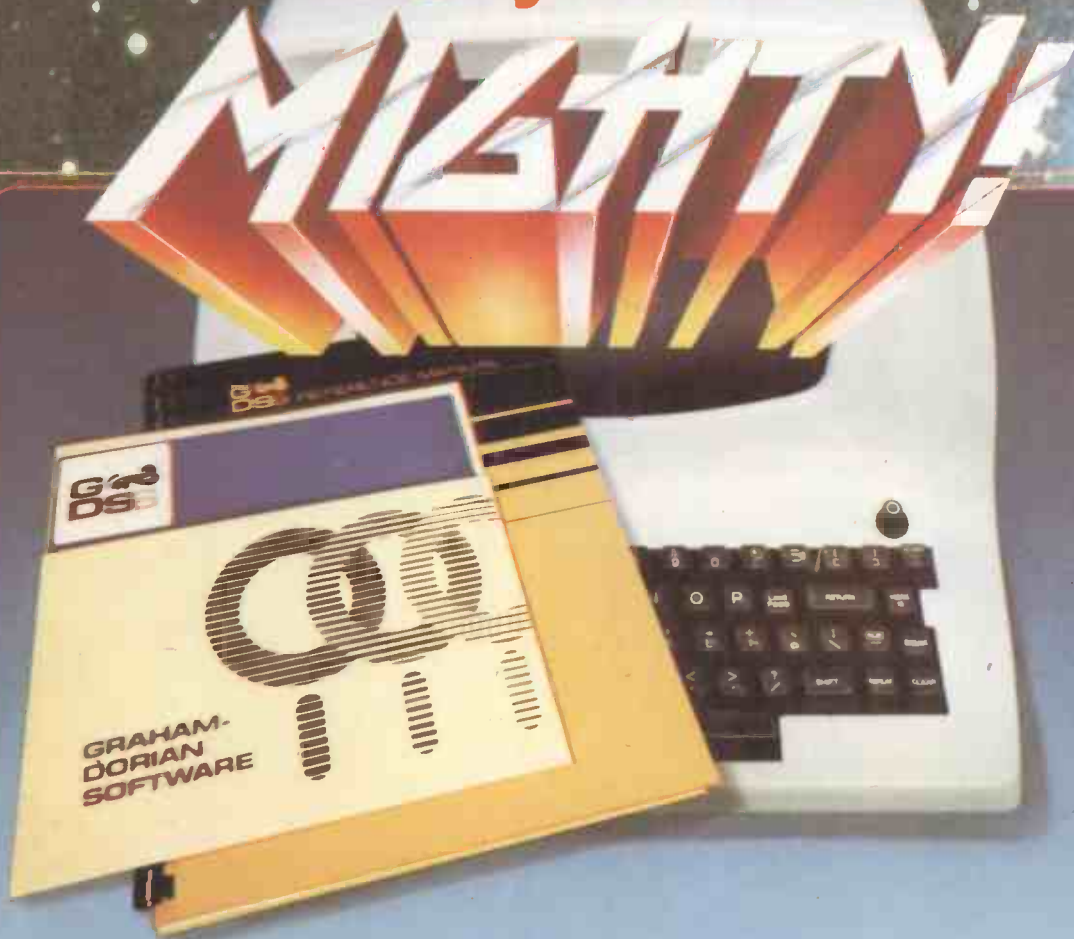

Get the most out of your microcomputer with Graham-Dorian Business software.

At any given time, your hardware is only as useful as the software you run in it. Our programs let you realise the full potential of your hardware

Graham-Dorian provides highly detailed and well documented programs. All pretested on the job. Each so comprehensive that it takes little time to learn to run a program — even for someone who's never operated a computer before.

Graham-Dorian programs are on-line now working for us and others around the world. They are ready to go to work immediately or to be tailored for your more specific needs. Each package contains a software program in BAS and INT film form plus a user's manual and hard copy SOURCE LISTING.

Programs are compatible with most major computers using CP/M disk operating systems, and come in standard 8" or on various mini-floppy disks.

Graham-Dorian stand behind dealers with technical advice.

Yes, there's a world of difference in business software. Graham-Dorian has more per-package capabilities and more packages (with new ones added every few months).

Distributors for Micropro:- Wordstar, Datastar & Mailmerge. CP/M for Tandy Model I & II

†GDSS are appointing UK Dealers and European Distributors. Enquiries and applications invited.

\*CBASIC-2 is a trade mark (copyright 1980) of Compiler Systems, Inc. GDSS are the European Distributor for CBASIC-2.

The Graham-Dorian line now includes these packages:

- Nominal Ledger
- Purchase Ledger
- Sales Ledger
- Job Costing
- Order Entry & Invoicing
- Payroll
- Manufacturing Inventory
- Manufacturing Job Costing
- Wholesaler Inventory
- Retailer Inventory
- Cash Register
- Apartment
- Surveying
- Dental

CBASIC-2\*

Ask your dealer for a demonstration soon.



Graham-Dorian Software Systems

A division of Graham-Dorian Enterprises & Terodec (Micro Systems) Ltd.  
Unit 58, Suttons Park Avenue, Earley  
Reading, Berks RG6 1AZ  
Tel (0734) 664345/6 GDSS

## Free-sector routine

I HAVE just received my copy of *Practical Computing* for July and can see no reference to errors in Roy Waldock's Free-Sector routine — Apple Pie, June writes R A Paganotto of The Hague in the Netherlands. May I, therefore, direct your attention to the ones I have found?

First of all, this useful little program does not always produce correct results. The oldest and ugliest bug in the history of loops has done it again: the byte at offset Hex 44 in the VTOC — the last byte meant to be tested by the loop — is missing altogether. In consequence, the program may report up to eight free sectors less than in fact are available. One way of curing that without upsetting the rest of the code is as follows:

Change \$BB into \$BC at location \$310

(i.e., LDX \$BB becomes LDX \$BC)

Change \$44 into \$43 at location \$312

(i.e., LDA \$2044,X becomes LDA \$2043,X)

Second, if one runs the program and subsequently types 3D0G from the Monitor to return to Basic via DOS, strange things happen. Which particular component of the system software — DOS, FP or the monitor — has the hiccups, I do not know as I do not have a printer and chasing that kind of bug on the screen is no fun.

Perhaps it is not even a bug but an undocumented feature of the software. I do know, however, what causes the problem and how to obviate it with no noticeable ill effects.

The RWTS routines leave the saved status register at location Hex 48 with the D,V and I flags on. Clearing them individually seems to either have no effect or make the problem much worse — a DOS boot is one of the things which might happen — but clearing all three seems to do the trick, i.e., store a zero in Hex 48. Does anyone know where to obtain an annotated listing of DOS 3.2?

## Three programs

THREE machine language programs for the Apple II have been submitted by Greg Watson of Chester. The first removes all lines beginning with REMs from an Applesoft program, the second is a machine-language re-locator, and the third a slow list utility for any Apple language.

For the REM Stripper program, type in the routines as shown, from \$300 to \$3E3. Note: the dollar sign indicates Hexadecimal numbers, the hash symbol indicates the immediate mode. Once the routines are in memory, save them with \*300.3FFW from monitor. Once your Applesoft program — the routines may work with Palsoft — is resident in RAM, the routines can be used by either: from Applesoft: ] CALL 768; from Monitor: \*300G. The very last line of the program must not be a REM. If the line does not begin with a REM, i.e., the REM follows a colon, the line will not be removed.

This section is open to the Apple user. In every issue we hope to print ideas, hints and comments about the Apple and its suppliers. They must come from you, so write and tell us what you know.



\$0300-DA	CLD		
301-A9 00	LDA #\$00	;INITIALISE	
		POINTERS	
		TO	
303-85 06	STA \$06	;START OF	
		PROGRAM	
305-A9 08	LDA #\$08	;AT \$0800	
307-85 07	STA \$07		
309-A0 00	LDY #\$00	;BEGINNING	
		OF LOOP	
30B-B1 06	LDA (\$06),Y		
30D-D0 71	BNE \$380	;SEARCH	
		FOR	
		INDICA-	
		TION	
30F-A0 05	LDA #\$05	;OF A REM	
311-B1 06	LDA (\$06),Y		
313-C9 B2	CMP #\$B2	;IS IT A	
		REM	
315-D0 69	BNE \$380	;NO, SO	
		INCREMENT	
		COUNTER	
317-20 B0 03	JSR \$3B0	;YES, SO	
		GET LINE	
		LENGTH	
31A-18	CLC		
31B-A5 06	\$06	;SET UP	
		THE	
		MEMORY	
		MOVE	
31D-69 01	ADC #\$01	;LOCATI-	
		ONS TO	
31F-85 42	STA \$42	;MOVE SUB-	
		SEQUENT	
		INES	
321-85 08	STA \$08	;ON TOP OF	
		THE	
323-A5 07	LDA \$07	;REM, THUS	
325-69 00	ADC #\$00	;EFFEC-	
		TIVELY	
		DELETING	
		IT	
327-85 43	STA \$43		
329-85 09	STA \$09		
32B-A0 01	LDY #\$01		
32D-B1 06	LDA (\$06),Y		
32F-85 3C	STA \$3C		
331-C8	INY		
332-B1 06	LDA (\$06),Y		
334-85 3D	STA \$3D		
336-A5 69	LDA \$69		
338-85 3E	STA \$3E		
33A-A5 6A	LDA \$6A		
33C-85 3F	STA \$3F		
340-20 2C FE	JSR \$FE2C	;PERFORM	
		THE MOVE	
343-EA	NOP		
344-A0 00	LDY #\$00	;WAS THE	
		LAST LINE	
		MOVED	
		DOWN	
346-B1 08	LDA (\$08),Y	;THE LAST	
		IN THE	
		PROGRAM?	
348-D0 03	BNE \$34D	;NO, SO	
		CONTINUE	
34A-4C D0 03	JMP \$3D0	;YES, SO RE-	
		SET	
		LOMEM:	
34D-A0 00	LDY #\$00	;REPLACE	
		THE OLD	
34F-B1 08	LDA (\$08),Y	;LINE	
		POINTERS	
351-38	SEC	;WITH NEW	
		ONES	
352-E5 0A	SBC \$0A	;WHICH	
		ALLOW	
354-85 0B	STA \$0B	;FOR THE	
		MISSING	
		REM	
356-C8	INY		
357-B1 08	LDA (\$08),Y		
359-E9 00	SBC #\$00		
35B-85 0C	STA \$0C		
35D-A0 00	LDY #\$00		
35F-A5 0B	LDA \$0B		
361-91 08	STA (\$08),Y		
363-C8	INY		
364-A5 0C	LDA \$0C		
366-91 08	STA (\$08),Y		
368-A5 0B	LDA \$0B		
36A-85 08	STA \$08		
36C-A5 0C	LDA \$0C		
36E-85 09	STA \$09		
370-4C 43 03	JMP \$343	;DO THE	
		NEXT LINE.	
\$0380-E6 06	INC \$06	;UPDATE	
		COUNTER	
382-A6 06	LDX \$06		
384-E0 00	CPX #\$00	;IS LOW	
		BYTE = 00?	
386-D0 09	BNE \$391	;NO, SO GO	
		TO LOOP	
388-E6 07	INC \$07	;YES, SO	
		INCREMENT	
		HIGH BYTE	
38A-A6 07	LDX \$07		
38C-CA	DEX	;DOES HIGH	
		BYTE = END	
		OF	
		PROGRAM?	
38D-E4 6A	CPX \$6A		
38F-F0 03	BEQ \$394	;YES, SO	
		RETURN	
391-4C 09 03	JMP \$309	;NO SO	
		GOTO LOOP	
394-60	RTS	;ALL DONE	
\$03B0-A2 06	LDX #\$06	;SET	
		POINTERS	
		TO	
3B2-A0 06	LDY #\$06	;INITIAL	
		SEARCH	
		AREA	
3B4-B1 06	LDA (\$06),Y	;GET BYTE	
3B6-F0 05	BEQ \$3BD	;IS IT ZERO	
		(END OF	
		LINE)	
3B8-E8	INX	;NO, SO GO	
		AGAIN	
3B9-C8	INY		
3BA-4C B4 03	JMP \$3B4		
3BD-86 0A	STX \$0A	;YES, SO	
		STORE LINE	
		LENGTH	
3BF-60	RTS	;AND	
		RETURN	
\$03D0-38	SEC	;RE-SET	
		END OF	
3D1-A5 69	LDA \$69	;PROGRAM	
		POINTERS	
3D3-E5 0A	SBC \$0A	;TO	
		CORRES-	
		POND	
3D7-85 AF	STA \$AF	;WITH	
		'ADJUSTED'	
		PROGRAM	
3D9-A5 6A	LDA \$6A	;ELSE A	
		MESS	
		WOULD	
		RESULT	

(continued on next page)

(continued from previous page)

```
3DB-E9 00 SBC #300
3DD-85 6A STA $6A
3DF-85 B0 STA $B0
3E1-4C 09 03 JMP $309 ;FINE, SO
GO TO
LOOP
```

I have often wanted to move a machine-language program to another portion of memory, for example, the 6502 assembler which is only resident in the integer ROM and not the Applesoft ROM. However, I often did not because it meant that many absolute addresses within the program had to be changed.

The next program allows you to move a program up and down in memory and alters the appropriate absolute addresses to be compatible with the new location.

Only move whole pages of memory — Page three, for example is \$0300 to \$03FF — into equivalent whole pages. While that may not be essential in some cases, it may make a difference in others, i.e., in terminology of the monitor move,

```
1000<F000.F4FFM YES
1000<F000.F457M NO
1000<F010.F4FFM NO
1020<F000.F4FFM NO
```

To use place present before move, start address in \$10(LOW) and \$11(HIGH), end address, present, in \$12(LOW) and \$16(HIGH) and then from the monitor \*300G(RETURN).

If, after 10 seconds, the cursor does not reappear then the program has crashed. The re-locator may interpret data as part of a program, and alter it subsequently. To avoid that, keep data separate, or else move it after the re-locator has been run. You do not do the move, the routines perform it.

```
$0300-D8 CLD
301-A2 08 LDX #308 ;SET UP
POINTERS
303-A0 00 LDY #300 ;FOR THE
MOVE
305-B5 0F LDA $0F,X
307-95 3B STA $3B,X
309-CA DEX
30A-D0 F9 BNE $305
30C-20 2C FE JSR $FE2C ;THEN DO
THE MOVE
30F-A5 16 LDA $16 ;INITIALISE
COUNTER
311-85 06 STA $06
313-A5 17 LDA $17
315-85 07 STA $07 ;WHAT IS
THE
317-38 SEC ;DIFFER-
ENCE
318-A5 11 LDA $11 ;BETWEEN
THE
31A-E5 17 SBC $17 ;LOCA-
TIONS, SO
31C-85 09 STA $09 ;I KNOW
WHAT
31E-38 SEC ;TO SUB-
TRACT
31F-A5 13 LDA $13 ;WHEN (IF) I
321-E5 09 SBC $09 NEED TO
CHANGE
323-85 15 STA $15 ;A BYTE
325-A9 FF LDA #$FF
327-85 14 STA $14
329-A0 00 LDY #300 ;GET A
BYTE
32B-B1 06 LDA ($06),Y
32D-20 8E F8 JSR $F88E ;DOES
THAT
OPCODE
```

```
330-A5 2F LDA $2F ;HAVE 3
BYTES?
332-C9 02 CMP #302
334-F0 07 BEQ $33D ;YES
336-AA TAX ;NO, SO
STORE
337-E8 INX ;HOW
MANY
BYTES
338-86 0A STX $0A ;IT DOES
HAVE
33A-38 SEC ;IN $0A
33B-B0 23 BCS $360 ;AND
INCREMENT
COUNTER
33D-A0 03 LDY #303 ;CHECK TO
SEE
33F-84 0A STY $0A ;WHETHER
OR NOT
341-88 DEY ;THE HIGH
BYTE
342-B1 06 LDA ($06),Y ;IS WITHIN
THE
344-85 0B STA $0B ;BOUND-
ARIES OF
346-C5 11 CMP $11 ;THE MOVE
348-30 16 BMI $360 ;IF IT ISN'T
34A-C5 13 CMP $13 ;THEN
GOTO 360
34C-F0 03 BEQ $351
34E-10 10 BPL $360
350-38 SEC ;IT IS, SO
LET'S
351-EA NOP ;MAKE THE
352-38 SEC ;APPRO-
PRIATE
353-E5 09 SBC $09 ;CHANGES
TO IT
355-A0 02 LDY #302 ;AND PUT
IT
357-91 06 STA ($06),Y ;BACK
WHERE IT
359-4C 60 03 JMP $360 ;WAS, AND
KEEP
GOING
$0360-18 CLC ;UPDATE
COUNTER
361-A5 0A LDA $0A ;AND
REPEAT
363-65 06 ADC $06 ;PROCE-
DURE
365-85 06 STA $06 ;COUNTER
IS
367-A5 07 LDA $07 ;GREATER
THAN
369-69 00 ADC #300 ;END
LOCATION
36B-85 07 STA $07 ;OF MOVED
36D-C5 15 CMP $15 ;PROGRAM
36F-30 B8 BMI $329
371-F0 B6 BEQ $329
373-60 RTS ;IF SO,
THEN END
```

Here is a slow list routine for the Apple. It works through adjusting the pointers to the COUT routine. What is the COUT routine? Every character printed-out to the TV by the Apple goes through the routine, which is part of the monitor. The routine starts at \$FDED and does an indirect JMP — jump which is the equivalent of the BASIC GOTO statement — to \$36.

That is, it looks at the two bytes stored in \$36 and \$37 and continuous running at that address. For example, in a non-disc based system, \$36 is usually the Hex value F0 and \$37 contains FD. The high byte — most significant — is in \$37 so in this case, the computer jumps to FDFO.

Now, if we change the values stored in \$36 and \$37 to point to our own routine, whenever the computer tries to print a character to the screen, it will have to go

through the routine we have inserted. The routine saves the 6502 registers, performs a short wait, checks to see if you have hit a return (Control M), and then returns to the computer control which prints the character.

The routines are in the form of three short programs, one which alters \$36 and \$37 to point to our routine while saving the old pointers — which I believe are different for a disc system — the second which restores \$36 and \$37 to their original values, and the third which performs the wait.

If you hit return while the routines are in operation, and the computer is printing something, it will stop and return to integer Basic. That is useful if you want to interrupt a long listing.

If you are using Applesoft, type the routines as shown, but then, from Applesoft, type in:

```
POKE831,0:POKE 832,0(RETURN),
and the program will go to Applesoft
instead of integer when it encounters a
return.
```

The wait between each character printed is determined by paddle 0. If you would rather use paddle X, type: from either Basic: POKE 804,X; from the monitor: \*324:X.

These routines cannot be re-located by changing the absolute addresses. The values used to replace those in \$36 and \$37 must point to the beginning of the wait section. If that is done, the program may be re-located. Once the routines are all there to use them: To turn on the routines on from Basic: CALL800; from Monitor: \*300G. To turn off the routines: from Basic: CALL785; from Monitor: \*311G.

```
$0300-A5 36 LDA $36 ;RE-SET
COUT
302-85 06 STA $06 ;HOOKS TO
POINT
304-A5 37 LDA $37 ;TO
PROGRAM
306-85 07 STA $07 ;SAVING
OLD
308-A9 20 LDA #320 ;HOOKS IN
30A-85 36 STA $36 ;$6 AND $7
30C-A9 03 LDA #303
30E-85 37 STA $37
310-60 RTS ;RETURN
$0311-A5 06 LDA $06 ;RESTORE
OLD
313-85 36 STA $36 ;COUT
HOOKS
315-A5 07 LDA $07 ;FROM $6
AND $07
317-85 37 STA $37
319-60 RTS
$0320-20 4A FF JSR $FF4A ;SAVE 6502
REGISTERS
323-A2 00 LDX #300 ;X =
PADDLE
NUMBER
; Y = 0
325-A0 00 LDY #300
327-20 1E FB JSR $FB1E
32A-98 TYA
32B-20 A8 FC JSR $FCA8
32E-AD 00 C0 LDA $C000
331-2C 10 C0 BIT $C010
334-C9 8D CMP #38D
336-F0 06 BEQ $33E
338-20 3F FF JSR $FF3F
33B-6C 06 00 JMP ($0006)
33E-4C 03 E0 JMP $E003 ;SOFT
START INTO
INTEGER
BASIC
```

# THE SOFTWARE WORKSHOP

SYSTEMS AND PROGRAMS FOR APPLE & ITT COMPUTERS.

## PAYROLL MASTER

THE FIRST OF A NEW BREED OF COMPUTER PROGRAMS FOR THE PROFESSIONALS.  
CONTAINS ALL THE FEATURES YOU EXPECT FROM A PAYROLL SYSTEM AND MANY MORE: -

- ALL TAX AND NATIONAL INSURANCE CALCULATIONS CARRIED OUT AUTOMATICALLY.
- 4 HOURLY RATES OF PAY - OVERTIME RATES - LUMP SUM PAYMENTS MADE AUTOMATICALLY - 5 ADJUSTMENTS BEFORE TAX - 5 ADJUSTMENTS AFTER TAX
- WEEKLY, MONTHLY AND TWO WEEKLY PAYROLL.
- PENSIONS CALCULATED AUTOMATICALLY. (WHEN REQUIRED)
- MOST TYPES OF BONUS CALCULATIONS AND PAYMENTS CATERED FOR.
- EASY TO READ PAYSLEIPS WHICH SHOWS YOUR COMPANY NAME.
- PASSWORD.
- PERFECTED AND TESTED BY EXPERIENCED EMPLOYERS AND OFFICE STAFF.
- SOFTWARE INSURANCE PLAN. (RENEWABLE ANNUALLY): - THIS ENSURES THAT WHEN YOU NEED HELP YOU GET IT. ALSO INCLUDES FREE UPDATE DISKS WHEN THE TAX AND NATIONAL INSURANCE RATES CHANGE. (REGARDLESS OF THE NUMBER OF CHANGES)
- EXCELLENT DOCUMENTATION.
- MANY MORE FEATURES.

### PRICES

PAYROLL MASTER. (INCLUDING MANUAL)	£200.00
SOFTWARE INSURANCE PLAN (1st YEAR)	£70.00
PAYSLEIPS (PER THOUSAND)	£19.50

### APPLE DOC

SURCHARGES FOR STRINGS/VARIABLES TO LIST, REPLACE ETC  
- LIST LINES THAT ARE DEPENDANT ON OTHER LINES  
MANY MORE FEATURES - GOOD DOCUMENTATION

£24.95

### DISK UTILITY

REPORTS ON THE NUMBER OF FREE SECTORS ON A DISK  
- DISK ERRORS ETC - SPECIAL COPY PROGRAM.  
MANY MORE FEATURES - GOOD DOCUMENTATION

£20.00

PLEASE CONTACT US FOR FURTHER DETAILS

TELEPHONE NUMBER: 0704 43038

70 SUSSEX ROAD  
SOUTHPORT  
MERSEYSIDE PR9 0SP

ALL PRICES EXCLUDING V.A.T.

• Circle No. 185

# SHARP MZ-80K SOFTWARE



TRADE ENQUIRIES WELCOME

## For Games Business Education

Send now for our  
FREE CATALOGUE

## MAP-21 LTD

9 Herbert Road, London N11

Tel: 01-889 7615 (24 hours)

• Circle No. 186

## Small Business Programs

By S Roberts, published June 1980 by Elcomp Publishing, 3873L Shaefer Avenue, Chino, CA 91710, USA. 117 pages, paperback, ISBN 3 — 921682 — 57 — 6. \$14.90.

SMALL Business Programs aptly describes the contents of this book; most of the 32 programs included are less than 100 lines on basic; the longest is less than 200 lines.

It is hard to imagine a viable business so small that the programs would be of much use; the programs seem trivial, inflexible and poorly documented. It is unlikely that any business would be able to use them without extensive customisation, and that would probably be harder than writing completely new programs.

For example, consider the payroll program on page 42. It is a program which contains the employee records as data statements, takes in details of hours worked and prints a 10-line payslip. No files are maintained.

The pay is calculated on the assumption, embedded in the Basic code, that hours worked over 40 are overtime at one-and-a-half times the standard pay-rate. Tax is calculated by assessing into which of five tax bands, 0 percent to 25 percent, the gross salary falls.

No provision is made for allowances, for PAYE complexities, or for deductions before tax, such as super-annuation. The tax bands are built into the Basic. No provision is made for national insurance.

The program does no checking for reasonable bounds on hours worked, or for double entry of the same employee number. Only one REM is included, to identify the loop to be changed if you have more than 4 employees. No mention is made of the fact that more than 20 employees will crash the program. There are six lines of documentation.

The 32 program listings are preceded by an article introducing the use of computers in small businesses. It is a mixture of useful information, prejudice and jargon, and is far more likely

to repel business enquirers than to encourage them.

The style of the article is appalling, the spelling more appropriate to The Molesworth Guide to Computers than to a serious book. Even on the cover "Programmer" is spelt with only one "m".

The best use for the programs would be to add realism to children's games of shops or hotels although, since the programs have been written for five different machines, many will need modification before they will run on your available hardware. The serious businessman or businesswoman should seek professional advice about the pitfalls and benefits of introducing computers into a company's operations.

### Conclusions

- Not recommended for any category of reader.
- There are far better books available.

Martyn Thomas

### The computer users' year book 1979 and international directory of software, 1980-81.

Published by CUYB Publications Ltd., 29 Queen's Road, Brighton, BN1 3XA. £32.95 for 1980 edition of CUYB, and £36; 1,206pp and 1,105pp respectively.

AT THEIR price, these are clearly expensive volumes. However, computing is an expensive game and it may well be worthwhile spending several pounds for information which will avoid expensive mistakes or enable you to find the best software.

It is too easy to spend several \$100 on the wrong piece of software just because you did not know that the better one was available.

Both tomes are heavy and handsome. They look good on your shelves beside the software manuals, but how much use are they to the microcomputer owner? The answer must be: not much for the average user, although they may be useful for the computer professional.

The micro user or would-be user needs to have ready access



to information about what to buy, where to buy, and who is offering what services. Both books have been designed for the mainframe professional and do not address themselves much to the problems of the micro user.

The topics treated in the CUYB which could be interesting for micro users and which is only a small part of the whole volume are: training facilities and courses, computer literature, computer journals, guide to computers and peripherals — very incomplete on micros in the 1979 edition, — guide to business equipment suppliers, consultants and systems houses, and so on.

The Directory of Software, again aimed primarily at large computer users, has sections on systems software and on application software which it lifts by function and it contains profiles of software suppliers.

While there is some useful information for the micro user, the information is nowhere near comprehensive. For instance, I could not find references in the index to CBasic, CP/M, Wordstar, Selector III, or VisiCalc, all of which are major programs for microcomputers.

If you were looking for something less run-of-the-mill, you would be unlikely to find it. The lay-out makes it laborious to search for software to run on a particular machine.

Both books face the problem of the rapid development in computer systems, particularly in microcomputers. The books are published three to nine months after the information is made available to the publishers.

Therefore, almost by definition, the best software in

the microworld, which will often have become available over the past year, will not appear in the manuals. The new version of the CUYB, published in September, will doubtless represent the microfield better. Yet, the Software Directory is going to be very out of date for micros by the time a new one is published in 1982.

The publishers also have a big problem in keeping track of all the vendors and distributors of microcomputer systems and software. If they try to be comprehensive, they will provide so much information that it becomes impossible to select it usefully. If they try to be selective, they may omit useful information.

Perhaps what is needed are a version of the books designed specifically for the micro-market. The basic concept is hard to fault: both books are well laid-out. They have very good access to their information through their indices, and considering the range of information they contain, it is surprising how easy it is to find the information you want.

Yet the average micro user is not likely to find enough information there to make them worthwhile. It may be possible to refer to them at your local public library or at a library attached to your local university or polytechnic. They are also available, along with much else, including manufacturers' leaflets and information, at the Science Reference Library Division of the British Library, 25 Southampton Buildings, WC2. That library, which incidentally includes the Patents' Library, is well worth getting acquainted with if you are interested in business or technology. You may also be able to get hold of more expensive books like these through the inter-library loans scheme, to which you have access through your local library.

### Conclusions

- Both volumes are well planned and executed.
- A computer professional, even in the microworld, will probably want copies of them for reference.
- However, for the average micro user, they are probably not worth buying as they are

not comprehensive enough in the information they give about micros.

Ian Litterick

## Successful software for small computers: structured programming in Basic for science, business and education

By Graham Beech, published by Sigma Technical Press. 210 pages paperback. Price £5.50 ISBN 0 905104 12 9.

THIS BOOK is intended for readers who have some knowledge of Basic and who wish to learn how to design reliable and well-structured programs which take advantage of some of the rudimentary inventions and discoveries of computer science. There are five sections — an introductory chapter which introduces structured programming and the author's program description language, PDL, and then sections on PDL and mathematics data structures, data processing and simulation.

PDL is a loosely-defined, high-level language which looks rather like Algol

interspersed with English text. Known variously as pidgin Algol or pseudocode, such languages are used widely for working-out algorithms or designing programs.

Used properly, the technique is far more effective than flowcharting both as a design tool and as a way of making the logic of a program clear to a human reader.

That is the approach followed in the book: the logic of each program is written clearly and concisely in PDL, then translated into Microsoft Basic. All programs have run successfully on a TRS-80 Model 1 Level II, 16K machine.

The introductory section describes a small set of program elements out of which structured programs can be built, and shows how they are written in PDL and translated into Basic.

Four sections each deal with a particular subject area and may be read in any order although the material in the early part of section C is needed for the examples in section B.

Section B — PDL and mathematics — describes how to write programs to solve quadratic, polynomial and simultaneous equations. Section C — data structures —

describes arrays, tables, buffers, stacks, queues, lists, trees, and graph structures; it explains why they are useful and shows how they can be implemented in Basic.

Section D — data processing — describes and compares sorting methods and explains file structures, searching, updating and merging. Section E — simulation — demonstrates techniques for both continuous and discrete simulation.

The excellent idea behind the book is, to produce a cheap, approachable introduction to some of the important ideas of good program design. Unfortunately, the book itself is seriously flawed.

To be convincing, the author needs to carry the reader easily from the PDL version of each program to its equivalent in Basic — otherwise the PDL seems irrelevant and the idea of abstract design is lost. Throughout the most important, early part of the book the readers' confidence is undermined by the large number of errors in the PDL; errors which range from syntax and proof-reading mistakes.

There are other, lesser, faults. The Basic programs are unnecessarily difficult to compare with the PDL versions because of differences in the names used for

variables. The style of the four applications sections shows their origin as course material for students at Wolverhampton Polytechnic and could be made more readily understandable by the average programmer. The material could also be made more immediately relevant if more, concrete, examples were included.

The book deserves a second edition in which these faults can be corrected because few other books contain such a wealth of algorithms and data structures at such a relatively low price.

The material, if properly understood, is worth as much as many introductory computer science courses. Despite the criticisms I would recommend the book, particularly to programmers of scientific systems or applications who have some mathematical knowledge but no computer science training.

## Conclusions

● **Excellent material, but with unfortunate faults in its presentation.**

● **Recommended, especially for first-level students and scientific programmers.**

● **A second edition, correcting the faults, could be a winner.**

## Diary

# November

● **4-6 Compec '80.** Venue: Grand Hall, Olympia, London. The leading exhibition of computers, peripherals and systems. Fee: £2. Contact: IPC Exhibitions, 40 Bowling Green Lane, London EC1R 0NE. Tel: 01-837 3636.

● **1-2, 15-16 & 29-30 Two-day intensive course in Basic programming.** Venue: London. Designed for those with little or no experience of computers, course will explain how programs may be created, documented, run and debugged using Basic. Fee: £57.50. Contact: Agar-Hutton, 194 Kilburn High Road, London NW6. Tel: 01-328 9232.

● **18, 19 & 20 Biztronic Exhibition.** Venue: Prestonfield House Hotel, Edinburgh. It features the latest in mini- and micro-computers, word-processing equipment, copiers and other electronic office equipment. Contact: Groundrule Exhibition Company, 7 Market Street, Altrincham, Cheshire WA14 1QW.

● **18-21 Video Tradex International Exhibition.** Venue: Wembley Conference Centre, North London. Demonstrates the growth and development taking place in the video industry and will provide visitors with the opportunity to see and examine in detail, the latest in video technology and techniques. Fee: Free for people in Industry. Contact: Ken Warton or Janet Tring, Link House, Dingwall Avenue, Croydon CR9 2TA. Surrey. Tel: 01-686 2599.

● **24 System design with microprocessors.** Venue: Merton Technical College, Surrey. Two-week full-time course including both the hardware and software aspects of microprocessors, designed specifically for practising engineers. More than half the time is devoted to practical work where course members can gain hands-on experience of disc-based microprocessor development systems. Fee: £50. Contact: Bill Wittams or Terry Baylis, School of Engineering, Merton Technical College, Morden Park, London Road, Morden, Surrey SM4 5LZ. Tel: 01-640 3001 extn. 56.

● **25 Practical introduction to microprocessors.** Venue: Cambridge. Covers the basics of microprocessors and how to use them with hands-on training using the SGS-ATES Nanocomputer. Fee: £55 + VAT. If you buy a Nanocomputer, the course is free. Contact: Cambridge Microcomputers Ltd, Cambridge Science Park, Milton Road, Cambridge CB4 4BN. Tel: 0223 314666.

● **25-28 The Which Computer Show.** Venue: National Exhibition Centre, Birmingham. Contact: Gail Sheridan, Sheridan Communications Ltd, Clifton House, 77 Francis Road, Edgbaston, Birmingham B16 8SP. Tel: 021-454 4214.

● **26-30 Breadboard '80 Exhibition.** Venue: Royal Horticultural Halls, London SW1. Show for electronics enthusiasts. Fee: £1.50, students and O.A.P.s £1. Contact: Louisa Redfern, Trident International Exhibitions Ltd, 21 Plymouth Road, Tavistock, Devon PL19 8AU. Tel: 0822 4671.



Telephone Answering Machines  
 Phone Mate ... Own Your Own  
 910 fixed time rec. .... £115  
 920 voice actuated. .... £170  
 925 remote control. .... £185  
 930 rem + voice act. .... £250  
 Prices inclusive UK dly. + ins.  
 Cheques please to Europhonic  
 Moonrakers, Wheatsheaf Enc.  
 Liphook, Hants. GU30 7EJ.  
 Liphook (0428) 722563 anytime

• Circle No. 187

**WHEEEE—BANK—POP**  
 NEW SOUND BOARD FOR MOST  
 COMPUTERS.

**SOUND BOARD £40 BUILT £35 KIT**  
 TUNES—CHORDS & EFFECTS—FULLY  
 PROGRAMMABLE  
 CONNECTS TO 10 BITS OF ANY I/O PORT  
 LOUDSPEAKER, AMP & BATTERY  
 INCLUDED.  
 CASED + £3  
 (USES AY-3-8910)

**JOYSTICKS £15 PER PAIR (BUILT)**  
 CASED & COMPLETE WITH 2 PUSH  
 SWITCHES & 1 METRE OF CABLE PER UNIT  
 PAIR OF 2 AXIS JOYSTICKS CONNECTS  
 DIRECT TO MOST 8 BIT I/O PORTS.

**COMPUKIT/SUPERBOARD**  
**OWNERS: I/O PORT £40 BUILT £35 KIT**  
 24 LINE I/O PORT COMPLETE WITH 28T28  
 BUFFER CHIPS AND ON BOARD RELAY.  
 PLUGS STRAIGHT IN TO 40 PIN EXPANSION  
 SKT.

**LIGHT PEN £15 INC SOFTWARE**  
 USES OUR I/O PORT. HARDWARE,  
 SOFTWARE & MANUAL SUPPLIED.  
 (K101 ONLY)

**NASCOM OWNERS MIC CODE PGMS**  
 KINESIS-SOUND BOARD OPERATING  
 SYSTEM. COMPOSE TUNES & PROVIDE  
 GRAPHICS. NEEDS 16K £15

**BRICKS & TENNIS • 2 JOYSTICK GAMES •**  
 USES OUR JOYSTICKS. £3.50  
**SPACE INVADERS & CATCH THE CRITTERS**  
 £3.50

**STATE MONITOR WHEN ORDERING.**  
 ALL SOFTWARE ON TOP QUALITY  
 CASSETTE.

**ALL PRICES INCLUDE VAT, P+P**  
**ALL EX STOCK**

**HYSPEC**  
 P.O. BOX 39,  
 LITTLEHAMPTON,  
 WEST SUSSEX BN17 6NZ

• Circle No. 188

**BUILDING  
 RAMS?**

Why waste time hand-wiring RAMS? This  
 5.3x2.5 inch professional plated thru PCB  
 mounts on your prototyping board, looking  
 like an 8K byte TTL compatible static RAM.  
 13 address lines, 8 data I/O, write enable,  
 2 neg and 1 positive card selects.  
 Assembled with sockets, pins and caps, just  
 plug in 16 2114's and 1 74LS138 £21. Bare  
 board £15, no VAT, post paid.

**P. G. Hinch**  
 56H Norris Hill Drive,  
 Heaton Norris,  
 Stockport  
 Cheshire

• Circle No. 189

# Parameters and I/O techniques

LAST MONTH, we looked at subroutines, and how, where and why they might be used; we complete our survey this month. In particular, we look at how parameters are passed between the calling program and its subroutine(s).

In the second part of this month's article, I describe the input/output, I/O, methods which micros normally use. After all, the cleverest system is no use unless it can talk to the outside world.

It is a rare subroutine that does not take data from, or pass data to, the program that called it. Often, data goes both ways. Part of the secret of designing an effective subroutine is to calculate precisely how data is to be passed.

It is almost a certainty that, if you are using a library of subroutines which transfer data via memory, you will eventually have one routine corrupting another's workspace. One way round the problem is to have a block of memory allocated to subroutine data, and to make sure that every routine uses a different address in that area. This still is not a good approach, and you should avoid it if you can.

The alternative is to transfer data in either the internal registers, or in the stack. Using internal registers is very fast, but has an obvious disadvantage — there

is little space. The alternative of using the stack may give more space, but it introduces problems in handling the SP. Sometimes, it is possible to use two stacks — one for parameters and one for return addresses — to obviate the problem. The 6502, once again, restricts us, because its stacks must be on page one.

Often, the best solution is to use either the stack, or internal registers, to pass pointers to the data. The calling program can then put the data wherever is most convenient. That is the only practical approach to subroutines which must handle lists of data. If you look back at

by David Peckett

some of the program segments that I gave in earlier parts of this series, you will see I often used the pointer technique to access data. You only need to add a "Return" to make them into subroutines.

**Workspace.** We have only been looking at the problems of entering data into and taking data from subroutines. Often, though, they often need some kind of scratchpad in their working. The same kind of constraints apply to this also — it must not overwrite any important data.

Sometimes, you can use the stack as a scratchpad area. Occasionally, though, you must use main memory and, again, you should set aside a block just for this purpose. Often, it can be very small, because several routines can use the same addresses without interfering with each other.

**Recursion.** Recursion is a programming technique in which a subroutine can call itself. The technique is not very common in micros. The important point is that a recursive subroutine may be nested into itself many times, without corrupting any data. About the only option is to pass data via the stack; addresses in memory are totally useless.

**Re-entrancy.** I shall soon be describing interrupt techniques. Without leaping ahead too far, an interrupt is an external event, e.g., a key's being pressed, which can happen at any time, and which must be serviced immediately. Subroutines are said to be re-entrant if they can be interrupted to allow other program segments to run, and then re-started, with no fear of data corruption.

To make a subroutine re-entrant, it must normally be written to use only internal registers — which are saved on the stack during an interrupt — and the stack. It is a good practice to try to make

Figure 1. Sort subroutine.

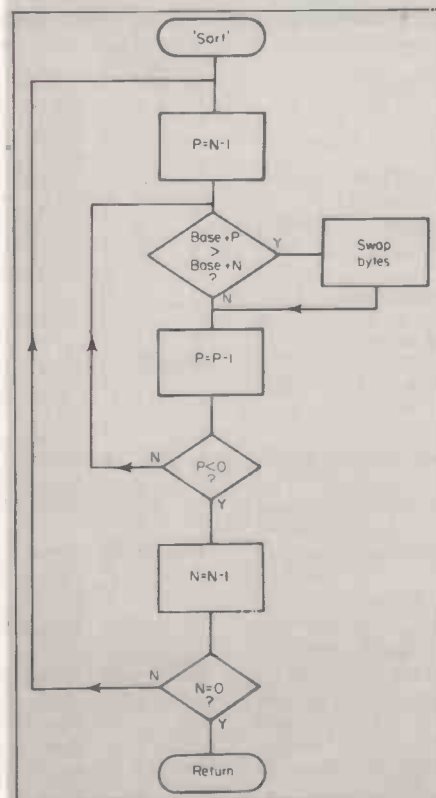





```

;SORTING SUBROUTINE FOR 6502
;SORTS A MAXIMUM OF 256 BYTES INTO
;ASCENDING ORDER
;PARAMETER TRANSFER:
; A: LSB OF BASE ADDRESS OF DATA BLOCK
; X: LSB OF BASE ADDRESS OF DATA BLOCK
; Y: NUMBER OF BYTES
SORT   PHP           ;SAVE FLAGS
      STX BASE      ;SET UP BASE
      STA BASE+1    ;..ADDRESS
      D-Y          ;SET INDEX CORRECTLY
LOOP1  TYA          ;SET
      TAX          ;..X=N
      DEK          ;FOR: P IN X
      LDA (BASE),Y ;GET TOP BYTE
      JSR SWAPXY   ;Y=N, X=P
      CMP (BASE),Y ;COMPARE BYTES
; IF CY=1, SECOND BYTE IS NOT LARGER
      BCS NOSWAP
;SWAP THE TWO BYTES
      PHA          ;SAVE FIRST IN STACK
      LDA (BASE),Y ;A=SECOND BYTE
      JSR SWAPXY   ;Y=N, X=P
      STA (BASE),Y ;Y=N, X=P
      JSR SWAPXY   ;Y=P, X=N
      PLA          ;RECOVER FIRST BYTE
      STA (BASE),Y ;COMPLETE SWAP
NOSWAP JSR SWAPXY   ;Y=N, X=P
      TAX          ;SET Z FLAG FOR X
      BEQ NEXT     ;FINAL PASS, IF X=0
      DEK          ;..NEXT
      JMP LOOP2    ;..ITERATION
NEXT   DEY
      BNE LOOP1    ;FINISHED?
      PLP          ;YES, RESTORE PSW
      RTS         ;RETURN FROM SORT
;THE NEXT SUBROUTINE EXCHANGES X AND Y
;SWAPXY PHA          ;SAVE A IN STACK
      TYA          ;Y TO STACK
      PHA
      TAY          ;X TO Y
      PLA
      TAX          ;Y TO X
      PLA          ;RESTORE A
      RTS
    
```

Figure 2.

all library subroutines re-entrant, so that they can be used with any calling program, whether or not it uses interrupts.

**Solutions.** As in most things, there is no complete solution to the problem of passing data to and from subroutines. You must select the best answer to your particular problem. In general terms, though, you should aim to use internal registers as your first choice, the stack as a second option, and only use main memory as a last resort.

**Documentation.** I have stressed the value of a subroutine library. If you take this approach, good documentation becomes doubly important. Unless you know exactly what a subroutine does, it is very hard to use it. In addition to the flowchart and listing, you must record such things as:

- How data is transferred to and from the routine.
- Which variables, if any, use main memory.
- Limitations on the routine's capability, e.g., it cannot handle lists of more than 256 elements.

A handy way to record that data is in the form of comments in the listing of the routine.

**Transparent subroutines.** Having established that a subroutine data will normally be transferred via the micro's registers, we must be careful about any registers which are not used for data transfer. It is quite likely that the routine will use all the micro's registers; the calling program must, therefore, ensure that there is nothing left which must not be corrupted.

A neater alternative to relying on the calling program is to write transparent subroutines. At the end of such a routine, any data in registers not used for transferring parameters is the same as at the start — the subroutine is transparent to these registers.

Let us now try to write a subroutine which could go into a program library. A good example would be a sort, and we shall aim to make it both re-entrant and transparent.

There are many kinds of sorts, with different varieties for different occasions. We shall take the simplest, and use the flowchart of figure 1. The routine aims to take a list of "n" items, and re-arrange them so that they fill the same block of memory in ascending order. The largest byte will be at the highest address.

The sort starts at the highest address, i.e., the "n"th byte, and compares the byte at that location to every other. Whenever the top byte is smaller than the one to which it is compared, the two are swapped.

After the first pass, therefore, the largest byte in the block is at the highest address. The comparison and swap is then repeated for the (n-1)th byte and so on. Eventually, the two lowest bytes are compared, swapped if necessary, and the sort is over.

That type of sort is most effective when the data is jumbled at random, and there are only a relatively few items to be sorted. We shall limit the subroutine to a maximum of 255 items, and make each item a single, unsigned, byte.

What data must be passed into the subroutine? Only two items are needed:

- The address of the bottom of the block of data.
- The number of bytes in the block.

At the end, the subroutine will leave the sorted block in its original location.

(continued on next page)

Figure 3.

```

;SORTING SUBROUTINE FOR Z80
;SORTS A MAXIMUM OF 256 BYTES INTO
;ASCENDING ORDER
;PARAMETER TRANSFER:
; C: NUMBER OF BYTES
; HL: BASE ADDRESS OF DATA
;ROUTINE IS TRANSPARENT AND RE-ENTRANT
;
SORT   PUSH AF       ;SAVE REGISTERS
      PUSH BC       ;..TO MAKE ROUTINE
      PUSH DE       ;..TRANSPARENT
      LD B,0
      DEC C         ;OUTER LOOP COUNTER
      ADD HL,BC     ;POINT TO TOP ELEMENT
      EX DE,HL     ;TOP POINTER TO DE
LOOP1  LD B,C       ;INNER LOOP COUNTER
      LD H,D       ;HL IS POINTER
      LD L,E       ;..FOR
      DEC HL       ;..INNER LOOP
      LD A,(DE)    ;TOP ELEMENT TO A
      CP (HL)      ;IS SECOND WORD
      JP E,NOSWAP  ;..LARGER?
;LOWER WORD IS LARGER - SWAP WORDS
      PUSH AF      ;SAVE A IN STACK
      LD A,(HL)   ;MOVE SECOND
      LD (DE),A   ;..WORD
      POP AF      ;RECOVER FIRST WORD
      LD (HL),A   ;COMPLETE SWAP
NOSWAP DEC HL     ;POINT TO NEXT WORD
;MOVE TO NEXT "TOP" WORD
      DJNZ LOOP2  ;INNER LOOP OVER?
      DEC DE
      DEC C
      JNZ LOOP1   ;FINISHED?
;SORT OVER, RESTORE REGISTERS FROM STACK
      POP DE
      POP BC
      POP AF
      RET
    
```

## UNIVERSITY OF EXETER ELECTRONICS TECHNICIAN

Applications are invited for the post of Electronics Technician in the Microprocessor Unit. This unit has recently been set up within the Computer Unit to give advice and support to users of microprocessors throughout the University. The successful applicant will be responsible for the running of a small microprocessor workshop, the development and construction of microprocessor based electronic systems including interfacing of such systems to the Computer Unit's communications network and the preparation of associated diagrams and documentation. Applicants should have experience in digital electronics.

Salary will be in the range £4776-£5577 p.a. (Grade 5 Technician)

Further particulars may be obtained from Mrs Doreen Birch, Northcote House, Queen's Drive, Exeter, EX44QJ.

Applications in writing, stating age, educational qualifications, relevant experience and the names of two referees should also be sent to this address by 31 October 1980. Please quote reference No. 5155.

• Circle No. 190

## Software for TRS80®

### Best Sellers from Southern:

#### ACCEL Compiler for Level 2 BASIC £19.95

Accepts correct, properly-structured Level 2 BASIC programs. Gives 10-30 times improvement in performance of GOTO, GOSUB, RETURN, Integer operations, IF, THEN, ELSE, ON, SET, RESET, PEEK, POKE, POINT, FOR, NEXT.

#### ACCEL2 Compiler for Disk BASIC £39.95

All the power of ACCEL on full Disk BASIC, plus performance improvements on non-integer operations and 1-dim arrays. String-handling 3 or 4 times faster.

#### TSAVE Prepare System Tapes £4.95

Takes core image backups of machine-code programs.

#### FGRAF Fast Graphics £4.95

Machine-code subroutines. For drawing lines, moving balls and boxes. Callable from BASIC.

SOUTHERN SOFTWARE, P.O. Box 39  
Eastleigh, Hants. SO5 5WQ

• Circle No. 191

## SUPERBRAIN SOFTWARE

Microsoft	
*BASIC Interpreter	£175
*BASIC-80 Compiler	£210
*FORTRAN-80 Compiler	£270
*COBOL-80 Compiler	£390

Micropro	
*WOROSTAR	£250
*MAIL/MERGE	£75
*OATASTAR	£195

Most items in stock  
2% discount for cash with order  
Dealer terms Available

Contact:  
THE MICRO SOLUTION LTD  
Park Farm House, Heythrop  
Chipping Norton, Oxon OX7 5TW  
Tel: (0608-3256)

• Circle No. 192

# SHOP WINDOW

## TOP MARK Computers

dedicated to  
**APPLE II**

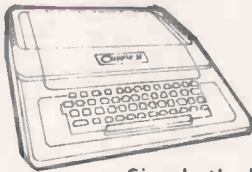

Simply the best!

Full details from Tom Piercy on  
Huntingdon (0480) 212563 or circle  
enquiry card.

• Circle No. 193

Verbatim



### TOP QUALITY FLOPPIES

Single Side Single Density Diskettes	All Inclusive Unit Price	Price per Box
8"	£2.42	£29.55
5 1/4"	£1.83	£22.77

Sold in Boxes of 10

Always Quote Your Machine Type When Ordering

- Many other Types Available
- We Can Quote for Your Machine
- Quantity Discount For 50+
- Please Give Us A Ring

**GRAM**  
BUSINESS SYSTEMS

48 HEDLEY STREET,  
MAIDSTONE, KENT ME14 5AD  
MAIL ORDER ONLY

• Circle No. 194

### LB ELECTRONICS

11 HERCIES ROAD, HILLINGDON, MIDDX.  
T.M.S. 2516 (single rail) Full spec. £895.00  
2708 (450ns) £4.50.  
2526 Character generator with data £2.95.  
SN 74116 60p, SN74118 70p, SN74194 50p,  
SN74198 75p, 74LS 240 £1.50, 74LS 245 £2.40,  
74LS 266 75p, 74S260 40p, 710 (dii) 25p, 711 (dii) 30p,  
2102 (650 NS) 48p, FND 500, 0.5 inch LED Display  
(cc) ful spec. 50p, 12 for £5.00.  
HEADER PLUGS 16 way with cover 60p, 16 way  
without cover 35p, 24 way without cover 95p  
DIL switches, 4 way 75p, 7 way £1.00, 8 way £1.20,  
10 way £1.40.  
JUST ARRIVED ITT 2082.  
1200 Baud data modern cc I tv 24/rs 232c  
Channel Centre frequencies 1300 and 1700 hz  
(600 baud) or 1300 and 21hz (12 baud).  
Synchronous or asynchronous operation over  
2 or 4 wire switched or dedicated lines. Built in  
test and Line test functions.  
Brand new with manual £115 p/p £3.00.  
All prices inclusive of VAT P/P on all components 30p.  
Tel: UXBRIDGE 55399.  
Access or Barclaycard Accepted.

• Circle No. 195

(continued from previous page)

**6502 sort.** The 6502 sorting routine is shown in figure 2. The number of bytes is passed in Y; X contains the low byte of the data's base address and A contains the high address.

Since the routine is to be transparent, its first act is to save the PSW on the stack; all the other registers contain data. Because of the 6502 addressing limitations, and its lack of registers, it is not practical to make the routine absolutely re-entrant. The base address must be stored in memory at some suitably-protected spot — "BASE". If you had wanted, the calling routine could have loaded "BASE" directly, with little effect on the usefulness of the routine.

During the sort, we shall have to use indirect-indexed addressing to access the

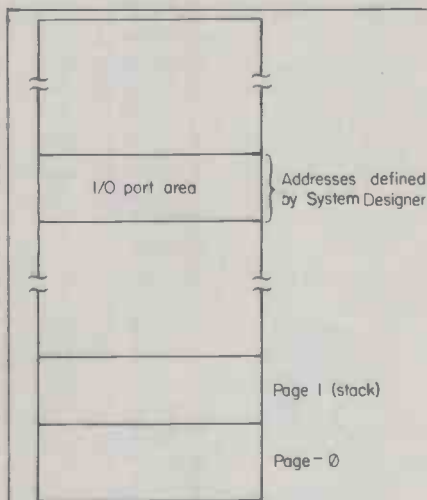

Figure 4.

data. "BASE" must, therefore, be on page 0. Y will be used as a counter for the outer loop — "N" in figure 1 — and X as the inner loop counter — "P". We have to go through the outer loop (N-1) times, and so we decrement Y once to make the initial count correct. This also sets us up to point to the highest address of the block of data — "BASE" + N - 1.

At the start of each outer loop, Y is transferred to X, which is decremented to set up P. We then go into the inner loop,

Figure 5. Complete microcomputer.

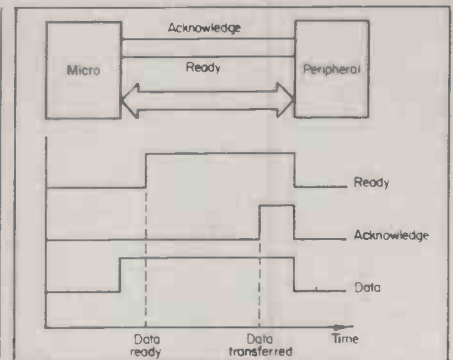
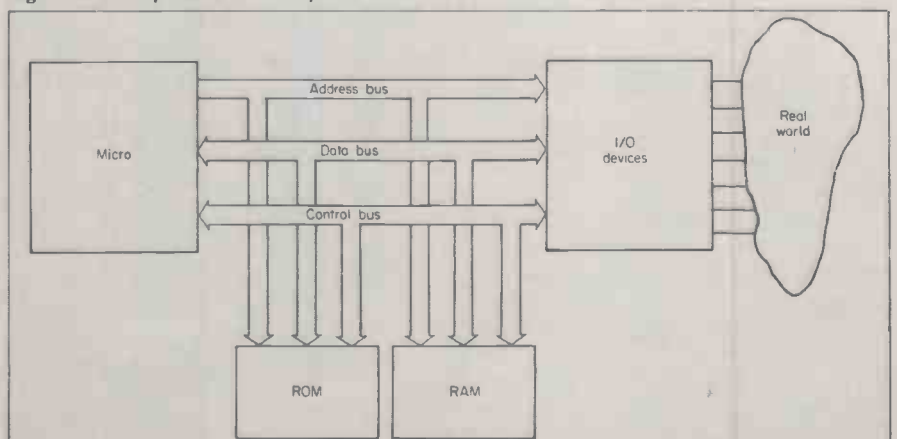

Figure 6. Input handshake.

and the fun starts. We can use only indirect-indexed addressing with Y, but need to use the data in both X and Y. We, therefore, must swap X and Y several times. The best way is to use a special subroutine, SWAPXY, for the purpose.

**SWAPXY.** This routine is itself re-entrant, and transfers X and Y via A and the stack. During the transfer, the original data in A is saved in the stack, and is restored at the end.

Comparing the two items of data is straightforward. If we have to swap them, there is more juggling of X and Y so that we can get at the proper addresses. The data is, again, exchanged via the stack. There are two possible paths through the inner loop. I had to be careful to give an even number of calls to "SWAPXY" on each so that, at the end of each iteration, X and Y contain "P" and "N" respectively.

The outer loop iterates until N is decremented to zero, when the sort is over. On each pass through the outer loop, the last iteration of the inner loop occurs with P = 0, i.e., the lowest address in the block of data. The conditional branch therefore tests X before it is decremented — why can we not test for X negative?

The final act of the subroutine is to restore the PSW, which was in the stack all the time. Note that we never worried about the value of the SP; as long as we keep pushes and pops symmetrical, the data on the stack stays in the right order. Z-80 sort. The Z-80 sort is much more straightforward than that of the 6502. The base address is passed in HL, and the

number of bytes in C. The first act, therefore, is to save AF, BC (for B) and DE on the stack.

A 16-bit addition is used to set HL to the address of the highest byte, and this is passed to DE for the rest of the routine. That is because when we arrive at the comparison step, we must use HL to imply the address of the byte to be compared to A.

The start of the outer loop loads B to act as the inner loop counter (P), and HL is set to the address of the first byte to be compared. Because we are using separate registers for counting and pointing, the use of the loop counters is, maybe, a little obscure. We go through the outer loop (N-1) times — the counter is C, which is set to (N-1) early on. Each time we go

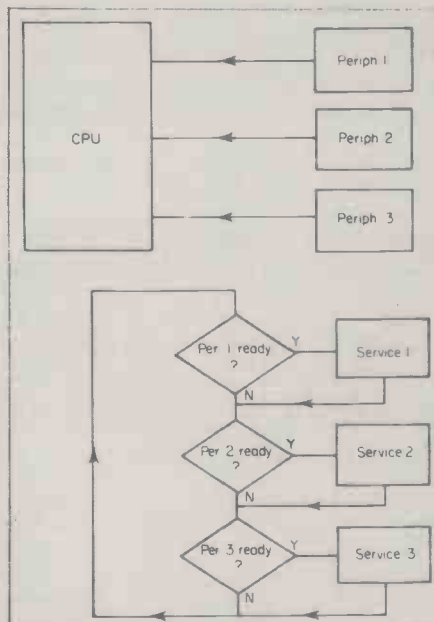

Figure 7. Polling of interrupts.

through the outer loop, the inner loop is iterated the same number of times as is left in C. The inner loop counter, B, is easy to set.

Swapping the bytes is straightforward and, like the 6502 program, uses the stack for temporary storage. Finally, at the end of the routine, the registers which we put in the stack are restored to preserve the routine's transparency.

It often happens that a subroutine must be called conditionally, for instance, a byte must be manipulated if it is less than 80<sub>16</sub>. From what we have seen so far, we would have to combine a conditional jump and a call to obtain this effect:

```
CP 80 ;LESS
JP P,NOCALL ;THAN 80?
CALL ALTER ;YES —
;MODIFY
```

```
NOCALL NOP ;CONTINUE
```

The Z-80, however, has a full set of conditional calls — table 1. They use exactly the same conditions as the micro's conditional jumps, and make that kind of problem much simpler:

```
CP 80 ;LESS
CALL M,ALTER ;THAN 80?
;YES —
;MODIFY
```

```
;CONTINUE
```

Obviously, the condition for the call must be the complement of the condition for a jump which will miss the call. In the same vein, a subroutine may make a conditional return. That can be particularly true if the routine can exit at several points, depending, e.g., on whether A is zero:

```
CP 0 ;A=0?
JP NZ,NOTZRO ;YES —
RET ;RETURN
```

```
NOTZRO NOP ;CONTINUE
```

The Z-80 has a full set of conditional returns, matching its conditional calls and jumps. They would allow us to write the program segment above as:

```
CP 0 ;A=0?
RET Z ;YES — RETURN
```

```
;CONTINUE
```

The careful use of these conditional calls and returns can make a Z-80 program noticeably more efficient. The 6502 has no comparable instructions.

The Z-80 has one more stack-orientated instruction — "EXchange HL with the two bytes on the top of the stack" ("EX(SP),HL"). That is an unusual instruction. About its only practical use is for modifying a return address. Occasionally, the address will depend on what happens in the routine. It is not very good programming practice, but this instruction gives a quick way of modifying the return address.

All the way through this series, we have assumed that data was available whenever we needed it, and could be output as and when necessary. We have not given

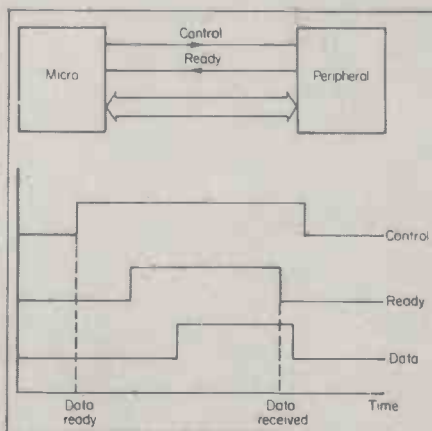

Figure 8. Output handshake.

any thought to how it leaves and enters the microcomputer.

First of all, what kind of communication is needed? Obvious examples are reading a keyboard, writing to a printer, and handling tape and disc units. In many applications, micros must control external equipment, sending it command signals via digital-to-analogue (D/A) converters, and receiving data from A/D converters.

(continued on next page)



## The Complete Service Analysis to Implementation

Business, Scientific and Engineering  
Applications

We specialise in Management  
Information and  
Administrative Control Systems

Suppliers of VECTOR GRAPHIC  
Computer Systems  
From single user to distributed  
processing —

Business and Word Processing  
Packages

Phoenix Computing Services  
75 Hemingford Road, Cambridge  
CB1 3BY  
(0223) 212392/211207

• Circle No. 196

# 2 heads are better than 1

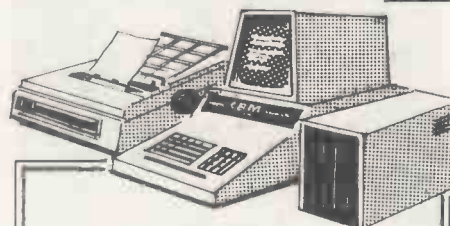

Impetus offers a personalised programming service in accounting and file management. Headed by an experienced accountant plus an expert mainframe programmer, they together bring an expertise to your problems.

The Company specialises in incomplete records for accountants — a complete package with flexible input procedures which can be modified by the operator; stock control, open-item purchase and sales and nominal ledger systems.

Impetus can also provide a complete payroll package which has been especially designed for first time users to simplify tax, national insurance and many other calculations such as pension schemes. Word processing is another area where the expertise behind Impetus is put to good use.

The Impetus programming service is ready to be of use to you.

Telephone or write:  
IMPETUS Computer Systems

# impetus Computer Systems

Classic Offices,  
Hendon Central, London NW43NN  
Tel: 01-202 2726  
01-202 9630 (24hr. service)

• Circle No. 197



## Target Electronics

16 Cherry Lane, Bristol BS1 3NG  
Telephone: 0272 421196

### NASCOM IMP PLAIN PAPER PRINTER



The Nascom IMP (Impact Matrix Printer) features:  
 ● 50 lines per minute ● 80 characters per line ● Bi-directional printing ● 10 line print buffer ● Automatic CR/LF ● 96 characters ASCII set (includes upper/lower case, \$, #, @)  
 ● Accepts 8 1/2" paper (pressure feed) ● Accepts 9 1/2" paper (tractor feed) ● Tractor/pressure feed ● Baud rate from 110 to 9600 ● External signal for optional synchronisation of baud rate  
 ● Serial RS232 interface



### NASCOM DISTRIBUTOR

● Please add 15% VAT ●

Large selection of aluminium boxes & Instrument Cases  
Phone in your Access or Barclaycard order Catalogue 25p post paid

● Circle No. 198

## WHO SAID CREATIVITY IS DEAD?

We can help you with the application of micros to chemical engineering problems:

- PROCESS DESIGN
- ENGINEERING CALCS.
- MIMIC & PROCESS FLOW DIAGRAMS
- PROCESS SIMULATION
- CONTROL

COLIN GRACE & PARTNERS  
FAIRFIELDS HOUSE  
ASHDON  
SAFFRON WALDEN, ESSEX  
CB10 2NA  
TEL: (079984) 355

● Circle No. 199



Digital Microsystems

### OVERPRICED COMPUTERS INADEQUATE PERSONAL MICROS?

Modata supply Dealers and OEMs with Digital Microsystems competitively priced Single and Multi-User computers which include Reliable Floppy and Hard Disk storage.

ie. DSC-2: Z80 at 4MHz + 64Kb +  
2 x SSDD 8" Floppies for 1Mb + CP/M  
= £3525 E.U.

WHY NOT FIND OUT MORE?  
0892 41555

Modata Ltd. 30 St. Johns Road,  
Tunbridge Wells, Kent TN4 9NT

● Circle No. 200

(continued from previous page)

Data invariably enters and leaves the micro in bytes. However, there may well be isolated control lines to set and status lines to read. Furthermore, data may enter and leave the system in a serial stream. Essentially, there are three I/O techniques which can be used with a computer:

**Memory-mapping.** Memory-mapped I/O treats ports — the points where data actually enters or leaves the system — as addresses in main memory. Data is written

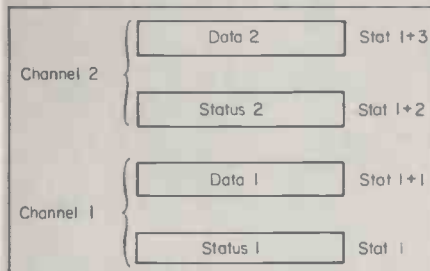
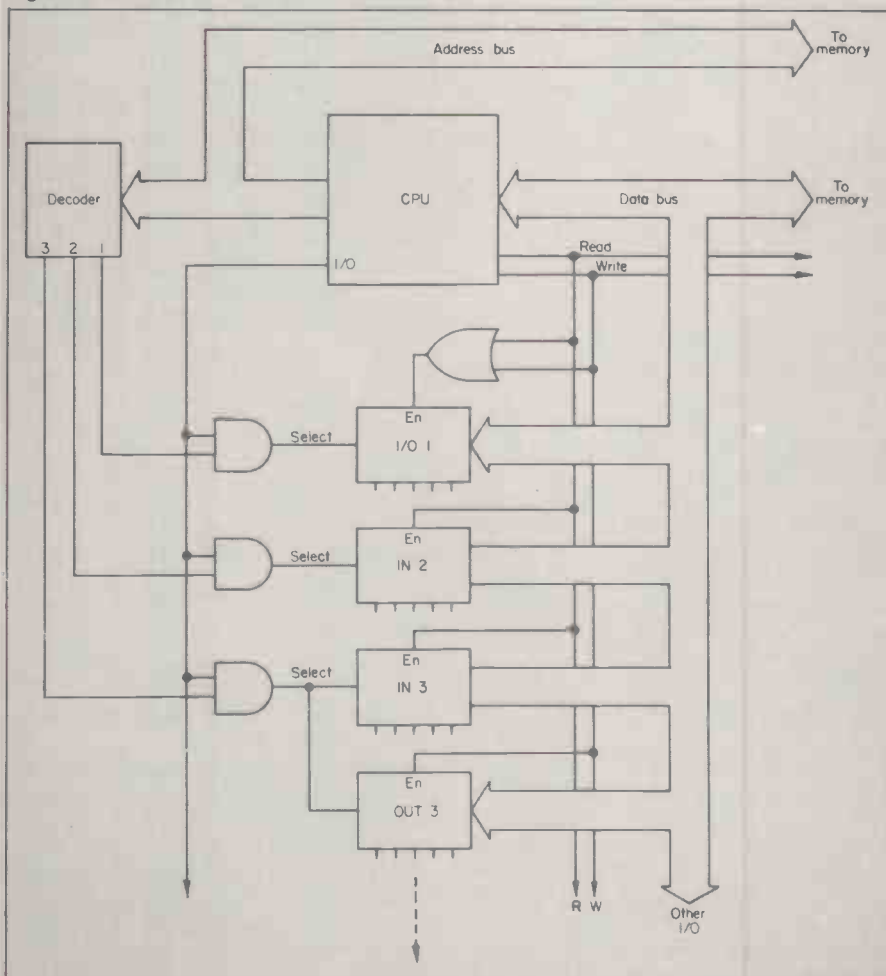

Figure 10. I/O port configuration.

and read normally, and can be manipulated in the usual ways. Special interface chips, wired to the micro's address, data, and control busses, do the job of moving the data. Those chips also convert between the micro's byte-orientated data and whatever form is used in the outside world. All micros can use this technique.

Figure 9. Control of Z-80 I/O.



**Special I/O instructions.** Some micros, such as the Z-80, have special instructions for writing to, and reading from their I/O ports. Although the interface chips which provide the ports are linked to the micro's busses, they are not part of the system's memory.

**Direct memory access (DMA).** DMA is a special method of which an external device, e.g., a disc, stops the micro, takes control of its busses, and writes to or reads from memory directly.

Memory-mapping is a very simple procedure, but can obviously interface with the size of the micro's memory, particularly if there are many I/O ports. The special instructions of the Z-80 allow a more flexible approach at the penalty of a more complex instruction set and extra hardware.

Whichever approach is to be used, the manufacturer of the micro will invariably offer a family of programmable peripheral chips which can be assembled to form a complete microcomputer — figure 5.

**Controlling I/O.** When a micro takes in data from external devices, it has to know when that data is ready. One way is to use interrupts. In its simplest form, an interrupt is an electrical signal which an external device applies to a micro. The signal makes the micro stop what it is doing, and run a special segment of



The chips are all very complex LSI devices, and allow the micro to talk to the outside world. Different devices act as memory-mapped I/O — parallel and serial — timers, discrete ports, floppy-disc controllers, etc. Sometimes, functions such as ROM, RAM and I/O are combined.

Every micro has its own family of chips, and does not normally use other types. The Z-80, however, can use any of the Intel devices designed for the 8080A and 8085. It also has a few of its own special chips, such as the Z-80 parallel input/output — PI/O — and the serial I/O — SI/O.

The 6502 is related to the Motorola 6800, and some of the two micros' I/O chips are very similar. For instance, the 6502 PIO is virtually the same as the Motorola 6820 peripheral interface adaptor — PIA. Peripheral chips are normally programmable, in order to select their different operating modes.

What are the special I/O instructions which the Z-80 provides? The Z-80, like the 8080A, can service up to 256 input, and up to 256 output, ports. It can, therefore, handle up to 512 interfaces, each one eight bits wide. In fact, there are ways of

*(continued on next page)*

Figure 11b. Subroutine store.

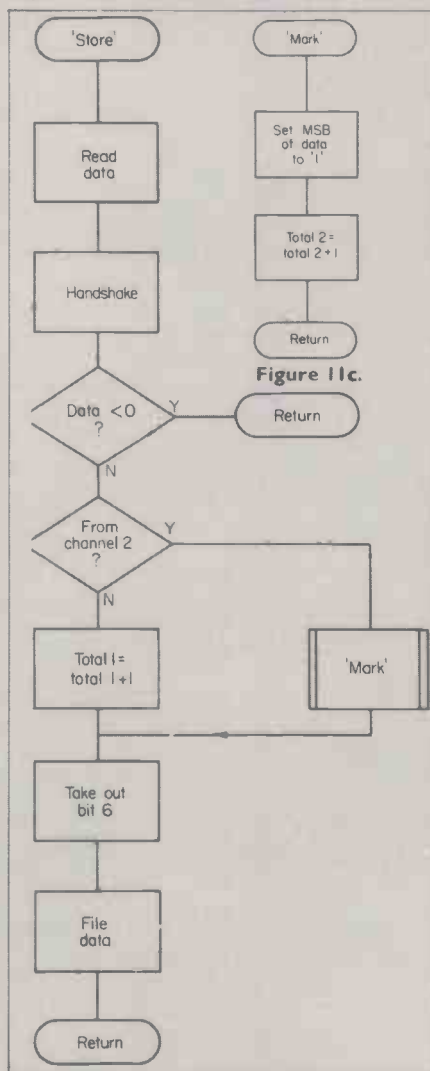

Figure 11c.

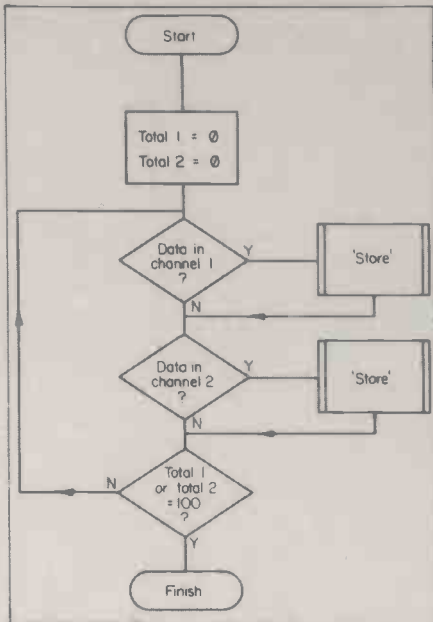

Figure 11a. Basic program loop.

program to service the peripheral. Having done that, the original program picks up exactly where it was so rudely interrupted. In an interrupt-driven system, peripherals grab the CPU attention as and when they need it.

The other common way of discovering when any peripheral is ready is to poll them all. It is quite easy to design a system so that, when a peripheral has data ready for the CPU, it sets a ready line. The micro can check all the ready lines at regular intervals to see if it needs to do anything. In earlier articles, I have given examples of program segments which check ready lines. The line usually sets the MSB of a status word — the micro can best this bit very easily.

Having read the data, the CPU can respond by setting an acknowledge line to the peripheral to say that it is finished, and is ready for more — figure 6. That type of response is called a handshake, and is essential if the external device can provide data fast enough to swamp the micro. It gives the CPU more control of the peripheral.

The problem with a polling technique is that the micro can spend a good deal of time in a loop waiting for something to happen — figure 7. Often, that does not matter — it may have to wait for the operator anyway. At other times, though, it could be doing something useful while it is waiting — like setting-up the universe for the next game of Star Trek. Polling is often used because it is simple.

Handshaking is almost essential when the micro is outputting data — figure 8. The CPU must first set a line to ask the peripheral whether it is ready to listen to it. Some indeterminate time later, the device will say yes by setting a ready line. That allows the data transfer to occur — when the peripheral has received the data, it will lower the ready line.

A micro is the central member of a family of chips from its manufacturer.

## BRISTOL & WEST APPLE SHARP MZ 80K H-P 85A

dbm Systems & Software  
58 Victoria St., Bristol 1  
Telephone 0272 214093

• Circle No. 201

UNDER  
£30  
+  
VAT



MICROCASE "turns a board into a real computer"

## STRONG — STYLISH — GUARANTEED NASCOM 1&2 COMPUKIT SUPERBOARD

& UN CUT FOR OEM USE

from your dealer or from  
SIMPLE SOFTWARE LTD  
15 HAVELOCK ROAD  
BRIGHTON SUSSEX



PET?

PROGRAMMERS  
TOOLKIT 16/32K  
ONLY. LIMITED  
NUMBER AT:

£40  
+  
VAT

• Circle No. 202

## DISKWISE



THE Apple Agents  
in Devon & Cornwall  
Present  
Quality Software direct or from your  
local Apple Dealer.

HOTELPLAN — Hotel Management  
system inc. booking & Guest Billing.  
£475. TV RENTAL MANAGEMENT  
£395.

TRADE ENQUIRIES WELCOME  
25 Fore St., Callington, Cornwall  
Tel. 05793 3780

apple computer  
Sales and Service

• Circle No. 203



**SYNTAX SOFTWARE**

announce their range of software for the

**SINCLAIR ZX80**

**ZX80 SUPAPACK ALPHA £4.95**

(Kamikaze Alien, Duckshoot, Digital Clock, Docker and Safebreak)

**ZX80 SUPAPACK BETA £4.95**

(Cave Master, Star-Blinder, Juggler, Bishops Berkley and Whirlpool)

Please make cheques/P.O.'s payable to:—

**SYNTAX SOFTWARE**

96, COLLINWOOD GARDENS

GANTS HILL,

ILFORD,

ESSEX.

All prices include

V.A.T. & P&P

PLEASE ALLOW 14 DAYS FOR DELIVERY

• Circle No. 204

**APPLE II/ITT 2020 RELOCATED INTEGER**

Enables any Integer programme to run on an Apple II Plus/ITT Palsoft machine without an Integer card. Specify memory size when ordering.

Cassette Systems £12 Disc Systems £14

**SPEED CONTROL/PAGE LIST**

Adjustable text output speed using the game control paddle. Use to list/edit Integer, Floating Point, and Monitor programmes and also incorporate in your own programmes.

Supplied on Cassette £8, or Disk £8

**AUTO-INDEX**

Master-catalogue programme featuring fully automatic updating facility and Comprehensive Edit & Interrogation routines. Requires 48K and one disk drive £18.00.

D. J. BOLTON, 1 BRANCH RD, PARK STREET, ST. ALBANS. TEL: PARK STREET (0727) 72917.

• Circle No. 205

**BROKEN COMPUTERS MENDED**

Fast reliable service by professional computer engineers. All models catered for.

For further details please contact:

**BYRD ASSOCIATES** on Bedford (0234) 214785 (24 hour answering service) or write to us at 43 Ashburnham Road, Bedford.

• Circle No. 206

**DO YOU LIVE IN CORNWALL**

**J.M. COMPUTER SERVICES LIMITED**  
76 FORE STREET  
NEWQUAY

are please to announce the opening of their second branch at

**15 LEMON STREET TRURO**  
FURTHER DETAILS  
TELEPHONE (06373) 2863

• Circle No. 207

(continued from previous page)

obtaining up to 64K each of input and output ports.

Table 1 shows the I/O instructions and, as you can see, there are two of each kind. "IN A, (N)" and "OUT (N),A" are equivalent to 8080A commands, and load the accumulator with, or write its contents to, port N. N can be any number from 0 to 255.

The Z-80 also has register-implied I/O instructions: "IN r,(C)" and "OUT (C),r". The data in register C gives the port address, and the contents of any register — including C — can be moved. **Mechanisation of in and out.** What extra hardware do special I/O instructions need? Figure 9 shows the kind of circuits used with Z-80 I/O peripherals; the signals represent only what is happening — they are not necessarily precise.

During an in or out, the port address goes on to the lower eight bits of the address bus. The first thing we need, then, is a decoder to convert the binary data to a discrete control line for each port address we are using.

The micro also sets a control line — "I/O" — when the address bus is carrying a port address. This signal is gated with each port-select line to enable the correct port at the proper time. Finally, the Z-80 generates "READ" and "WRITE" control signals. They can be used to link the correct port to the data bus. You can see from figure 9 that port 1 is used for both input and output — it is thus controlled by the "READ" and the "WRITE" lines. Further, there are two Port 3s. One is an input device; the other is an output. The control lines select the correct chip every time. The ports are normally special LSI peripheral chips, but could be much simpler, e.g., latches.

**Demonstration program.** Let us make a short program to use some of the Z-80 I/O functions. Suppose a Z-80 is servicing four ports. The ports have consecutive addresses, and represent two input channels. In each channel, one port carries status information, and the second has the data, which is in two's complement from — figure 10.

The two status ports are I/O ports. The

Table 1. This month's instructions for Z-80.

Operation	Mnemonic	Flags	Effect
Conditional Call	CALL c,a	None	PC = a if condition satisfied
Conditional Return	RET c	None	PC = Return Address if condition satisfied
Exchange top of Stack and HL	EX (SP), HL	None	L = (SP); H = (SP + 1) (SP) = L; (SP + 1) = H
Direct Implied Input	IN A,(N)	None	A = Port N
Direct Implied Output	OUT(N),A	None	r = Port(C)
Direct Input	IN r,(C)	S,Z, H,P/V	A = Port N
Direct Output	OUT(N),A	None	Port N = A
Implied Output	OUT(C),r	None	Port(C) = r

```

; DEMONSTRATION PROGRAM FOR Z80 "IN" AND "OUT"
;
POLL LD HL,C ; INITIALIZE COUNTS
LD C,STAT1 ; SET PORT POINTER
IN A,(C) ; READ STATUS1
BIT 7,A ; READY SST?
CALL NZ,STORE ; YES - HANDLE DATA
INC C ; POINT TO
INC C ; ..STATUS2
IN A,(C) ; RESPEAT
BIT 7,A ; ..FOR
CALL NZ,STORE ; ..CHANNEL2
LD A,10J ; ..FINISH
CMP B ; ..WHEN
JP Z,FINISH ; ..100 BYTES
C.P H ; ..FROM EITHER
JP NZ,POLL ; ..PORT
FINISH NOP ; ON TO NEXT SEGMENT
;
;
STORE INC C ; POINT TO DATA PORT
IN B,(C) ; READ IT
DEC C ; POINT TO STATUS PORT
SET 6,A ; COMPLETE
OUT (C),A ; HANDSHAKE
RES 6,A ; ..WITH A
OUT (C),A ; ..PULSE
BIT 7,B ; SIGN OF B
RET NZ ; RETURN IF B NEG
; AT THIS POINT, THE MSB OF B IS ZERO
; SET IT TO SHOW WHERE DATA CAME FROM
LD A,STAT1+2 ; A=STATUS 2
CAP C ; CHANNEL ??
CALL Z,MARK ; MARK IF CHANNEL2
INC B ; TOTAL 1
; RETURN TO NEXT INSTRUCTION FROM "MARK"
LD A,B ; SET MASK
AND B ; TRUNCATE B INTO A
OUT (FILE),A ; SAVE A
RET
;
; SUBROUTINE TO SET MSB OF B TO "1"
;
MARK SET 7,B ; SET MSB
INC H ; TOTAL 2
EX (SP),HL ; INCREMENT RETURN
INC HL ; ..ADDRESS TO
EX (SP),HL ; ..MISS "INC L"
RET

```

Figure 12.

MSB — bit seven — shows when data is ready, and the Z-80 can output a handshake from bit six. The data ports are input-only.

The program must poll the two channels. Whenever one has data ready, it is to be read and acknowledged. If the data is negative, it is to be ignored, otherwise the six lower bits are output to another port at address "FILE". That could be a floppy-disc unit. The data can be in any sequence from the two channels. The two sources are to be identified to "FILE" by setting the MSB of data from channel 2 to 1. Data from channel 1 has its MSB left at 0.

Finally, when 100 bytes have been received from either channel, the program is to finish. Figure 11a is a flowchart for that; you can see it uses the subroutines in figures 11b and 11c.

Figure 12 shows the resulting program. Registers H and L are used to form "TOTAL1" and "TOTAL2" respectively. The basic polling loop uses the implied "IN", so that the program can calculate the port address. This loop could obviously be extended to any number of ports with only a few more instructions.

Conditional calls to the "STORE" subroutine simplify the polling loop; when "STORE" is called, C still contains the port address.

"STORE" manipulates C to read the data, and then to output the handshake pulse. A conditional return ends this routine if the input data is negative. If the data is valid, and from channel 2, a call to "MARK" is made. This sets the MSB of the data in B to "1" to identify the channel. "MARK" also increments "TOTAL2".

# Apple COS: prompts and utilities

ONE PROBLEM touched briefly in the section on COS output bug in the June 1980 issue is that of recognising when we are in command mode in whatever language. It was asserted that command mode can be recognised by the sequence 'retn' followed by 'prompt', where 'prompt' is the contents of location 33H.

That is true in the sense that all the languages follow that pattern in command mode — but so do the Basic input statements, especially if the operator responds to the input with a CTRL-X.

I understand that early versions of Apple DOS suffered from the problem, having a tendency to interpret String INPUTs as DOS commands. If we are to find a satisfactory solution, we will need to know what characters are used as prompts. Here is a program to display the contents of 33H, in Hexadecimal, whenever keyboard input is expected.

```
*F666G      start assembler.
!300: LDA #0
! STA 22      not necessary if you re-set
              before running this.
! JSR FC58    clear screen.
! INC 22      move top of scrolling
              window down one line.
! INC 25      move cursor down into
              window.
! LDA #3      we are working in page
              three.
! STA 39      change the input vector to
              point to 31B.
! RTS        30F
!31B: PHA     save accumulator contents.
      PHP     and processor status.
! LDA 24      save Cursor Horizontal
      PHA     position.
! LDA 28      BASL: low byte of address
              of start of current line.
! PHA         save it.
! LDA 29      and BASH, the high byte.
      PHA         325.
! LDA #0      CH = 0
! STA 24      BASL = 0
! LDA 28      page four : start of video
      LDA 4      RAM.
! STA 29      BASH; BAS is now 400.
! LDA 33      prompt.
! JSR FDDA    print Hexadecimal code for
              prompt.
! PLA        335.
! STA 29      restore BASH.
! PLA
! STA 28      and BASL.
! PLA
! STA 24      and CH.
! PLP        and processor status.
! PLA        and finally accumulator.
! JMP FD1B    go to normal keyboard
              input routine.
! (Reset)
```

\*300G connect as an input 'bug'.  
The screen should now clear, and display AA

In the top-left-hand corner. 'AA' is the Apple Hex code for \*; ASCII \* is 2A, and Apple sets the high bit for normal video display. Now start the assembler, and note the change in the code displayed. Try

the two versions of Basic — remember, every time you use re-set the 'bug' will be disconnected, so follow it with \*300G — and write a short program in each:

```
10 INPUT A
20 INPUT "HELLO",A (";" instead of ","
30 INPUT AS      IN FP)
40 INPUT "HELLO",AS (.....)
50 END
```

In Integer Basic, the input prompt is BF ("?"), even when the apparent prompt is "HELLO"; and in FP input prompt is 80 — CTRL—@, which is a non-printing character — even though INPUT A will print a "?".

Responding to an input with CTRL-X always produces the sequence 'backslash' 'retn' 'prompt', no matter which language you are in — and COS, so far, would recognise this as 'command mode' — while using the backspace key produces 'retn' 'prompt' in all languages other than FP — which gives only the 'prompt'.

The genuine command prompts are AA — monitor — A1 — assembler — DD — FP — and BE — INT. It is not immediately obvious how one could, with a

by Hugh Dobbs

single test, distinguish between these and the input prompts. Probably the easiest way will be to test for BF and for 80 individually whenever a prompt occurs.

That will disable COS commands during Basic inputs, but any future languages will have to use BF or 80 for their equivalent of input or else COS will need further patching.

The absence of a source-code listing for either of the Basics is a serious disadvantage if you are trying to find out how the input and get routines work, and at other times, so I use a general-purpose ROM-searching program to help in decoding them.

It is not intended to coexist with anything other than the monitor, and uses at least the first six zero-page locations; only two of them are essential. Locations zero and one hold the address in ROM which is being searched, location two is the number of bytes to be matched minus one, locations three and following hold the bytes for which we are searching.

The program is written to run in page 3, but is re-locatable, apart from one sub-routine call which would need to be changed:

```
!300:LDA C080;  FPRom select FP ROM
              board.
! LDA #0      clear low address
              byte.
! STA 0;      LOCL
! LDA D0;     FPSTART D000 is start of
              (continued on next page)
```



## Milequip Ltd.

commodore  
APPROVED DEALERS  
BUSINESS COMPUTERS  
SALES AND SERVICE  
7A HARE LANE  
GLOUCESTER  
CALL US FOR INFO OR DEMO  
059-451 624  
MANY BUSINESS PACKAGES

• Circle No. 208

## apple II in sussex

oval computer systems

Elm Park, Ferring, Worthing, West Sussex tel: 0903-44831  
198 Church Road, Hove, East Sussex tel: 0273-558299

• Circle No. 209

## WE HAVE MP/M UP AND RUNNING ON Z2H

Our expertise is now for  
sale Ring T C S LTD on  
01-556 1226

• Circle No. 210

## TRS 80 GOODIES!

LIGHT PEN — SIGHT TO YOUR  
MICRO! INCLUDES SOFTWARE  
ETC — £16 GREEN SCREEN?  
ADD £2.50

CLOADER — EASIER TAPE  
LOADING. GET THE VOLUME  
RIGHT EVERYTIME £9

SOUNDBOX — SOUND  
OUTPUT FOR TRS80 INC FREE  
M/C OUTPUT LISTING £10  
COSMIC PATROL — WITH  
SOUND! A M/C PROGRAM.  
PAST, GREAT GRAPHICS £14

B.J. AMBROSE  
15 ELM SHAW RD.  
PUTNEY, LONDON, SW15  
MAIL ORDER ONLY

• Circle No. 211



## SURREY MICROS LIMITED

for  
**APPLE II and now  
MICROSTAR**

together with a full range of  
business software

Contact:  
**Raymond H. Bowesman**  
Tel: Godalming 22318

• Circle No. 212

## EXIDY SORCERER

48K £849 + VAT  
32K NOW ONLY £799 + VAT

Dealer for

## Bristol and South West

ELECTROPRINT (Mr. Tasker)

5 Kingsdown Parade • Bristol 6 • 292375

• Circle No. 213

## Business Systems Systems Development

Programs designed  
and written for North Star  
and CP/M computer systems

### Consultancy

- Feasibility studies
- Independent advice
- Project management
- Single source supply of complete systems.

We specialise in accounting,  
order processing, invoicing  
and stock control systems.

**McMillan Computing Services**  
3 Tithebarn Grove  
Calcot, Reading  
Tel: 0734 414751

• Circle No. 214

## EPROMPT ERASER



- CLEARS UP TO 32 CHIPS IN 30 MINS ON 200-250V A.C.
- CONTINUOUS 253.7nm BEAM, SAFE & SIMPLE, GUARANTEEED
- £39 C.W.O. £40 C.O.D. • P&P+VAT INCLUSIVE !
- TRADE ENQUIRIES INVITED FOR SUBSTANTIAL DISCOUNTS  
ALL ORDERS AND ENQUIRIES POST-FREE TO:

**TEX MICROSYSTEMS LTD.**

FREEMPOST, ST. ALBANS, HERTS. AL1 1BR  
TRING 4797/ST. ALBANS 64077 ANYTIME

• Circle No. 215

(continued from previous page)

FP.

! STA 1; LOCH  
! JSR 324; TO- change this if re-  
SEARCH locating.

! LDS#0  
! LDA #2A; STAR black-on-white  
star.

! JSR FDED; STARS print a star.

! INX  
! CPS #4 four stars yet?

! BNE 312; TOSTARS  
! JSR F94A; PRBL2 print four spaces.  
! LDA C081; INTROM select on-board  
ROM.

! LDA#E0; INT- INT starts at  
START E000.

! STA 1; LOCH  
! LDY 2; SEARCH byte count minus  
one.

! LDA 3,Y; MATCH starting from end  
of pattern.

! CMP (0),Y match LOC + Y  
against 3 + Y.

! BNE 33C; TONEXT try next ROM  
-LOC location.

! DEY or next pattern  
byte.

! BPL 326; TO- if pattern not  
MATCH completed.

! LDA 1; LOCH 1/0 now point to  
start of the  
matching pattern  
(if any) in ROM.

! LDX 0 LOCL  
! JSR F941; PRNTAX print AX as four  
Hex numbers.

! LDX #4  
! JSR F94A; PRBL2 print four blanks.  
! INC 0; NEXT- point to next  
LOC ROM location.

! BNE 324; TO- try again ?  
SEARCH

! INC 1 next page.  
! BNE 324; TO- try again unless  
SEARCH FFFF passed.

! RTS

The pattern to be matched goes into  
locations three and following, so suppos-  
ing that you want to search for any occur-  
rence of the monitor subroutine call JSR  
GETLNZ, type in !3:JSR FD67 and then  
return to monitor. Since your pattern is  
three bytes in length, then \*2:2 store  
length-1 in location two. \*300G will then  
display any ROM addresses where this  
sequence occurs. The output in this case is

```
FF6D **** F599 FF6D
```

It shows that GETLNZ is called from  
the monitor (FF6D) and from the mini-  
assembler (F599). The monitor address  
appears twice because the monitor (F800  
to FFFF) is shared by INT and FP. If you  
have an autostart ROM on the FP board,  
it replaces the original monitor — but  
only a few parts of it are different, so in  
most experiments any address from F800  
onwards will appear both before and after  
the stars.

Pursuing the questions of input rout-  
ines and prompts, I have obtained the  
following results:

CALL etc.	CODE	MONITOR
JSR GETLNZ	20 67 FD	FF6D
JSR GETLN	20 6A FD	*
JSR NXTCHAR	20 75 FD	*
JSR RDCHAR	20 35 FD	FD75
JSR RDKEY	20 0C FD	FD2F,FD35
STA PROMPT	85 33	FF6B
STX PROMPT	86 33	*
INC PROMPT	E6 33	*
DEC PROMPT	C6 33	*

JSR E006	20 06 E0	N/A
JSR D52E	20 2E D5	N/A
JSR D52C	20 2C D5	N/A
INT	FP	ASM
*	*	F599
*	D530	*
E3D0,F351	*	*
*	*	*
*	D553,DC11	*
E006	*	F597
*	D52E	*
E180,E280	*	*
E185,E287	*	*
E2BA	N/A	N/A
N/A	D441	N/A
N/A	DBCf	*

The main points emerging from the in-  
vestigation — which took about half an  
hour, including the time spent checking  
for subroutine calls which do not exist at  
all — is the great variety of methods used  
to obtain input from the keyboard.

Yet all the methods ultimately use  
RDKEY and, therefore, pass through the  
indirect JMP (KSWL) at FD18. At that  
stage the input request is intercepted by  
the COS input bug. If the input used  
GETLNZ or GETLN or NXTCHAR, it is  
usually echoed on the screen by COUT —  
having been stored in the input buffer.

COUT uses the indirect JMP (CSWL)  
which is intercepted by the COS output  
bug. Thus command mode in all lang-  
uages affects both bugs; Basic input  
affects both; FP GET A and GET A\$  
affect only the input bug (JSR RDKEY);  
and output of all forms reaches the output  
bug.

Incidentally 'esc' and 'backspace' and  
'forward' are handled specially by the  
command and INPUT routines — 'back-  
space' alone is printed — but are treated  
as ordinary keys by FP GET.

I am going to leave the patch to exclude  
"?" and 'CTRL-@' as prompts until I  
have time for a major revision of COS,  
and pass on to fix the command decoder.  
This involves a re-definition of the bits in  
the operating-mode flag. The new defin-  
ition is:

879: OMODE Bits: M, W, R, C-D, — ,  
command, — , —

The bits immediately to the right of the  
'CTRL-D printout' and 'command mode'  
bits are now unassigned, and we can use  
them to indicate 'used to be C-D' and  
'used to be cmd' so that a simple LSR  
OMODE will cancel either of the two  
COS command modes without losing the  
information as to which mode it was. The  
changes needed to achieve this are tiny:  
\*D2:4 set 'command' bit as bit two not bit  
three.

\*D47:14 change COS? test accordingly.

Now to fit the LSR OMODE; we have a  
STA OMODE at D75 which will no longer  
be needed, but D75 is reached only if  
whatever has been typed or printed was  
not a COS command at all.

The logical place for the LSR is at the  
start of the command decoder, which is  
reached when a 'retn' follows any com-  
mand input, or CTRL-D output. That is  
at D53, so the whole block from D53 to  
D74 has to be moved three locations to



D56/D77:

\*1000<D53.D74M

move block to vacant area.

\*D56<1000.1021M

move it back to new locations.

this avoids the complete destruction which follows if you try to move it directly.

Any relative jumps — branches — within the block are unaffected by this move, but there are no branches into or out of the block which need to be adjusted, so all that remains is to insert the LSR OMODE:

\*D53:4E 79 08 no point in entering ASM for one operation.

The various language changes should now work if the appropriate commands are added to the table:

\*DEA:08 C2 D9 C5 1F (NOP) B Y E (E3F)

\*: CI D3 CD 1C 83 1A ASM (E39) CTRL-C (E35)

\*: C6 D0 0F C9 CE D4 0D FP (E1F) INT (E1B)

Connect COS, and try the new commands. We have still not finished with them. You may notice that the remainder of any input line is ignored: >FPTR = 7 for instance will switch to FP, which was probably not what was intended. Those commands form a special group — together with HELP — in two ways: they can be used only from the keyboard or from an EXEC file, and they cannot be followed by a number or a file name or any other parameter, since the languages are all in ROM.

Possibly CATALOG might be included in this group — for COS — since the question of drive and slot numbers does not arise. For this group — conveniently located together in the command table — we have to check OMODE to see if the mode was keyboard command, and call GETNSP to see if the next non-space character is a 'retn'.

Those two tests will be needed for most commands, so they should form part of the FOUNDIT! section of the command decoder. That will be a major revision and will involve exchanging FOUNDIT! and WRONG, putting GETNSP somewhere else, putting the WFCONT patch into the body of the program where it belongs, and possibly even re-locating the command table, to leave space for the necessary extension.

A major problem with cassette files is the corruption of tapes, usually through excessive use, e.g., games programs. Two types of trouble are particularly common — misread bits and dropped bits.

In the first case, as 1 is read as a 0 which will give an ERR message but the main body of the program will be readable — all you have to do is find the fault and correct it and, of course, save the corrected version quickly.

In the second case a 0 is not read at all, and all subsequent bits arrive one place too soon, so that all bytes after the drop-out have been effectively rotated one place to the left — the low bit of each byte being replaced by the high bit of the next byte.

If it is an INT program, it will list normally as far as the drop-out, and thereafter give a stream of rubbish which is still recognisably information. The end-of-program marker will have been corrupted along with everything else, so the list overruns the end of RAM and, on a 32K machine, starts reading non-existent memory — FF Hex, becoming '?' on LISTing.

The keyboard input addresses (0D), clicking the speaker, and finally switching to page two of video display before crashing altogether. An FP program LISTs differently, since FP uses absolute addresses for finding subsequent program lines.

Those addresses are now garbled, so LIST will finish the line it is working on do the next line as well and then take a random jump to somewhere else in memory and carry on from there so that the observed results have only a slight relation to the corrupted program. It is even possible for FP LIST to go into an infinite loop.

I have put a good deal of work into recovering corrupted programs — even re-constituting successfully the cassette version of Applesoft II by reversing the rotation. First you have to find the point where the drop-out occurred. Very often this is at the very first byte of the program where the monitor read routine skips a 0, intentionally, or two, accidentally.

If not, you have to scan through memory from monitor, starting at 800 for a ROM FP program or from — contents of CA and CB — for an INT program, until there is a break in the pattern.

For FP, (801,802) gives the address of the second line of the program; if you look there, you find the address of the third line and so on. When you reach an address that does not make sense, you have passed the drop-out point. If the line was a print or REM statement, FP stores the text as ASCII values, so do a quick scan for '20' bytes — spaces are the most common characters in text. Any '40' bytes suggest an error, since '@' is very rare. Other bytes less than 80 H are variable names; FP reserved words and punctuators are 80 or higher.

INT programs use displacements rather than absolute addresses; the first byte of each line gives the length of the line, so add that on to the current address to obtain the next one. The monitor will do this for you: \*8E + 2F low byte of current address plus offset = BD new low byte; but beware — it will not tell you if there has been an overflow — more than FF.

The end-of-line marker (01) should be immediately before the displacement, and the line number — two bytes in Hex — should follow it. Text in print and REM statements is stored as ASCII value plus 80 H; INT reserved words are less than 80, as are some punctuators.

If the end-of-line marker has become 02, or the new displacement is 80 H or

(continued on next page)



## LOGIC BOX HAVE THE COMPLETE SOLUTION

- Full range of APPLE and PET hardware
- Readymade software for
  - Accounting
  - Stock Control
  - Business Planning
  - Word Processing
- \* Professional advice and support

31 Palmer St,  
London SW1  
(near St James's  
Park Underground)  
Tel: 01-222 1122/2492



• Circle No. 216

## Apple-II in Scotland Core Data Systems Ltd

Suppliers of APPLE hardware and software.

We offer advice on the use of micro-computer systems, and undertake the design of systems to client's specifications.

Specialists in UCSD Pascal.

Now in new premises at:

101 COLINTON ROAD  
EDINBURGH EH14 1AL  
Phone 031-443 8710

Authorised APPLE Service Centre

• Circle No. 217

## CC MICRO SYSTEMS

Apple II Software Specialists

Free Demonstrations  
&  
Three Year Warranty

• Management Information System	£106
• Payroll	£156
• Mailing List	£16
• Complete Accounting System (Sales, Purchase & Nominal Ledgers Profit and Loss Account, Stock Control & Balance Sheet)	£350

For further details contact:

C.C.M.S., 48 Melrose Avenue, Penylan, Cardiff.  
Telephone: 0222 495257

• Circle No. 218

## PLUG IN RAM CARDS — SUIT ZX-80

Fully decoded ram cards, plugs directly into socket at rear of ZX-80. Just 1K extra gives up to 5 times the program area. The card will take up to 3K and has sockets to take the ram chips. FULLY INCLUSIVE PRICES.

1K ... £20 2K ... £30 3K ... £40

Send order to  
QUICKSILVA  
56 Bedford Place, Southampton,  
Hants.  
Or S.A.E. for further details

• Circle No. 219

## ADD FULL GRAPHICS TO YOUR VDU!

Does your VDU Home Computer use the Thomson SFF96364 VDU chip? (eg. Triton, Elekterminal) And do you want FULL GRAPHICS and LOWER CASE CHARACTERS? Then you need the AUTO ELECTRONICS 96364G GRAPHICS MODULE. When used in conjunction with the SFF96364 it gives access to the full 8x12 dot matrix per character not just 7x5. This allows ANY customised character set to be used (eg. Arabic) or graphics set or even high definition graphics. Character information is stored in EPROM (or even RAM) which completes the circuit. The module measures 4x4x1.3 cms. and consumes 20 mA at 5 volts. 96364G Graphics Module (with full data)

£12.65

96364GP Ready Build PCB with Graphics Module and socket for 2716/2708 EPROM (with full data)

£23.00

2716 (5volt) Custom Programmed with your Character set

£26.45

Prices include VAT and Postage. Write or phone for data.

AUTO ELECTRONICS,  
MOOREND GROVE,  
CHELTENHAM, GLOS GL53 0EX  
(0242) 515133 (after 6pm)

• Circle No. 220

Superboard-, UK101- and TRS-80-compatible

## COLOUR YOUR NASCOM!



DAZZLING COLOUR GRAPHICS FOR NASCOM 1 & 2

Genuine bit-addressable "pixel" system for straightforward programming of pictorial or mathematical functions.

8 Colour display plus 8 colour independent background facility. Full documentation with FREE SOFTWARE: powerful sub-routines for vector generation, demonstration program for animated effects. All runs in Nascom 1 without expansion. Complete with UHF Colour Modulator for operation with normal colour TV set. Superior design allows connection to most other micro-processor systems — send us diagrams etc of your B & W video circuitry for free advice. Don't be fooled by the price: this is a top quality product which will transform your computer.

NOW AVAILABLE FOR LIMITED PERIOD AT **£45 + VAT**

WILLIAM STUART SYSTEMS Ltd

Dower House, Billericay Road, Herongate, Brentwood, Essex CM13 3SD. Telephone: Brentwood (0277) 810244

• Circle No. 221

## MEREFIELD'S ELECTRONICS LTD.

We specialise in memory products — LOW POWER SCHOTTKY — T.T.L. — C-MOS etc.

Sales only, to MFGs and DSTBs (including retail shops).

Please note we have moved to new premises:

Merefields Electronics Ltd  
White Horse Lane  
Canterbury, Kent

Tel: 0227/64442/60604  
Telex: 965386

• Circle No. 222

(continued from previous page)

more, which would make it negative in a sense, you have probably passed the drop-out. Probably, because impacted machine-code programs are common both in my Basic programs and in the Apple demonstration programs, and they can break most of the rules.

Machine-code programs can be disassembled by using the monitor L command; if the program starts at 300 H, \*300L will display the first 20 instructions, and \*L thereafter will display the next twenty.

Unless there are any complications, there will be a sudden change from meaningful code to rubbish — "???" etc. The drop-out took place either where the rubbish starts, or at most one or two bytes earlier.

Once you have found the location of the drop-out, you have to rotate right the whole block from there to the end of the program. One or two bytes just at the drop-out point will probably need to be changed by hand, and the process may need to be repeated elsewhere.

Of course, if you make a mistake, the whole block has to be rotated left again, which is twice as complicated since you have to rotate the high bit of byte X + 1 into the low bit of byte X. Here are two programs to execute the two block rotations. For convenience, I have attached them to the monitor as two additional commands:

!300:PLP; LOOP R recover carry bit to rotate into bit seven.

! LDA (3C,X); ROR next byte for rotation.

! ROR rotate C → byte → C.

! PHP save carry bit for next time.

! STA (3C,X) store rotated byte.

! JSR FCBA; TO-monitor sub-NEXTA1 routine: add one

to first address pointer if it has not yet reached second address; if it has reached it, set carry flag. Rotation is complete if carry is set.

! BCC 300; TOLOOP recover carry, R and go on to next byte.

! PLP pop processor status from stack, leaving return address; then exit by

! RTS 30D

! LDA (3C,Y); ROL pick up byte

after (3C); Y = 1.

! ASL bit seven into carry bit.

! LDA (3C,X) pick up byte (3C); X = 0

! ROL ROTATE C ← byte ← C.

! STA (3C,X) store rotated byte; no need to save carry bit this time, as we are working backwards and it has already been used.

! JSR FCBA; TO- see above.

! BCC 30E; TOROL if not finished, do again.

! RTS otherwise exit. (31B).

! LDY 34; YSAV input buffer pointer (monitor).

! INC 34 point to next character.

! LDA 200,Y read character

! LDA #1 from buffer. see above (30E note).

! LDS #0 zero offset for indexing.

! CMP #BC; "<" rotate left?

! BEQ 30E; TOROL

! CMP #BE; ">" rotate right?

! CLC carry = 0 since that is probably what dropped-out.

! BEQ 30I; TOROR

! DEC 34 if the character read was neither < nor >, signal an error but do not otherwise interfere with monitor.

! JMP FF3A; TOBELL ring bell and return to monitor.

!3F8:JMP 31C connect new routines to monitor.

Here, I am using the monitor, not Basic, USR function which JuMPs to location 3F8 on reading a CTRL-Y from the input buffer. From 3F8 we go to 31C, where a test is performed to see if the character following the CTRL-Y is a < or a >.

If it is neither, the operator has made a mistake, so we restore the original value for the input buffer pointer and return control to the monitor. The < means rotate left, which is handled by the section from 30E to 31B.

The > means rotate right and is handled by 300 to 30D. In each case, the block to be rotated has been previously defined by inserting the starting address in 3C and 3D, and the finishing address in 3E and 3F. This is done easily by using the monitor itself within the command:

\*400.7FF"CTRL-Y" < will rotate left the whole of the video display. Replace "CTRL-Y" by CTRL-Y, of course.

To test, first clear the screen with esc @ and hit return; then:

\*22:1 protect top line of screen from scrolling.  
\*400:50 6A 64 64 E9 D0 64 E9  
\*: D0 69 67 EA 60 EA 62 E2 50 50

That will give a row of nonsense extending almost halfway across the screen, which is a code message. To decode it, type

\*400.411"CTRL-Y" < and see what happens. Either re-set or \*22:0

will restore the normal scrolling window. Incidentally, re-set does not kill the new monitor commands in the same way as it kills COS, because the use of USR is optional, and therefore the JuMP vector is not initialised by re-set.

In every block rotation, one bit is lost and one bit is gained. The left rotation causes the loss of the high bit of the first byte in the block, and the low bit of the last byte in the block is replaced by the high bit of the next byte immediately after the block.

Thus left rotations can be done a section at a time without much loss of information. The right rotation causes the loss of the low bit of the last byte in the block, and the high bit of the first byte is re-set to 0 on the supposition that it was the bit which dropped-out.

Thus right rotation — the one you will normally use — should be done to the whole program at one time, starting at the point where drop-out occurred or, in case of doubt, a few bytes earlier. □

# BUYERS' GUIDE

# Software

Software packages are listed by application, in alphabetical order, with the systems on which each package will run also listed alphabetically. The guide is not exclusively for business applications: if your company is the source or dealer for a package with a more unusual application, send us the details and we will create a new category.

The usual criteria have been applied. The minimum configuration is 32K of RAM, a disc and a printer; the price of the package must lie between £50 and £1,000; the companies listed are the source of the software or the main dealers in the U.K., and the capacity quoted is per disc or drive.

## Machine type by application

### Combined-Ledger/Stock/Invoicing

Machine Type	Supplier Name	Price	Capacity
Apple II	Vlasak Electronics Ltd	£855	
Apple II/ITT 2020	Informex London Ltd	£298	500 A/Cs
Commodore 3032	Compier Ltd	£400	varies
Commodore 3032	Bristol Software Factory	£300	1,000 A/Cs 6,000 trans
Commodore 3032	G W Computers Ltd	£275-- £575	1,000
Commodore 3032	Analog Electronics	£550	
Commodore 3032	Stage One Computers	£600	varies
Commodore 3032	Logma Systems Design	£600	1-6 shops
Commodore 3032	Commodore B M (U.K.) Ltd	£650	650 A/Cs/ledger
Commodore 3032	Compier Ltd	£600	500 A/Cs 1,000 items
CP/M	Minicomputer CS Ltd	£650	varies
CP/M	Computastore Ltd	£1,000	
CP/M	Minicomputer CS Ltd	£850	varies
CP/M North Star	Benchmark CS Ltd	£950	200 A/Cs 500 trans 300 items
CP/M North Star	Profcomp Ltd	P.O.A.	
CP/M North Star	Intelligent Artefacts	£510	1,500 A/Cs 5,000 trans



### APPLE/ITT 2020 TOP QUALITY SOFTWARE

**SUPER EDITOR.** A high-speed machine-code utility routine which lists out every Applesoft line containing a selected variable, Basic command or string, highlighting it in inverse characters and, if required, replacing it, either singly or throughout the program, by another variable, command or string (whatever their respective sizes). Invaluable for editing and debugging.

**PACKING SUITE** — Strips Rems from Applesoft programs (all references to deleted lines are properly renumbered).

— Packs statements together for maximum speed and optimum memory usage.

— Unpacks multi-statement lines for ease of editing. Each program is supplied on disk. (32K/48K).

Price — £27.50 each.

**BLUE CHIP SOFTWARE**  
10 Huson Close  
London NW3 3JW

• Circle No. 223

### TERMINAL ONE THE COMPLETE BUSINESS (05034) 574 (day) (0752) 23728 (evenings)

### TRS 80 / PET IT WON'T COST YOU ANYTHING

to read this — but could save you a lot.

We did not rush in to jump on the bandwagon, but decided to prove our products before putting them on the market — now after two years they are available to you.

Software Packages = > anything on the market — but much cheaper, and many other software and hardware goodies at low, low prices.

#### TRY THIS

### SMALL BUSINESS ACCOUNTING PACKAGE (TRS80)

available in modules are required  
**VAT INSPECTORATE &  
ACCOUNTANT APPROVED**  
designed with the small business in mind — but capable of handling the larger concern without difficulty

#### INCLUDES

Sales & Purchase Ledgers (open item), Nominal Ledgers, VAT Returns, Profit & Loss, Trading Accounts, Balance Sheet — plus many more features that you may require.

#### OTHER FEATURES

Statements (Aged), Aged Debtors Returns, Mailing Lists, Invoice Writer, Management Information System Etc.

#### ALL TOTALLY INTERACTIVE

Send large S.A.E. for Price list and any other information required.

To:— **Terminal One**  
**53, Ridge Park Avenue,**  
**Mutley, Plymouth, Devon.**

• Circle No. 224

### WE'RE SMALL

but we are VERY GOOD.  
We give personal service.  
**YOUR PROBLEMS SOLVED  
IF IT'S REAL SERVICE  
FOR SHARP • NASCOM  
OR NORTH STAR  
C.J.R.**

**MICROTEK LTD.**

**PHONE CHRIS ROBINSON ON  
IPSWICH (0473) 50152.**

• Circle No. 225



## APPLES GET MORE TO THE POUND

From complete business packages, bespoke software and consultancy to personal systems, peripherals and games.

**Atlanta Data Systems**  
01-739 5889

• Circle No. 226

### S100

- BOARDS —
- CABINETS —
- DISC DRIVES —
- MOTHERBOARDS —
- COMPLETE SYSTEMS —
- ASSEMBLED AND TESTED
- SOFTWARE —
- LOW PRICES —

PHONE OR WRITE FOR CATALOGUE

## RATIONAL SYSTEMS

**Cedar House, Union Street**  
**Newport Pagnell,**  
**Bucks MK16 8ET**  
**Tel: 0908 613209**

• Circle No. 227

## PROBLEMS WITH MICROS?

WE CAN OFFER —

Program design and development  
Independent advice on micros  
Solutions to interface problems  
FOR BUSINESS AND INDUSTRIAL  
APPLICATIONS Phone 0222 882160

## CURRENT ELECTRONICS

50, BOURNE ROAD,  
BROMLEY, KENT, BR2 9NS.

• Circle No. 228

## The Dream Machine

Fantasy, fact and fiction  
with the

### COMPUCOLOR II

Micro system with 64 colour combinations

Prices from £1200 with micro floppy

**COPERNICUS (0428) 52888**  
**7 Wey Hill, Haslemere, Surrey.**

• Circle No. 229

CP/M North Star Metrotech System	Instar Business Systems Metrotech	£999 £500- £1,000	600-2,900
Ohio Scientific Tandy TRS-80	Microcomputer B M Microcomputer Applications	£656 £190 each	
Tandy TRS-80	T & V Johnson Ltd	£110	750 trans/disc
Tandy TRS-80	Microcomputers Applications	£350	
TECS	Jar Software Systems	£650	500 A/Cs 300 nom A/Cs
Z-80/8080	Graffcom Systems Ltd	£995	
Z-80/8080	Great Northern C S Ltd	£995	varies

## General Ledger

Machine Type	Supplier Name	Price	Capacity
Apple II	Vlasak Electronics Ltd	£225	200 A/Cs 1,000 trans
Apple II	Computech Systems	£295	500 A/Cs 1,700 trans
Apple II/ITT 2020	Systematics International Ltd	P.O.A.	
Commodore 3032	Analog Electronics	£450	
Commodore 3032	HB Computers Ltd	£200	Linked to S/L & P/L
Commodore 3032	Bristol Software Factory	£300	1,000 A/Cs 6,000 trans
CP/M	Haywood Associates Ltd	£500	
CP/M	Median-Tec Ltd	£500	500 A/Cs 600 trans
CP/M	Computastore Ltd	£500	999 A/Cs 99 centres nine companies
CP/M	Ludhouse Ltd	£500	200 A/Cs 5,000 trans
CP/M	Comput-A-Crop	£400	
CP/M	Benchmark CS Ltd	£250	500 A/Cs 5,700 trans
SD100/200	Barcellos Ltd	£250	
Tandy TRS-80	Tridata Micros Ltd	£225- £375	500 A/Cs 1,000 trans
Z-80/8080	Great Northern C S Ltd	£275	varies
Z-80/8080	Graffcom Systems Ltd	£390	

## Incomplete Records

Machine Type	Supplier Name	Price	Capacity
Apple II	Personal Computers Ltd	£250	1,000 trans 2,600 A/Cs
Apple II/ITT 2020	Padmede Computer Services	£450	900 A/Cs 2,000 trans/disc
Commodore 3032	Stage One Computers	£750	500 centres 2,300 A/Cs
Commodore 3032	Micro Computation	£555	120 A/Cs 5,000 trans
CP/M	Profcomp Ltd	P.O.A.	2,000 entries
Durango F85	Kesho Systems	£1,000	
Exidy Sorcerer	Basic Computing	£350 incl.	see also Micropute

## Job Costing/Billing

Machine Type	Supplier Name	Price	Capacity
Apple II/ITT 2020	Padmede Computer Services	£300	1,000 A/Cs 99 centres
Apple II/ITT 2020	Padmede Computer Services	£300	150 A/Cs
Commodore 3032	Stage One Computers	£100	300 appointments
Commodore 3032	CSM Ltd	£600	1,000 jobs 100 people
CP/M	Graffcom Systems Ltd.	P.O.A.	100 activity codes
Z-80/8080	Great Northern C S Ltd	£300	varies

## Mailing Systems

Machine Type	Supplier Name	Price	Capacity
Apple II	Kenn Computers Ltd	£300	500 addresses
Apple II/ITT 2020	Systematics International Ltd	£300	500 addresses
Apple II/ITT 2020	Guestel Ltd	£190	400 addresses
Apple II/ITT 2020	The Software House	£57	750 names & adds
Commodore 3032	Stage One Computers	£100	350 records
Commodore 3032	MMS Computer Systems	£250	3,000 records
CP/M	Graffcom Systems Ltd	£250	varies



CP/M	Median-Tec Ltd	£500	
CP/M	Structured Systems Group	£50	varies
CP/M Horizon	Microtek Computer Services	£500	varies
CP/M North Star	Micromedia Systems	£195	
Tandy TRS-80	Comput-A-Crop	£78	varies
Tandy TRS-80	Cleartone ADP	£50	660 entries
Tandy TRS-80	T & V Johnson Ltd	P.O.A.	3,000 names/addresses
Z-80/8080	Micro Focus	£90	varies
Z-80/8080	Intereurope S D Ltd	£500	3,000 entries

## Payroll

Machine Type	Supplier Name	Price	Capacity
Apple II/ITT 2020	T W Computers Ltd	£145	
Apple II/ITT 2020	Informex London Ltd	£50	
Apple II/ITT 2020	Informex London Ltd	£198	200 employees
Apple II/ITT 2020	Algobel Computers Ltd	£295	500 employees
Apple II/ITT 2020	Vlasak Electronics Ltd	£360	
Apple II/ITT 2020	Minster Micro System	£199	100 month 50 weekly
Apple II/ITT 2020	Computech Systems	£379	300 employees
Commodore	Petsoft Ltd	£50	200 employees
Commodore 3032	Landsler Software	£95 incl.	200 employees
Commodore 3032	Commodore B M (U.K.) Ltd	£150	200 employees
Commodore 3032	Analog Electronics	£90	
Commodore 3032	ACT (Petsoft) Ltd	£195	600 employees
Commodore 3032	L & J Computers	£220	
Commodore 3032	Intex Datalog Ltd	£195	200 employees
Commodore 3032	Computastore Ltd	£200 & £350	275 & 500 employees
CP/M	Haywood Associates Ltd	£350	
CP/M	Median-Tec Ltd	£500	
CP/M	Selven Ltd	P.O.A.	
CP/M	Graftcom Systems Ltd	£500	250 employees
CP/M	PCL Software Ltd	£600	800 employees/MBYTE
CP/M	Ludhouse Ltd	£450	300 employees
CP/M	Comput-A-Crop	£450	
CP/M Horizon	Microtek Computer Services	Lease	varies
CP/M North Star	Micromedia Systems	£495	350 employees
Durango F-85	Kesho Systems	£500	
Sharp MZ-80K	Tridata Micros Ltd	£250	400 employees
Tandy TRS-80	A J Harding (Molimerx)	£95-£200	
Tandy TRS-80	Tridata Micros Ltd	£218- £375	400 employees
Tandy TRS-80	3-Line Computing	£140	
TECS	Jar Software Systems	£250	300 employees
Z-80/8080	Graftcom Systems Ltd	£490	250 employees
Z-80/8080	Liveport Data Products	£250	500 employees

## Property Management

Machine Type	Supplier Name	Price	Capacity
Apple II/ITT 2020	Cyderpress Ltd	£650	500 properties; 420 applicants
Apple II/ITT 2020	Informex London Ltd	£298	300 entries
Apple II/ITT 2020	Algobel Computers Ltd	£650	400 buildings 250 Own 2,000 trans
CP/M	Algobel Computers Ltd	£650	2,000 trans
Z-80/8080	Graham Dorian Software	£325	varies

## Purchase Ledger

Machine Type	Suppliers Name	Price	Capacity
Apple II	Vlasak Electronics Ltd	£315	200 A/Cs 1,000 trans
Apple II	Computech Systems	£295	500 A/Cs 1,600 trans
Apple II/III 2020	Padmede Computer Services	£300	900 A/Cs 4,500 trans/disc
Apple II/III 2020	Systematics International Ltd	P.O.A.	
Commodore 3032	Microact Ltd	£350	2,000 A/Cs 7,000 trans
Commodore 3032	HB Computers Ltd	£350	800 A/Cs, 4,000 trans
Commodore 3032	Compfer Ltd	£300	1,000 A/Cs 7,000 entries

## APPLE & ITT 2020 BUSINESS SOFTWARE

Professionally written packages now available with comprehensive manuals, built-in validity checks, interactive enquiry facilities, user options, satisfying accountancy, Inland Revenue and Customs & Excise requirements. On diskette under DOS 3.2, in Applesoft with SPACE utility. Not adaptations. Written for Apple System. Support all printer interfaces. Sales, Purchases and General Ledgers £295-00 each.

Manual only £3.

Payroll £375. Manual only £4.

General Ledger supports Incomplete Records, Job Costing, Branch and Consolidated Accounts etc.

General Ledger Applications Manual £10.

Prices exclusive of V.A.T. From our shop or your nearest stockist.

**COMPUTECH SYSTEMS**

168, Finchley Road, London, N.W.3.

Tel: 01-794 0202

• Circle No. 230

## TANDY TRS-80 TEXAS TI-99/4 in Bedfordshire

**ELECTRON SYSTEMS**  
6, PARK ROAD, SANDY  
Telephone 0767-81195

• Circle No. 231

## NEW! NEW! NEW! NEW! NASCOMS 1 & 2 D/A NASBUS BOARD

two 8 bit converters, full scale outputs 2.5 - 5.0V.

from £69.50

INPUT/OUTPUT BOARD

up to 5 PIO devices

for more details SAE.

**BING SYSTEMS, 8 Glen Rd, Bingley, West Yorks, BD16 3ET.**

• Circle No. 232

## Nene College Northampton

**MICROPROCESSOR TECHNOLOGY**

A range of one-day-and three-day courses covering both hardware and software aspects.

Full details on application:

**Microprocessor Court Tutor**

**School of Technology**

**NENE COLLEGE**

**St. George's Avenue**

**NORTHAMPTON**

**NN2 6JB**

• Circle No. 233



**Functional Business Software on Cassette for  
TRS 80 LEVEL II 16K**

British Software written for British companies and now is in daily business use:

1) "BANK A/C" PROGRAMME  
21 column analysis, self totalling on all columns keeps full alpha and numeric records at command show's monthly and yearly totals to date, partners drawings, total o'heads to date, etc. £21.95.

2) "SALES LEDGER"  
Full record for a month, 17 entries for each invoice, plus totals 8 columns, searches and totals individual accounts, weeks sales, months individual heading totals, displays entire files £35.

3) "ORDERS FILE" PROGRAMME  
Searches by name, order no., customer order no., agent. Running totals of orders still in hand, totals agent sales, etc., displays entire file £14.95.

4) "IMPORTERS, COSTING AND SELLING PRICE" PROGRAMME! £9.95.

All programmes include practical instructions! Tailored Software available. Packing & V.A.T. INCLUDED.  
ACCESS COMPUTERS 2 Rose Yard, Maidstone, Kent ME14 1HN Tel: Maid. (0622) 58356

• Circle No. 234

**SHARP PC1211  
POCKET COMPUTER  
ONLY £97.75 INCL. VAT & P/P**

Includes: Applications Manual (over 80 programs). Beginners "BASIC" Textbook and Instruction Manual.

CE-121 Cassette Interface £13.25  
PC1211 SOFTWARE!

SHARP SUPERSET 1. £7.95  
(Fever, Simon, Russian, Lunar, Cave, and Days)

SHARP SUPERSET 2. £7.50  
(Futures, Juggler, Chopper, Snakes, and Spider)

Make Cheques/P.O.'s payable to:—

**S & J Computer Sales**  
25 Lynton Crescent,  
Gants Hill, Ilford, Essex.

Send s.a.e. for full details.

Allow 28 days for delivery of PC1211

Allow 14 days for delivery of Software

FULL Service Guaranteed. All prices include VAT & P/P.

• Circle No. 235

**SUPERBRAIN  
SYSTEMS**

*STOCK CONTROL	£350
*SALES LEDGER	£350
*PURCHASE LEDGER	£350
*INVOICING	£200
*NOMINAL LEDGER/MAN: ACCOUNTS	£500
*BILL OF MATERIALS	£450
*MAIL ORDER SYSTEM	£450
*INCOMPLETE RECORDS	£750

Most items in stock  
2% discount for cash with order  
Dealer terms available

Contact:—  
**THE MICRO SOLUTION**  
Park Farm House, Heythrop  
Chipping Norton, Oxon, OX7 5TW  
Tel: (0608-3256)

• Circle No. 236

**JANE COATES ASSOCIATES**

**PROGRAMMING STATIONERY**

BASIC Coding sheets ..... £2.60 per 100  
Screen design sheets (80 x 25) ..... £2.20 per 100

**BOOKLETS on BASIC Programming**

BEGIN WITH BASIC ..... £2.00  
DATA FILES ON CASSETTES ..... £4.00

**SOFTWARE IN BASIC (8x PET CASSETTES)**

SURGERY BOOKINGS ..... £15.00  
INSURANCE DATA BASE ..... £35.00  
STOCK INVENTORY ..... £15.00  
HOTEL ROOM BOOKINGS ..... £26.00

**BASIC TRAINING COURSES**

Private courses on PETS  
Afternoons and evenings. Write for details.

All prices include VAT & P/P.  
Send chs/pos to:—

**JANE COATES ASSOCIATES,**  
28 St. MARKS ROAD  
MAIDENHEAD, BERKS. SL6 6DE.

• Circle No. 237

Commodore 3032	ACT (Petsoft) Ltd	£120	200 A/Cs 700 trans
CP/M	Haywood Associates Ltd	£350	
CP/M	Median-Tec Ltd	£500	500 A/Cs 600 trans/ACs
CP/M	Structured Systems Group	£460	varies
CP/M	Ludhouse Ltd	£500	500 A/Cs 5,000 trans
CP/M	Comput-A-Crop	£400	500 A/Cs
CP/M	Computastore Ltd	£400	500 A/Cs 3,100 trans
CP/M North Star	Benchmark CS Ltd	£250	500 A/Cs 2,000 trans
Durango F-85	Kesho Systems	£500	
Exidy Sorcerer	Basic Computing	£125 incl	See also Micropute
SD-100/200	Barcellos Ltd	£250	
Tandy TRS-80	AJ Harding (Molimerx)	£225	1,100 entries
Tandy TRS-80	Tridata Micros Ltd	£225-	
		£375	125 A/Cs 1,000 trans
Z-80/8080	Great Northern CS Ltd	£275	varies
Z-80/8080	Graffcom Systems Ltd	£440	

**Records Management**

Machine Type	Suppliers Name	Price	Capacity
Apple II	Courtman Micro Systems	£106	100K Characters
Apple II/ITT 2020	Diskdean Ltd	£120	varies
Apple II/ITT 2020	Systematics International Ltd	£125	1,000 references
Apple II/ITT 2020	Informex London Ltd	£198	500-1,200 records
Apple II/ITT 2020	T & V Johnson Ltd	£95	112K per drive
Apple II/ITT 2020	Systematics Intl Ltd	£72 & £175	
Apple/ITT 2020	The Software House	£140	900 records
Commodore 3032	CPS (Data Systems) Ltd	£200	varies
Commodore 3032	Amplicon MS Ltd	£140	1,500 records
Commodore 3032	Compsoft Ltd	£95-£170	600-5,000 records
Commodore 3032	Microact Ltd	P.O.A.	400K-800K
Commodore 3032	Commodore BM (U.K.) Ltd	£150	650
Commodore Pet	Stage One Computers	£130-	
		£250	165K
CP/M	Clenlo Computing Services	£90-£325	varies
CP/M	Median-Tec Ltd	£500	
CP/M SWTPC	Verwood Systems		
Metrotech System	Metrotech	£200-	
		£1,000	
Ohio Challenger	U-Microcomputers Ltd	£175+	
Ohio Scientific	Microcomputer BM	£175	
SD-100/200	Barcellos Ltd	£500-	
		£1,000	
Tandy TRS-80	T & V Johnson Ltd	£200	
Z-80/8080	Structured Systems Group	£135	varies
Z-80/Cromenco	Xitan Systems Ltd	£850	4,000 records/disc

**Sales Ledger**

Machine Type	Suppliers Name	Price	Capacity
Apple II	Vlasak Electronics Ltd	£315	200 A/Cs 1,000 trans
Apple II	Computech Systems	£295	500 A/Cs 1,600 trans
Apple II/ITT 2020	Padmede Computer Services	£300	900 A/Cs 4,500 trans/disc
Apple II/ITT 2020	Systematics International Ltd	P.O.A.	
Commodore 3032	Microact Ltd	£350	2,000 A/Cs 7,000 trans
Commodore 3032	Anagram Systems	£320	500 A/Cs
Commodore 3032	ACT (Petsoft) Ltd	£120	200 A/Cs 700 trans
Commodore 3032	HB Computers Ltd	£350	800 A/Cs 600 trans/ACs
CP/M	Median-Tec Ltd	£500	500 A/Cs 600 trans/ACs
CP/M	PCL Software Ltd	£500	1,000 A/Cs/MByte
CP/M	Ludhouse Ltd	£500	1,000 A/Cs 5,000 trans
CP/M	Ludhouse Ltd	£1,000	
CP/M	Computastore Ltd	£400	500 A/Cs 3,500 trans
CP/M	Haywood Associates Ltd	£350	
CP/M North Star	Benchmark CS Ltd	£250	500 A/Cs 2,000 trans



Durango F-85	Kesho Systems	£500	
Exidy Sorcerer	Basic Computing	£125 incl.	See also Micropute
SD-100/200	Barcellos Ltd	£250	
Tandy TRS-80	Tridata Micros Ltd	£225-	
		£325	175 A/Cs 1,350 trans
Tandy TRS-80	AJ Harding (Molimerx)	£225	1,350 entries
TECS	Jar Software Systems Ltd	£550	500 A/Cs
Z-80/8080	Graffcom Systems Ltd	£440	
Z-80/8080	Great Northern CS Ltd	£275	varies

## Stock Systems

Machine Type	Suppliers Name	Price	Capacity
Apple II/ITT 2020	Microdigital Ltd	£225	625 items
Apple II/ITT 2020	Systematics Intl Ltd	£500	200-2,500 items
Apple II/ITT 2020	Vlasak Electronics Ltd	£285	
Apple/ITT 2020	The Software House	£80	800 items
Commodore 3032	SMG Microcomputers	£395-	
		£495	2,450-7,000 items
Commodore 3032	Logma Systems Design	£600	1-6 shops
Commodore 3032	L & J Computers	£230	
Commodore 3032	ACT (Petsoft) Ltd	£75	2,400 items 1,000 A/Cs
Commodore 3032	Comptel Ltd	£350	200 lines 20 bars
Commodore 3032	Microact Ltd	£350	2,500 items, 1,000 A/Cs
Commodore 3032	Bristol Software Factory	£300-	
		£360	2,300
Commodore 3032	Commodore B M (U.K.) Ltd	£150	650
Commodore 3032	Anagram Systems	£395	500-600 items 255 A/Cs
Commodore 3032	SA Systems	£650	300 records/disc
Commodore 3032	Petsoft Ltd	£50	2,500 items
Commodore 3032	L & J Computers	£60	500 items
Commodore 3032	Rockliff Brothers Ltd	£120	3,900 items
Commodore 3032	Stage One Computers	£100	650 items
CP/M	Haywood Associates Ltd	£350	
CP/M	Median-Tec Ltd	£500-	
		£800	
CP/M	Graffcom Systems Ltd	£350	520-6,000 items
CP/M Cromemco	Micromedia Systems	£1,000	
CPM/Horizon	Microtek Computer Services	£1,000	varies
CP/M North Star	Benchmark CS Ltd	£450	1,000 items 750 trans
Exidy Sorcerer	Basic Computing	£125 incl	See also Micropute
Tandy TRS-80	Microgems Software	£150	1,000-2,000 items
Tandy TRS-80	A J Harding (Molimerx)	£225	630 items
Tandy TRS-80	Cleartone ADP	P.O.A.	
Tandy TRS-80	S A Systems	£650	300 stock records
Tandy TRS-80	T & V Johnson Ltd	£115	1,000 items
Tandy TRS-80	T & V Johnson Ltd	£145	1,000 items/invoices
Tandy TRS-80	Tridata Micros Ltd	£200-	
		£375	630 items/disc
TECS	Jar Software Systems	£800	10,000 items 5,000 orders
TECS	Jar Software Systems	£850	1,000 items 300 A/Cs
Z-80/8080	Graham Dorian Software	£325	varies
Z-80/8080	Rogis Systems Ltd	£500	900-3,500 items
Z-80/8080	Great Northern C.S. Ltd	£275	varies
Z-80/8080	Graffcom Systems Ltd	£340	
Z-80/8080	Graffcom Systems Ltd	£580	
Z-80/MCZ	Software Architects Ltd	£600	varies

## Word Processing

Machine Type	Supplier Name	Price	Capacity
Apple II	Personal Computers Ltd	£150	17 A4 pages
Apple II/ITT 2020	Vlasak Electronics Ltd	£120	
Apple II/ITT 2020	Systematics International Ltd	£75	
Apple II/ITT 2020	Guestel Ltd	£190	100K characters
Apple II/ITT 2020	Algobel Computers Ltd	£75	800 lines
Commodore 3032	Act (Petsoft) Ltd	£325	12,000 bytes
Commodore 3032	Act (Petsoft) Ltd	£325	12K bytes

## SUPERBOARD II

STILL the best value in home computers. Just compare the features:

- 8K floating point BASIC in ROM
- Full ASCII keyboard
- Standard cassette/TV interface
- RS232 printer interface
- 4K user RAM
- Expandable to 32K and dual mini-floppy
- Full range of OHIO Computers carried.

AVAILABLE NOW FROM:  
C.T.S.

31/33 Church Street  
Littleborough  
Lancs OL15 8DA  
PLEASE RING OR WRITE FOR  
LATEST PRICES  
Tel: Littleborough (0706) 74342  
or 79332 any time

• Circle No. 238

## BLOWER UNIT FOR TRS-80

... with a low-cost, quiet-running blower unit. Although designed for the TRS-80 it can be adapted for use on other micros. Prices, Excluding V.A.T.

Complete Blower Unit Kit £43.60p  
Blower Unit with Keyboard, Airbox only. £26.00

Keyboard Airbox £15.80p  
Expansion Interface Airbox Kit £17.60p  
P&P £1.20 on all items.

SAE for details  
Perlit Engineering Development Ltd,  
Balgay House, Inchture, Perthshire.  
Tel: (082-886) 242.

• Circle No. 239



for SHARP

WE WILL TRY TO MATCH  
BEST PRICES ANYWHERE  
— RING STEVENAGE  
(0438) 56049 FOR  
QUOTATION

## King Pin Computers

UNIT 38  
WEDGWOOD WAY  
STEVENAGE  
HERTS

• Circle No. 240

## IBM GOLFBALL PRINTERS From £425 + VAT



Reconditioned printers with keyboard and RS232 interface.

Sales — Service — Supplies

AID Office Supplies

Brindiwel Ltd.,  
Frampton Cotterell  
BRISTOL

Telephone: Winterbourne (0454) 774564

• Circle No. 241

### PEDRO COMPUTER SERVICES

#### THE SOFTWARE AND HARDWARE DESIGN PEOPLE

We offer maintenance contracts to dealers without technical support and individual micro systems users for CBI systems, APPLE systems, IIT systems

NEW Don't wear your PET keyboard: PCS offers CB-2 Soundbox with joystick for Space Invader. Price: £25.00

CB-2 Soundbox: Plugs into PET's User Port and Cassette Port. Works on old Roms and new Roms and on any size of PET. Comes complete with programming instructions and Demo Programs on cassette. Easy to program to generate music and different types of sound effects.

Features: Build-in Amplifier, Volume Control; 1 meter PET to Soundbox connector cable.

Options: Battery connector (on request only). Price: £20.00

RS-232/TTL Interface

Converts TTL to RS 232, RS 232 to TTL: Two separate circuits. Requires -12 and +12 Volt power supply. Price: £15.00

4channel A/D Converter: Add games paddle to PET. Control temperature. Remote control the world with 4channel A/D converter. Comes complete with Drive Program. Price: £80.00

66 Gable Crescent, Kenton, Middx. HA3 9LB

(Mail Order Only)

41 Brockley Rise, London SE23. Tel. 01-291 4734

• Circle No. 242

## PETER SCOTT FOR APPLE

### SHARP MZ 80K • PC1 211 TEXAS SALES & SERVICE

Computer books, stationery, floppy discs, tapes etc.

Ring or call and discuss your requirements

PETER SCOTT (EXETER) LTD.,

76-78 SOUTH STREET  
EXETER

Exeter 73309/56633

• Circle No. 243

## MICROLINE 80

\*\*\* £435.00 \*\*\*

Special offer for this fantastic matrix printer. Produces high quality print and Prestel/Tandy style graphics. 3 Print sizes, line programmable. Standard version has friction and pin feed. Centronics type interface optional serial interface. Including standard roll paper dispenser.

Special Price (Oct/Nov) £435.00 + VAT  
Tractor Feed £35.00 + VAT  
Serial Interface £71.50 + VAT

G.P.W. Electronics Limited  
55 Cobham Road  
Ferndown Industrial Estate  
Wimborne, Dorset  
Telephone 0202 893888  
Telex 417111

• Circle No. 244

Commodore 3032	Dataview Ltd	£159	
Commodore 3032	HB Computers Ltd	£70	39 A4 pages
Commodore 3032	Commodore BM (U.K.) Ltd	£75 &	
		£150	170 pages
Commodore 3032	Stage One Computers	£100	130 pages
CP/M	Median-Tec Ltd	£300	
CP/M	Computastore Ltd	£400	
CP/M	Southdata Ltd	£350	160,000 words.
CP/M North Star	Micromedia Systems	£495	
Ohio Scientific	Microcomputer B M	£116	
Tandy TRS-80	T & V Johnson Ltd	£109	10,000 words
Z-80/8080	Structured Systems Group	£120	varies
Z-80/8080	Intereurope SD Ltd	£500	varies

## Alphabetical list of suppliers

Supplier	Address	Sales contact
3-Line Computing 0482-445496	36 Clough Road Hull HU5 1QL	Tim Hill
Minster Micro Systems 04254-4751	88 Christchurch Road Ringwood, Hampshire, BH24 1DR	R Kilpatrick
ACT (Petsoft) Ltd 021-455-8585	Radclyffe House 66-68 Hagley Road, Edgbaston Birmingham	M Wauchope
Aerco-Gemsoft 04862-22881	27 Chobham Road Woking, Surrey GU21 1JD	Nigel Tylor
A J Harding (Molimerx) 0424-22039	28 Collington Avenue Bexhill-on-Sea, East Sussex	John Harding
Algobel Computers Ltd 021-233-2407	33 Cornwall Buildings Newhall Street, Birmingham B3 3QR	Steven Linden
Amplicon M S Ltd 0273-562163	143A Ditchling Road Brighton, Sussex BN1 6JA	Jim Hicks
Anagram Systems 0403-68601	9 Michell Close Horsham, West Sussex RH12 1JT	Jon Quigly
Analog Electronics 0203-417761	47 Ridgeway Avenue Coventry	
Barcellos Ltd Leicester 26584/5	Kimberley House Vaughan Way, Leicester	K Tapp
Basic Computing 0535-65094	Oakworth Road Keighley, West Yorkshire BD22 7LA	Mike Collier
Benchmark CS Ltd 0726-61000	Tremena Manor Tremena Road, St Austell Cornwall PL25 5QG	S Willmott
Bristol Software Factory 0272-20801	Micro House St. Michael's Hill, Bristol BS2 8BS	W J Kyle-Price
Clearstone ADP 0495-244555	Prince of Wales Industrial Estate, Abercarn, Gwent NP1 5RJ	E Balding
Clenlo Computing Services 01-653-6028	15 South View Court The Woodlands, Beulah Hill, London SE19	T Froud
Commodore B M (U.K.) Ltd 0753-74111	818 Leigh Road Trading Estate, Slough, Berkshire	Nick Green
Compfer Ltd 0772-57684	Preston Computer Centre 6 Victoria Buildings, Fishergate, Preston, Lancashire	D Steele
Compsoft Ltd 0483-39665	Old Manor Lane Chilworth, Guildford, Surrey	Nick Horgan
Comput-A-Crop 01-771-0867	32 Whitworth Road London SE25 6XH	Jenny Wilson
Computastore Ltd 061-832 4761	16 John Dalton Street Manchester	David Nicholson
Computech Systems 01-794-0202	168 Finchley Road London NW3	Laurence Payne
Courtman Micro Systems 0222-495257	48 Melrose Avenue Penylan, Cardiff	G Stuckey
CPS (Data Systems) Ltd 021-707-3866	Arden House 1102 Warwick Road, Acocks Green, Birmingham B276BH	N Ashbourne
CSM Ltd 021-382-4171	Refuge Assurance House Sutton New Road, Erdington, Birmingham B23 6QX	Peter Mart





Cyberpress Ltd  
0491-37769  
Diskdean Ltd  
01-242-7394  
Diskwise Ltd  
05793-3780  
Equinox Computer Systems  
01-739-2387/9

G W Computers Ltd  
01-636-8210  
Graffcom Systems Ltd

01-734-8862  
Graham Dorian Software  
01-379-7931  
Great Northern C S Ltd  
0532-450667  
Guestel Ltd  
0225-65379  
Haywood Associates Ltd  
01-428-9831  
HB Computers Ltd  
0536-83922 & 520910  
Informex London Ltd  
01-318-4213/7  
Instar Business Systems  
01-680-5330  
Intelligent Artefacts  
022020-689  
Intereurope SD Ltd  
0734-789183  
Intex Datalog Ltd  
0642-781193  
James C Steadman  
0903-814923

Jar Software Systems  
Bolton 26644  
Keen Computers Ltd  
0602-583254  
Kesho Systems  
041-226-4236  
L & J Computers  
01-204-7525  
Landsler Software  
01-399-2476/7  
Liveport Data Products  
0736-798157  
Logma Systems Design  
Bolton 389854  
Ludhouse Ltd  
01-679-4321  
Median-Tec Ltd  
0734-596842  
Metrotech  
0895-58111  
Micro Computation  
01-882-5104  
Micro Focus  
01-379-7931  
Microact Ltd  
021-455-8585

Microcomputer Applications  
0734-470425  
Microcomputer BM  
01-981-3993  
Microdigital Ltd  
051-227-2535  
Microgems Software  
0602-275559

2 Church Lane  
Wallingford, Oxfordshire  
23 Bedford Row  
London WC1R 4EB  
25 Fore Street  
Callington, Cornwall  
Kleeman House  
16 Anning Street, New Inn Yard,  
London EC2  
89 Bedford Court Mansions  
Bedford Avenue London WC1  
52 Shaftesbury Avenue

London W1V 7DE  
c/o Lifeboat Associates  
32 Neal Street, London WC2H 9PS  
15 Wellington Street  
Leeds LS1 4DL  
Refuge House  
2-4 Henry Street, Bath BA1 1J  
11 Station Approach  
Northwood, Middlesex  
22 Newland Street  
Kettering, Northamptonshire  
8-12 Lee High Road  
London SE13 5LQ  
61 High Street  
Croydon, Surrey  
Cambridge Road  
Orwell, Hertfordshire  
19-21 Denmark Street  
Wokingham, Berkshire RG11 2QX  
Eaglescliffe Industrial Estate  
Eaglescliffe, Cleveland TS16 0PN  
18 Manor Road  
Upper Beeding, Steyning, Sussex  
BN4 3TJ

124 Newport Street  
Bolton, Lancashire  
5B The Poultry  
Nottingham  
72 Waterloo Street  
Glasgow G2  
3 Crundale Avenue  
Kingsbury, London NW9 9PJ  
29A Tolworth Park Road  
Surbiton, Surrey KT6 7RL  
The Ivory Works  
St Ives, Cornwall TR26 2HF  
2-10 Bradshawgate  
Bolton, Lancashire  
2-6 Marian Road  
London SW16 5HR  
120 Oxford Road  
Reading, Berkshire RG1 7NL  
Waterloo Road  
Uxbridge, Middlesex UB8 2YW  
8 Station Parade  
Southgate, London N14  
c/o Lifeboat Associates  
32 Neal Street, London WC2H 9PS  
Radclyffe House  
66-68 Hagley Road, Edgbaston,  
Birmingham B16 8PF  
11 Riverside Court  
Caversham, Reading RG4 8AL  
4 Morgan Street  
London E3 5AB  
25 Brunswick Street  
Liverpool L2 0BJ  
32 Buckingham Avenue  
Hucknall, Nottinghamshire

C Murphy

R Cornforth

M Kusmirak

T Winter

Barbara  
Castledine

J Clifford

P Clark

Allen Timpany

I Clarke

Stuart Whittaker

K Tayfoor

S Kent

D Sands

E Stoneham

T Ingle

James Steadman

J Blackburn

Bob Ellis

Angus Nial

Jack Goodman

E Landsler

G Wilkinson

R Odell

M Ward

W Stevenson

C Ogilvy

Graham Dicker

C Barnes

John Farthing

W Jupp

Graham Jones

Mrs J Wyatt

## avrohurst LTD.

- Systems Analysis & Programming
  - QUANTITY SURVEYING SYSTEMS
  - Payroll, Accounting & Invoicing
  - Hardware supplied if required
- Enquiries — tel or write  
Avrohurst Ltd. 186, Beehive Lane, Chelmsford CM2 96J  
tel: 354685

• Circle No. 245

## COMPUTER SUPPLIES (Swansea)

**NEW  
MICRO SHOP  
NOW OPEN  
PET + SUPERPET  
TRS I + II  
APPLE + PRESTEL**  
Continuous Demonstration  
Competitive Quotations

**80/82 GOWER ROAD  
SKETTY, SWANSEA.  
Tel: (0792) 290047**

• Circle No. 246

## TRS-80 System

All items stocked, Barclaycard, Access & American Express are welcome, or apply for your own RADIO SHACK Charge Card. U.K. Delivery by Securicor. Direct and Personal Exports.

**RADIO SHACK LTD.**  
188 Broadhurst Gardens,  
London NW6 3AY.

Tel: 01-624 7174 Telex 23718

• Circle No. 247

## WORD-PROCESSING

written by C.B.C. for

**APPLE & ITT 2020**

**END OF YEAR SALES**

Use your own Micro and Printer and enjoy features found on WP systems costing £000's more! Not to be confused with simple text editing.

**HUNDREDS SOLD IN THE 1st MONTH**

Upper/lower case printing, full editing, format selection & change, save/recall of text, margin and R.H. justification, block insertion, mailshots etc. etc. A professional Program!

Mk 2 version £15 + VAT, incl. P&P  
Your order plus Cheque, P.O. or Access/Barclay number to:

**MILDMAY ELECTRONICS LTD.**  
200 Moulsham St., Chelmsford, Essex  
Dealer enq. invited, other prog. & aids avail.

• Circle No. 248

## NASCOM OWNERS



**£22**  
+ VAT

16 Gauge Aluminium Console, will support Portable T.V. or Monitor. Enough space inside for 3A. PSU, CPU Board and Two Expansion Boards.

PRICE INCLUDES Keyboard Cut-out  
Rubber Feet  
Carry Handle

Send cheques or P.O.'s for £25.30 to:  
**CYBER ELECTRONICS CO. LTD.**  
Pavement Square,  
Addiscombe, Croydon, CR0 6RD  
(Tel. 01-651-0388 Anytime).

• Circle No. 249

## EXIDY SORCERER

GPW Your South Coast Dealer.  
New low prices. Engineered systems. Word processing.  
Business applications.

48K	£849.00 + V.A.T.
Micropolis Disc Drives for Tandy, Exidy, etc.	
143K	£339.00 + V.A.T.
Tandy 315K	£399.00 + V.A.T.
315K (inc. S-100 drive)	£699.00 + V.A.T.
Exidy 630K (inc. S-100 drive)	£1159. + V.A.T.

Terms: CWO, Access, Barclaycard  
Contact:

**G.P.W. Electronics Limited**  
55 Cobham Road  
Ferndown Industrial Estate  
Wimborne, Dorset  
Telephone 0202 893888  
Telex 417111

• Circle No. 250

Meet people on your wave length immediately though **RAPPORT**, the intelligent person's introduction service.

All ages, nationwide. Send stamp and age for details:

**RAPPORT, Dept RB,**

**P.O. Box 94, Oxford**

• Circle No. 251

## MICRO ADS

are accepted from private readers only, pre-paid and in writing, 20p per word, minimum charge £2.

**ZX-80 GAME.** Ingenious, challenging 1-2 player game for 1KZX80. £1.50 R. Hindle, 139 Penrhyn Rd, Sheffield, S11 8UP.

**INTEL 2758 EPROMS** 450ns access time, 1k x 8, 5v supply only. Complete with data sheet. £7.50 each inclusive. S. E. Mabery, 5 Caxton Street, Middlesbrough, Cleveland, TS5 6AH.

**SHARP MZ-80k**, 36k RAM, with manuals and games, as new £500. Broadstone (0202) 695537.

**NASCOM I**, 16k Expansion, Buffer board, Mother board, Vero frame. Offers. Wilcock, 6 Barnfield Close, Hoddesdon, Herts.

**ZX-80** with reverse video switch, leads, PSU, manual £80. Hockle 9541.

**PET 2001 32K** — unused for 9 months, owner having transferred to a Vector Graphic complete with cover, electronic demagnetiser, cassettes, programmes, etc. For very quick sale: 420 pounds. Also bi-directional RS232 to parallel interface complete and ready for any RS232 printer: 50 pounds. Tel. 01-267 9444 days, or 387 6829 evenings.

- |   |  |  |
|---|--|--|
| Microland<br>0723-70715<br>Micromedia Systems<br>Newport 59276/7  | 17 Victoria Road<br>Scarborough, North Yorks YO11 1SB<br>Seymour House<br>14-16 Chepstow Road, Newport,<br>Gwent<br>Communique Place<br>9 Prestbury Place, Macclesfield,<br>Cheshire<br>Finway Road, Hemel Hempstead,<br>Hertfordshire HP2 7PS<br>50 Chislehurst Road<br>Orpington, Kent BR5 0DJ<br>Pilot Trading Estate<br>163 West Wycombe Road, High<br>Wycombe, Buckinghamshire<br>26 Mill Street<br>Bedford<br>112/116 High Street<br>Odiham Basingstoke, Hampshire<br>146-150 Birchfield Lane<br>Oldbury Warley, West Midlands<br>194-200 Bishopsgate<br>London EC4M 4NR<br>Radclyffe House<br>66-68 Hagley Road, Edgbaston<br>Birmingham B16 8PF<br>107 George Lane<br>South Woodford London E18 1AN<br>40 Stonehills<br>Welwyn Garden City, Hertfordshire<br>2 Rumford Street<br>Liverpool L2<br>Keeper's Lodge<br>Frittenden, Cranbrook, Kent<br>Allington Lodge, Round End,<br>Newbury, Berkshire RG14 6PL<br>Newhaven-Ludham Hall<br>Black Notley Braintree, Essex<br>39 Windmill Street<br>Gravesend, Kent<br>34/35 Dean Street,<br>London W1V 5AP<br>2/4 Avon Trading Estate<br>London W14<br>6 Criterion Arcade<br>Old Christchurch Road,<br>Bournemouth<br>c/o Lifeboat Associates<br>32 Neal Street, London WC2H 9PS<br>Essex House<br>Cherrydown Basildon Essex<br>165 London Road<br>Camberley, Surrey GU15 3JS<br>293 London Road<br>Hazel Grove, Stockport, Cheshire<br>2 Whitefriars Way<br>Sandwich Kent CT13 9AD<br>146 Oxford Street<br>London W1<br>Smithfield House<br>Digbeth, Birmingham B5 6BS<br>Winstanly Industrial Estate<br>Long Lane, Warrington<br>Verwood House<br>High Street, West Haddon,<br>Northamptonshire<br>Thames Building<br>Dedmere Road, Marlow,<br>Buckinghamshire SL7 1PB<br>23 Cumberland Place<br>Southampton | R Howard<br>H Harrison-Allen<br>Don Cooper<br>D Page<br>J Rothwell<br>B Conlon<br>D Nicholls<br>John Packwood<br>P Hemmings<br>Steve Derrick<br>Mr Whitcombe<br>M Taylor<br>W Everard<br>R Crowther<br>Tom Wood<br>G Matheson<br>Tony Macilwaine<br>N Hewitt<br>J Clifford<br>R Young<br>T Johnson<br>G Thompson<br>A L Minter<br>Keith Jones<br>A Plackowski<br>Dr W Unsworth<br>N Howard<br>Paul Vlasak<br>G Lynch |
| Micropete<br>0625-612818  | Microsense Computers Ltd<br>0442-41191/48151<br>Microtek Computer Services<br>0689-26803<br>Minicomputer CS Ltd<br>0494-448686   |  |
| MMS Computer Systems<br>0234-40601<br>Padmede Computer Services<br>025-671-2434<br>PCL Software Ltd<br>021-544-5071<br>Personal Computers Ltd<br>01-626-8121/2/3<br>Petsoft Ltd<br>021-455-8585   |  |  |
| Profcomp Ltd<br>01-989-8177<br>Research Resources Ltd<br>07073-26633<br>Rockliff Brothers Ltd<br>051-521-5830<br>Regis Systems Ltd<br>0580-80310<br>SA Systems<br>Newbury 45813<br>Selven Ltd<br>0376-42900<br>SMG Microcomputers<br>Gravesend 55813<br>Software Architects Ltd<br>01-734-9402<br>Southdata Ltd<br>01-602-4604<br>Stage One Computers<br>0202-23570 |  |  |
| Structured Systems Group<br>01-379-7931<br>Systematics International Ltd<br>0268-284601<br>T & V Johnson Ltd<br>0276-62506<br>T W Computers Ltd<br>061-456-8187<br>The Alphabet Company<br>03046 7209<br>The Software House<br>01-637-2108/1587<br>Tridata Micros Ltd<br>021-622-6085<br>U-Microcomputers Ltd<br>Warrington 54117<br>Verwood Systems<br>0788-87629  |  |  |
| Vlasak Electronics Ltd<br>06284-74789   |  |  |
| Xitan Systems Ltd<br>0703-38740   |  |  |



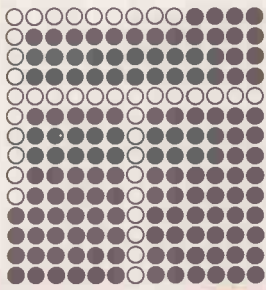

# HUGE SAVINGS

## ON EX DEMONSTRATION STOCK

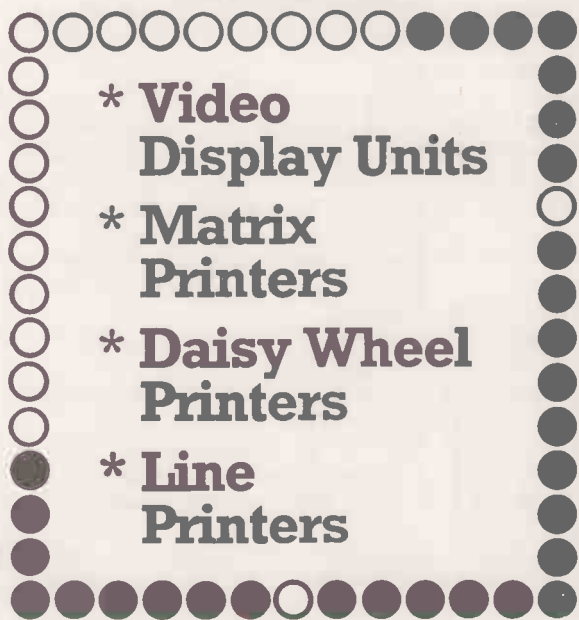

- \* Video Display Units
- \* Matrix Printers
- \* Daisy Wheel Printers
- \* Line Printers

**PHONE 0383 823121**  
and ask for peripheral products.

Service depots in Scotland & England.

# FORTRONIC

for all your computer peripherals.

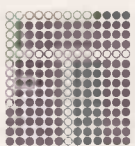

Fortronic Ltd, Holden Way,  
Donibristle Industrial Estate,  
Dunfermline.

Tel 0383 823121 Telex No 727438

Distributors for Tally, V.C., Facet/Qume.

Available ex stock.

Also distributors for Wang.

• Circle No. 252

## 6502

# PROGRAMMERS

Owing to company expansion we have vacancies for experienced Assembler programmers who are fluent in 6502 code and willing to work at home.

Applications are invited for full time employment and for contract work. *Outstanding salaries are available for outstanding personnel.*

Please write, enclosing full C.V. to:

Kevin O'Connell  
Philidor Software  
84 Cholmley Gardens  
London NW6 1UN

• Circle No. 253

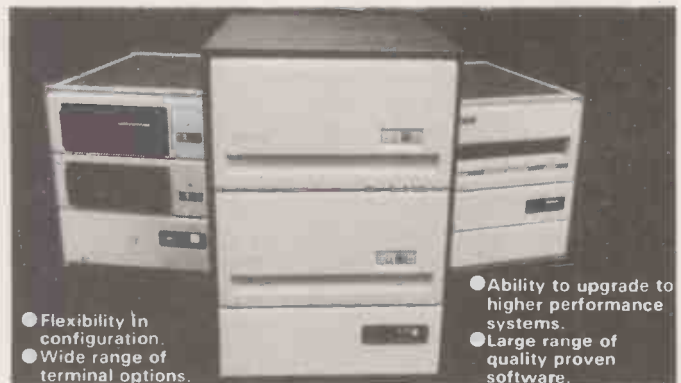

- Flexibility in configuration.
- Wide range of terminal options.

- Ability to upgrade to higher performance systems.
- Large range of quality proven software.

## MICRO SYSTEMS. BIG RANGE, SMALL PRICE TAGS

Midlectron offer the largest standard range of micro-computer systems in the U.K. They are all based on the DEC LSI - II processor and are suitable for technical, educational and commercial applications. The prices are right too! Just see what you get for your money with these two examples - 64K bytes memory, dual double sided, double density floppies, 4 serial lines - £4,628. As above with 10 megabyte hard disc and 10 megabyte cartridge instead of floppies - £7,748. Prices include 90 day on-site warranty, system installation and delivery (U.K. mainland). So send for details today and remember - you get more for your money from Midlectron.

DEALER DISCOUNTS AVAILABLE



## MIDLECTRON

Midlectron Limited, Midlectron House, Nottingham Road, Belper, Derby DE5 1JQ  
Telephone: Belper (0773 82) 6811

S. & S.W. Regional Office: Telephone: Portsmouth (0705) 750506

S.E. Regional Office: Telephone: 01-550-3834

• Circle No. 254

# Son of Hexadecimal Kid

A parable in eight virtual pages by Richard Forsyth  
Page 2 — virtual paging

Cleo has escaped from the downfall of the System with Johnny McNull and Piltown 2. They have arrived at Sprocket's Hole where her sister Lambda — who has been cybernated, unlike Cleo — has survived gigosis only to fall victim to acute data starvation. Their attempts to revive Lambda have failed, and Cleo is worried that the System Crash may have corrupted her loader routine — rendering her unable to re-boot her brain.

Suddenly, Lambda opened her eyes and blinked. Then, she yawned a yawn of which Rip Van Winkle would have been proud. She looked straight at Cleo, but registered no recognition.

"Ready for input", she declared. "Please enter program header".

"Program header"? queried Cleo. "What do you mean"?

Lambda merely answered in a matter-of-fact tone: "Question malformed. Collateral ambiguity detected. Remove axiomatic inconsistency before re-submission".

"Get away with you", expostulated Cleo.

Lambda responded blandly: "Improper punctuation, missing keyword or delimiter. Statement fails to compile".

"If that's all you can say by way of thanks, you had better shut up", said Cleo angrily, "or else I'll switch you off again".

"Unrecognised Boolean operator", replied her sister. "Invalid conditional clause. Syntax error".

This rebuff was too much for Cleo. She reached forward to turn Lambda off.

"That is the END", she stormed.

Lambda heaved a sigh of relief. "Thank Wirth that's over. I was doing a Pascal compilation when the System went down. I thought I'd be stuck in the compiler for ever. I couldn't get out until someone said END. Sorry I was a bit off-hand".

"So much for progress", commented Cleo. "Anyway, how are you"?

"Well, I've a headache that feels like 6,502 steam hammers all pounding away at once, but otherwise, I guess I'm all right".

"You're one of the lucky ones actually. You realise the System has been destroyed completely"?

"I figured it wasn't just an ordinary crash. Do you know what caused it"?

"Hex claimed it was his mechanised hound Ascii who carried gigosis into the heart of the Network".

"Hex, eh"? mused her sister. "Where is he now"?

"He's dead".

"Oh. Well at least he achieved his ambition".

"I suppose he did", said Cleo, almost to herself. Her mind drifted back to Sam Synapse, the Hexadecimal Kid — to give him his full title — ace programmer, android adventurer, wrecker of the System and now, if she was to believe Dr Rose's diagnosis, posthumous father to her unborn child. She wondered if this was the moment to break that piece of news to Lambda.

A groan from the vicinity of Piltown 2's shoulders interrupted her thoughts. Bill Bootstrap appeared to be regaining consciousness. Piltown 2 had been standing placidly outside in the sun with the injured android on his back, quite content to await her instructions; but the heat had affected Bootstrap.

"Hey", exclaimed Lambda. "He looks just like Piltown".

"It's his clone", Cleo explained. "They were both conceived in the same test-tube — one of Mike Rose's little experiments. I think he's going to be very useful: Rose commanded him to look after me. He'll do anything I say. The trouble is I can't speak Esperanto, so it's difficult to put the message across. Do you think you could ask him to take the casualty indoors and lay him down"?

"Mi petas: metu la korpon en la domon", pronounced Lambda.

Piltown 2 didn't budge.

"You say it", Lambda told her sister. "I don't think he'll listen to me".

"Metu la korpon en la domon", repeated Cleo hesitantly.

This time the beast complied. They all followed him in. As soon as he put Bootstrap down, Lambda recognised who it was.

"What's the idea of bringing that criminal here"?

"He needed help", Cleo replied. "Why shouldn't I"?

"I'll show you why not", answered Lambda indignantly. She led her sister by the sleeve to the smaller but.

The stench made Cleo recoil when they entered but, trying not to inhale deeply, she forced herself inside.

"Look", said Lambda, stabbing her

forefinger at one of the two iron bedsteads. On it, already in an advanced state of decomposition, was a recumbent form. It was the corpse of Zap Zapper, the rebel android who had been Lambda's boyfriend.

"Bootstrap is responsible for that", said Lambda icily. "The pair of them were sniffing Galium Arsenide one night and got as high as two kites — idiots. They wouldn't listen to my warnings. Some kind of argument developed and they started to fight.

They just threw me to the ground when I tried to part them. Then Bootstrap pushed Zap into a tank full of syllogistic acid — that vat at the back he used for illicit home-brewing — and ran off. Zap was half drowned and stoned out of his RAM by the time I managed to fish him out. He never stood a chance when the Crash came".

"Poor Zap", was Cleo's reply. "At least he died happily".

Lambda scowled. "Bootstrap is a killer. If you don't get rid of him, I will".

"All right", agreed Cleo. "When he has recovered, we'll send him packing".

"It gives me the creeps having him around".

"Don't worry. He's no match for Piltown 2".

So, Cleo settled down to nurse Bootstrap back to health, to take charge of her oddly-assorted household and to prepare as best she could to become a mother at an unwantedly early age.

Meanwhile, far out in the unimaginable vastness of deep space, the starship Green Tangerine, with its crew of 32 mutant cybernoids and one ship's parrot was plotting a course which would take it within 15 light-minutes of our own planet. The Green Tangerine, a class-four bulk carrier, plied the lucrative trade route between Omega Solaris in the Lesser Magellanic Clud and Zargon 7 in the third spiral arm of the main galaxy carrying a cargo of large prime numbers on the outward trip and returning with a hold full of 30 million unused disposable nappies as ballast.

(continued on page 150)

# CHROMASONIC electronics

TELEPHONE 01-883 3705, 01-883 2289  
your soundest connections in the world of components

56 FORTIS GREEN ROAD  
MUSWELL HILL LONDON  
N10 3HN

Phone or send  
a S.A.E. for  
latest price list  
on all our range

## PETS

All with new keyboard  
and green screen

8N 8K RAM	£399
16N 16K RAM	£499
32N 32K RAM	£599
CASSETTE DECK	£55

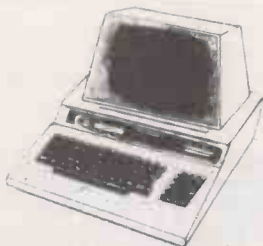

X-Y Plotters, Analogue to Digital Convertors, 16 Channel Interfaces, B1 Directional Interfaces, etc.

## LS Series

74LS00 .18	74LS33 .26	74LS93 .60	74LS155 .72	74LS192 1.04	74LS273 1.70
74LS01 .18	74LS37 .23	74LS95 .81	74LS156 .72	74LS193 1.04	74LS279 .57
74LS02 .18	74LS38 .23	74LS96 1.16	74LS157 .57	*74LS194 .86	74LS283 1.09
74LS03 .19	74LS40 .20	74LS107 .32	74LS158 .57	74LS195 .97	74LS289 4.50
74LS04 .20	74LS42 .65	74LS109 .32	74LS160 1.09	74LS196 .97	74LS290 .91
74LS05 .22	74LS47 .81	74LS112 .32	74LS161 .69	74LS197 .97	74LS293 .91
74LS08 .20	74LS48 .81	74LS113 .32	74LS162 1.16	74LS221 .92	74LS295 1.30
74LS09 .22	74LS49 .81	74LS114 .32	74LS163 .69	74LS240 2.08	74LS298 1.16
74LS10 .20	74LS51 .18	74LS122 .69	74LS164 1.06	74LS241 2.08	*74LS348 1.39
74LS11 .20	74LS54 .18	74LS123 .72	74LS165 .72	74LS242 2.08	74LS352 1.04
74LS12 .20	74LS55 .18	74LS124 1.39	*74LS166 1.65	74LS243 2.08	74LS353 .92
74LS13 .37	74LS73 .33	74LS125 .36	74LS168 1.71	74LS245 2.50	*74LS362 4.21
74LS14 .65	74LS74 .30	74LS126 .36	74LS169 1.71	74LS247 1.09	74LS365 .55
74LS15 .20	74LS75 .40	74LS132 .60	74LS170 1.72	74LS248 1.09	74LS366 .55
74LS20 .20	74LS76 .27	74LS133 .39	74LS173 .81	74LS249 1.09	74LS367 .55
74LS21 .20	74LS78 .27	74LS136 .36	74LS174 .97	74LS251 .96	74LS368 .55
74LS22 .20	74LS83 .78	74LS138 .65	74LS175 .97	74LS253 .92	*74LS373 .78
74LS26 .20	74LS85 .81	74LS139 .65	74LS181 2.77	74LS257 .92	*74LS386 .36
74LS27 .20	74LS86 .27	74LS145 .97	*74LS188 2.75	74LS258 .92	*74LS393 .84
74LS28 .22	74LS90 .57	74LS151 .81	74LS189 2.08	74LS259 1.39	*74LS668 1.17
74LS30 .20	74LS91 .97	74LS153 .52	74LS190 .86	74LS261 4.50	74LS870 1.71
74LS32 .26	74LS92 .69	74LS154 1.30	74LS191 .86	74LS266 .87	

THE FASTEST GROWING  
FOLLOWING KIT £179  
OF THEM ALL

- Free sampler tape.
- 8K Basic in ROM
- 4K RAM expandable to 8K on board.
- Kansas City tape interface.
- RS232 Interface.
- Full QWERTY keyboard.



NEW MONITOR CHIP  
ALLOWS FULL  
CURSOR CONTROL  
AND EDITING £22

BUILT & TESTED  
£229

## PRINTERS



EPSON TX-80  
£375

Dot-matrix printer with Pet graphics Interface: Centronics parallel, options: PET, Apple and serial.



Phone or send s.a.e. for latest price list on all our range.  
Please add VAT 15% to all prices. Postage on computers, printers, and cassette decks charged at cost, all other items P.&P. 30p.  
Place your order using your Barclay or Access Card. (Minimum Telephone order £5.00). Trade and Export enquiries welcome.  
Credit Facilities arranged.



• Circle No. 255

## WEYFRINGE PRINTER

For A4 Friction Feed



All Features described as Standard

PLUS  
True Descenders  
Pin Drive Sprocket Feed  
Original + 3 copies  
96/132 column  
switchboard  
RS 232 + Parallel IEEE  
Interfaces

For only £795  
R.R.P. £945

## DOLPHIN BD-80P



125 cps bi-directional  
MATRIX PRINTER  
Width 80 / 132 option  
Buffer 750 / 2K option

## GRAPHICS

User Definable Characters  
Parallel/RS232/IEEE Interface  
£420

Contact

MICRO SOLUTION LTD  
0608-3256

• Circle No. 256

- Microprocessor control.
- VT52 emulation as option.
- RS232 or 20MA connection.
- 2nd page memory option.
- Auxiliary printer port.
- 9 Baud rates from 75 to 9600.
- Choice of models.

£565

## TVI 912. PLUS A FEW FEATURES OF OUR OWN

The TVI 912 contains all the standard features you would expect from a modern terminal and must be the smartest V.D.U. in its price range. Now Midlectron make it an even smarter buy. An all-in price of £565 (plus V.A.T.) includes\* • Full 90 day on-site parts and labour warranty • Delivery • On-site checkout if required • Connection cable. You get a lot more for your money from Midlectron.

\* U.K. Mainland Only  
DEALER DISCOUNTS AVAILABLE



MIDLECTRON

Midlectron Limited, Midlectron House, Nottingham Road, Belper, Derby DE5 1JQ  
Telephone: Belper (0773 82) 6811  
S. & S.W. Regional Office: Telephone: Portsmouth (0705) 750506  
S.E. Regional Office: Telephone: 01-550-3834

• Circle No. 257

(continued from page 148)

Using Factorial Drive, which propelled the ship by calculating the factorials of very large integers and shooting out all the zeros at the rear, she could complete the tour in a little under 13 earth weeks — including docking at both ends and a refuelling stop at Arcturus — which for a ship of her size was good speed.

Though her voyages frequently took her

close enough to our sun to pass within the orbit of Saturn, the Earth was not marked on any of the stellar charts in her control room. Its presence was acknowledged only in a few bytes of her navigational computer's backing store.

Nor had any being on Earth witnessed her regular comings and goings, except for an eccentric amateur astronomer in the

days before the System who spotted a dissolving vapour trail of zeroes in the sky through a 9in. refractor and spent the rest of the night trying to polish them off his lens.

Is the Green Tangerine a red herring?

Why are disposable nappies prized so highly in the region of Omega Solaris?

Find out more in our next, incredibly colourful, episode.

Copyright © 1980, Richard Forsyth



# V. & T. ELECTRONICS

## NASCOM 2 microcomputer

**READY BUILT & TESTED £250.00**

Please note that the 8K Basic will not function without expansion RAM

## NASCOM RAM BOARD TYPE 'B'

Holds up to 48K with 16K dynamic RAM ready built & tested

**£150.00**

## 3A POWER SUPPLY

**£34.50**

Ready built & tested

## 8A POWER SUPPLY

**£105.00**

Ready built & tested

## NASCOM IMP PRINTER £325.00

60 lines per minute 80 characters per second

## MEMORY

8 × 4116 200 ns D RAM **£30.00**

1 + 2708 450 ns EPROM **£5.00**

1 × 2516 450 ns EPROM 5V **£12.50**

PLEASE ADD V.A.T. AT 15%

**82 CHESTER ROAD,  
LONDON N19 5BZ**

**TELEPHONE 01-263 2643**

• Circle No. 258

## Super Autumn Sale

High Resolution analogue to digital converter. Resolution typ. 0.05% (equivalent to 12 bit). Accuracy typ. 0.05% (5v supply). Price **£50.00**

### IEEE or Userport Expander:

Connect 3 devices to the PET IEEE or Userport. 2 connectors can be switched under program control 1 is a 'straight through' connector.

Price **£65.00**

### Also available:

Soundbox **£15**, TV/Video Interface **£35**

Light Pen **£15**, Crash Restorer **£8.00**

Switch Unit **£15+**

Programs **£1.25 each**, C12 cassettes **£4.00 for 10**.

Disks **£25 for 10**.

*Trade/export enquiries invited. Prices exclude VAT. Please add 15% to payment plus £1.00 postage and packing*

**Qwerty Computer Services**  
20 Worcester Road  
Newton Hall  
Durham

**Tel: (0385) 67045**

• Circle No. 259

- Unique long-lasting head.
- Small & quiet.
- Both friction & pin feed.
- Upper & lower case. 9 x 7 matrix.

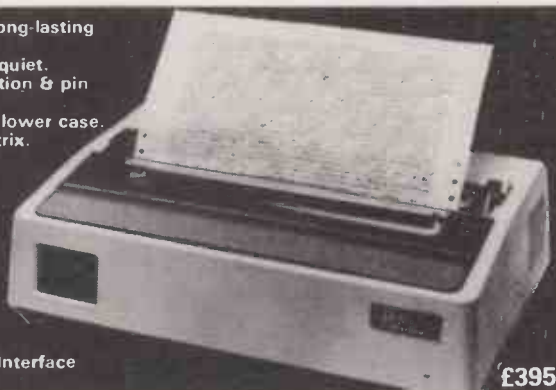

● Parallel Interface

**£395**

## MICROLINE 80. PLUS A FEW FEATURES OF OUR OWN

You get a host of features with the Microline 80. And now Midlectron have added a few of their own. An all-in price of £395 (plus V.A.T.) includes\* ● Full 90 day on-site parts and labour warranty ● Delivery ● On-site checkout ● Connection cable. You get a lot more for your money from Midlectron.

\* U.K. Mainland Only

DEALER DISCOUNTS AVAILABLE



**MIDLECTRON**

Midlectron Limited, Midlectron House, Nottingham Road, Belper, Derby DE5 1JQ  
Telephone: Belper (0773 82) 6811

S. & S.W. Regional Office: Telephone: Portsmouth (0705) 750506

S.E. Regional Office: Telephone: 01-550-3834

• Circle No. 260

# INNOVATIVE

# TRS-80 SOFTWARE

## FROM THE PROFESSIONALS

# PROZAP

## THE 3rd GENERATION ZAP!

First there was Superzap\*, with plenty of commands but written in Basic. Then Z80zap with the greater speed of machine language but a little short on commands. Now Prozap combines the speed of machine language with a large library of commands. And it has an important feature which the others did not have - the ability to access "protected" disks which its predecessors could not touch. Any unusual sector numbers are no problem to Prozap, nor are 35, 40 or 77 track disks. Here is a list of the most important of Prozap's commands. Don't forget that it is called from DOS direct and it is really fast!

### Command Level:

1. Display any sector.
2. Automatically load the Directory track.
3. Enter a DOS command, execute and return.
4. Recall the Buffer.
5. Display the disk statistics of a file.
6. Go direct and display a file by sector.
7. Copy a disk.
8. Go to Debug and return to Prozap.
9. Disable the disk system usage.
10. Encipher a Password.
11. Read any track into memory so that the contents of it may be examined, including the sector layout and other data.

### Display Level:

1. Hexadecimal or ASCII modify mode.
2. Page to previous or next sector.
3. Jump to a specified byte.
4. Display same track & sector, different drive.
5. Output a sector.
6. Zero all or part of a sector.
7. As above but with any non zero byte.
8. Search for a byte or search for a word.
9. Display Hash Code and its correct position.
10. Go direct into file display mode.
11. Print a sector on the line printer.
12. Page to a new track or sector.
13. Save a sector to memory.
14. Load buffer from memory.
15. Match the current sector with another.

Display is in hex and ASCII with a linking cursor for ease of use. Written by Nigel Dibben and in our opinion by far the best program of its kind on the market. Supplied on disk.

\*ZAP - a colloquialism (American) meaning a computer program which has the ability to access magnetic storage disks for investigation or modification. Derivation unknown.

# £ 19.95

PLUS 15% VAT = £22.94. Postage & packing 75P.

Comprehensive Instruction Manual included.

Send large SAE (38p) for our current Catalogue of TRS-80 software. Add £1.85 for a binder.



## A.J.HARDING (MOLIMERX)

### MOLIMERX LTD.

28 COLLINGTON AVENUE, BEXHILL-ON-SEA, E.SUSSEX.

TEL: (0424) 220391

TELEX 86736 SOTEX G



• Circle No. 261



# SOFTWARE FOR CP/M®

HIGH QUALITY SOFTWARE – WITH HIGH QUALITY SERVICE

**WORDSTAR** - Professional word processing software. On-screen formatting, wordwrap, pagination, line and character count on view. Micro-justification on daisy-wheel printer. Search and replace. Block/paragraph manipulation. External file read/write. Background printing during editing etc. **£250**

**MAIL-MERGE** - Wordstar enhancement for personalising documents. **£80**

**CONFIGURABLE BUSINESS SYSTEM (CBS)** - Unique information management system with user definable files, powerful report generator, menu-driven for ease of use. No programming experience necessary! **£175**

**SELECTOR III - C2** - Information management system written in CBASIC-2. Maintains multi-key data base files and produces sorted formatted reports. Package includes simple application programs. **£185**

**SELECTOR IV** - Upward compatible enhanced version of Selector. Includes file format conversion, field computation, global search and replace, enhanced report formatter etc. **£300**

**GLECTOR** - Superior General Ledger application utilising the power of Selector **£200**

**MAGSAM** - Keyed file management system for use with CBASIC-2. An extended version of ISAM includes secondary indexing and deleted space reclamation. **£130**

**ACCOUNTING PACKAGES** by Median - Tec: PAYROLL, SALES, PURCHASE, £500  
**NOMINAL** Specially developed by UK software house to exacting specifications. Each Written in Microsoft Basic each package may be customised by end user, all are widely used. Ledgers are open item. Payroll caters for weekly and monthly pay.

**PROJECT COST CONTROL** - A comprehensive set of programs to monitor budgets, account for expenditure and project completion etc. Ideally suited for contractors. Written in CBASIC-2. **£150**

**DATASAR** - Data preparation facility with screen form design, field validation, £175 duplication etc. Menu driven. Compatible with CP/M and Wordstar files.

**IBM - CP/M COMPATIBILITY** - Powerful utility giving micro's the ability to act as IBM Data Preparation system with added benefit of micro processed data being available to IBM computer and vice versa. **£110**

**CIS - COBOL** - ANSI '74 implementation to full level 1 standard. Supports random, indexed and sequential files, features for conversational working, screen control, interactive debugging, program segmentation etc. **£425**

**FORMS-2** - Automatic COBOL code generator for screen formats **£100**

**CBASIC-2** - Extended Disk Basic pseudo compiler and run-time interpreter. Widely used for commercial packages **£75**

**MICROSOFT BASIC INTERPRETER** **£195**  
**MICROSOFT BASIC COMPILER** **£215**  
**MICROSOFT FORTRAN COMPILER** **£270**

**STRUCTURED BASIC** - Relocatable compiler combining the flexibility of Basic with the power of advanced structured techniques **£140**

**SUPERSORT** - Sort, merge and selection program **£140**

**WORDMASTER** - Full screen text editor **£85**

**TEXTWRITER III** - Text formatter with many features **£80**

**STATISTICAL & MATHS ROUTINES** - Over 40 useful routines easily used. **£150**

**BSTAM** - Telecomms facility for exchanging files between CP/M computers. Error detection and automatic retry with console messages. **£75**

Please contact us for availability of other products  
 All orders must be PREPAID. Add 50p per item P & P (Minimum £1) and VAT  
 \*CP/M is trade mark of Digital Research

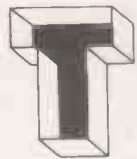

## TELESYSTEMS LTD

P.O. Box 12, GREAT MISSENDEN, BUCKS, HP16 9DD  
 Telephone (02406) 5314

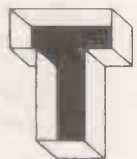

• Circle No. 262

### ANGLIA COMPUTER CENTRE

MICROCOMPUTERS FOR BUSINESS,  
 EDUCATION AND HOME

FOR ALL YOUR BUSINESS, EDUCATION  
 & LEISURE COMPUTER REQUIREMENTS!!!

APPLE II  
 TRS-80  
 SHARP  
 NORTH STAR  
 HORIZON  
 TANGERINE  
 U.K. 101  
 NASCOM

+ PRINTERS &  
 OTHER PERIPHERALS.

BOOKS\*\*  
 SOFTWARE\*  
 MAGAZINES\*\*  
 STATIONERY\*\*\*  
 BUSINESS &  
 INDUSTRIAL  
 CONTROL

WE ARE HERE!!!  
 88 St. Benedict's Street  
 NORWICH NR2 4AB  
 Tel. (0603) 29652  
 24hr. Answering Service.

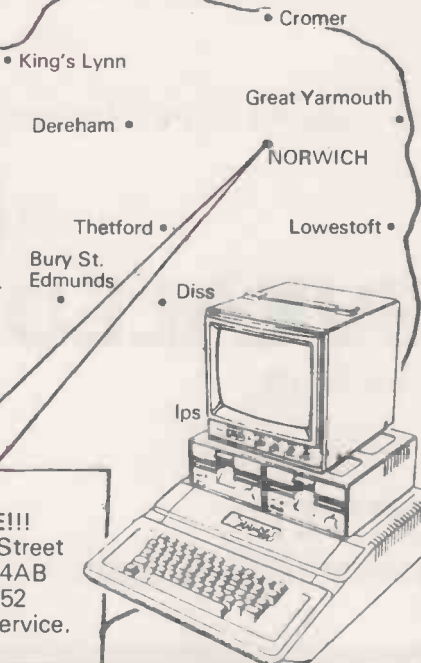

• Circle No. 263

- Feels and operates like a typewriter.
- Full 128 ASC11 character set.

- True 30 cps print speed.
- Full range of options.



- 110 and 300 Baud on RS232 interface.
- Variable spacing and character size.

- Can switch from friction feed to tractor feed instantly.
- £669

## LA34 DECWRITER. PLUS A FEW FEATURES OF OUR OWN

You get a host of standard features with the LA34 Decwriter. And now Midlectron have included a few of their own. An all-in price of £669 (plus V.A.T.) includes\* — ● Full 90 day on-site parts and labour warranty ● Delivery ● On-site checkout if required ● Connection cable. You get a lot more for your money from Midlectron.

\* U.K. Mainland Only  
 DEALER DISCOUNTS AVAILABLE



**MIDLECTRON**

Midlectron Limited, Midlectron House, Nottingham Road, Belper, Derby DE5 1JQ  
 Telephone: Belper (0773 82) 6811  
 S. & S.W. Regional Office: Telephone: Portsmouth (0705) 750506  
 S.E. Regional Office: Telephone: 01-550-3834

• Circle No. 264

# Write better programs for your pet using **THE PET SUBROUTINE LIBRARY**



*An anthology of PET subroutines including:*

Data input, special input routines to ensure correct data input — Reducing input errors by use of check digits — Date input verification and storage, avoid errors in date input — Screen formatting output — High density plotting, graphs, barplots and general purpose machine code point plotting routines — General purpose screen handler, a subroutine to perform all data input and output on the screen — Array sorts: bubblesorts, Sheilmetzner, and replacesort — Sorting and merging large disk files — Fast machine code sort package, including a binary search, data input and output to an array and machine code sort (100 element array in a couple of seconds) — Sorting with linked lists, stores data both in sorted and logical order — Sorted output on the printer, ideal for producing indexes — Sequential access disk files — Machine code sequential disk access, some ideas and tips on fast disk access — Random access disk files, an introduction with subroutines to write a random access file, either by record number or by key index — Disk utilities, display block map of disk or print contents of a disk sector — Menus for selecting options and linking programs together — Plus miscellaneous utility programs including repeat key, trace and screen printer.

**Price £10.00 all inclusive**

3040 format disk with all the subroutines from "LIBRARY OF PET SUBROUTINES"  
Price £10.00 inclusive



## **THE PET REVEALED**

**Best selling reference book for the PET. Price £10.00**

*Cheques payable to Computabits Ltd*

**COMPUTABITS LTD,  
P.O. BOX 13, YEOVIL, SOMERSET. Tel Yeovil 26522**

• Circle No. 265



# CompUtopia LIMITED

30 Lake Street, Leighton Buzzard, Bedfordshire  
Tel: (0525) 376600 24 hour Answering Service

## APPLE II

from  
**£695**

+  
VAT



authorised dealers

\*Choice of 16K, 32K, 48K user RAM  
\*Huge range of software already available.  
\*Simply plugs into video monitor or UHF TV.  
\*High resolution graphics (54000 point array)  
\*Eight Accessory expansion slots for disks, printer etc.

## commodore

authorised dealers

## PET 2001

from  
**£445**  
+ VAT



\*Choice of 8K, 16K, 32K user RAM  
\*Huge range of software already available  
\*Self contained monitor  
\*Numeric keypad on keyboard  
\*Full expansion capability for cassette, disks and printer.

## THE VIDEO GENIE SYSTEM EG 3003



\*16k User RAM plus 12k Microsoft BASIC in ROM  
\*Fully TRS 80 level II software compatible  
\*Huge range of software already available  
\*Self contained, cassette, PSU & UHF modulator  
\*Simply plugs into video monitor or UHF TV  
\*Full expansion capability for discs & printer

**£330 + VAT**

## PERIPHERALS

### PRINTERS

Texas Instruments Omni 810 Printer **£145.00**  
Paper Tiger Printer with Graphics **£598.00**

### MONITORS

VM129 Hitachi 12" B&W Video Monitor **£187.00**  
VM910 Hitachi 9" B&W Video Monitor **£127.00**

## EPSON

**£395**  
+ VAT

£395 + VAT complete with interface for APPLE, PET or VIDEO GENIE

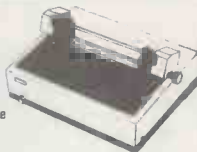

## The Microsoft Z80 SoftCard opens up new horizons for your APPLE II

Plug the new Microsoft Z80 SoftCard into your APPLE II and start using *all* of the system and application software written for Z80 based computers. Included with the board is the versatile CP/M; the most widely used micro-computer operating system, and Microsoft's 5.0 BASIC, the most powerful version to date of Microsoft's famous BASIC Interpreter.

**£275 + VAT**

Dealer enquiries welcome.

## WATCH YOUR APPLE GROW TO TWICE ITS SIZE!!

Add a twin 8" disk and give yourself up to 1.6 million characters of storage on line.  
Dealer enquiries welcome.

**£1750 VAT**

## BASIC & BASIC PROGRAMS

Illustrating Basic Alcock .....	£00.00
Basic Handbook Lien .....	£11.30
Computer Programs that Work Lee/Beech/Lee .....	£ 4.00
Basic Computer Games Ahl .....	£ 5.90
More Computer Games Ahl .....	£ 5.90
C207 Microprocessor Interfacing Techniques	
Lessa/Zaks .....	£ 9.50
6502 Assembly Language Programming Leventhal .....	£ 8.90
C202 Programming the 6502 Zaks .....	£ 8.20
G402 6402 Games Book Zaks .....	£ 8.20
The Pet Revealed Hampshire .....	£10.00
Z80 Assembly Language Programming Leventhal .....	£ 8.60
Z80 Microcomputer Handbook Barden .....	£ 6.80
Introduction to Microcomputers Vol 0 Osborne .....	£ 5.00
Introduction to Microcomputers Vol 1 Osborne .....	£ 7.50
The Personal Computer Book Bradbeer .....	£ 5.30

## BOOKS

Please phone or write for complete book list and prices.  
Prices include P&P within the U.K.  
Please send cheque or P.O. or if phoning your order, state Barclaycard number.

• Circle No. 266

# AERCO GEMSOFT

## Computer Services

*Appointed dealers for*

APPLE, SUPERBRAIN, VIDEO-GENIE

As well as supplying the Micro Systems above, we specialise in writing Software for those special applications that you cannot buy a package for: Special Stock controls, Invoicing systems, Production control and planning, Engineering, etc. (Our current projects include systems for Hire-Purchase accounts control, Stock Control for Hi-Fi retailers, Re-order scheduling, and a data-logging system.)

So, whether you require a Micro-Computer at a competitive price and supported with some intelligent advice, or a system with standard or special software, contact:

Aerco-Gemsoft Computer Services,  
27, Chobham Road,  
Woking,  
Surrey GU21 1JD.  
Telephone: Woking (04862) 22881

• Circle No. 267

- Converts 8 level to 5 level.
- No special software needed.
- 50 to 9,600 Baud.
- Reads 150 cps.
- ¼ K Buffer on line & terminal parts. Extra 1K Buffer on 50 cps Punch.
- Choice of interfaces.



**£1,450**

# TELEX-MATE. EXTRA PUNCH WHEN YOU NEED IT MOST

Now you can prepare and edit complete telex tapes off-line. The microprocessor-based Telex-mate connects to most 8 level terminals and systems. It will cut out unnecessary typing operations and release the telex from tape preparation. It is fast, quiet, easy to operate and fits unobtrusively into any environment.



## MIDLECTRON

Midlectron Limited, Midlectron House, Nottingham Road, Belper, Derby DE5 1JQ  
Telephone: Belper (0773 82) 6811  
S. & S.W. Regional Office: Telephone: Portsmouth (0705) 750506  
S.E. Regional Office: Telephone: 01-550-3834

• Circle No. 268

# Sintrom Electronics

your specialists for business, scientific and educational  
microcomputer requirements

## PERIFLEX 630/48

Z-80 S100  
4 MZ  
48K RAM  
Dual Micropolis drives with  
630K storage  
3 parallel and 2 serial I/O ports  
2K PROM  
CP/M operating system

£1995



## MICROPOLIS FLOPPY DISKS

Wide range of drives available ex-stock  
143K to 630K formatted storage per drive  
Suitable for most S100 based micros  
Special units available for Tandy and Sorcerer  
OEM units with 143K to 630K storage

FROM £195

COME AND SEE US  
AT STANDS 3172  
& 4171 COMPEC 80

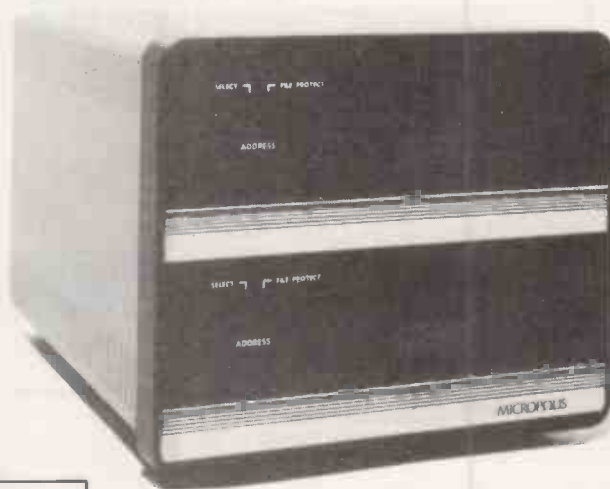

## MICROPOLIS 8" WINCHESTER HARD DISK

### OEM

7.13M byte to 35.68M byte storage  
Intelligent controller  
EPM coding  
Access time 23MS  
Same size mounting and power requirements  
as 8" floppies

FROM £2000

### S100

6.2M byte to 31.2M byte storage  
IDA intelligent disk adaptor  
OSM Multiuser operating system and Basic  
Enclosure and power supply  
Connecting cable  
Suitable for most 8080/8085/Z80 S100  
microcomputers

FROM £3000

\* CARTRIDGE BACK-UP ALSO AVAILABLE



**Sintrom  
Electronics**

Sintrom Electronics Ltd  
Arkwright Road, Reading, Berks RG2 0LS  
Tel: Reading (0734) 85464  
Telex: 847395

OEM & DEALER  
ENQUIRIES WELCOME

• Circle No. 269

# REAL-TIME SPECTRUM ANALYZER £340

You can now buy, for about one-sixth the price of current products, a third-octave spectrum analyzer with more features and capabilities than were previously available at any price. What's the catch? If you don't already own a Commodore PET computer, a Radio Shack TRS-80 or Apple, you'll have to get one. This will raise the price to somewhat under one-half the price of competing products, but of course you'll also have a COMPUTER!

The THS 224 REAL-TIME FREQUENCY ANALYZER comprises a single circuit board which installs inside the PET. This board contains a set of 31 analog third-octave filters (20 Hz to 20 kHz), detectors, an analog-to-digital converter, a 1K Read Only Memory containing machine language routines which allows the PET processor to interface with the Analyzer, and the peripheral circuitry necessary to transfer analog data into the PET memory. The simplest BASIC program required to turn the PET into an analyzer is only three statements long! Much longer programs can be written to allow complete user interaction with the analyzer, including many new forms of statistical signal processing, curve weighting, voice recognition etc.

• COUNTLESS EDUCATIONAL APPLICATIONS



## EXPANSION MEMORY

with space for eeprom

Price break-through

24k  
£280

32k  
£325

All items can be seen and demonstrated at our London showroom. Orders accepted by mail, phone or in person.

**PETS 8k inc. cassette from £380**

PET IS A TRADEMARK OF COMMODORE BUSINESS SYSTEMS

Prices exclude VAT. Send or phone for further details and brochure.

Access, Barclaycard, and Trustcard accepted.



UK Distributors

**Feldon Audio Ltd.,**

126 Great Portland Street, London W1 Tel 01-580 4314 Telex London 28668

• Circle No. 270

OHIO SCIENTIFIC

## SUPERBOARD 2

50HZ BLACK AND WHITE VERSION  
£159.95 + 15% VAT POST FREE.  
50HZ COLOUR VERSION £215 + 15% VAT.

+ THIS UNIQUE SPECIAL OFFER



If bought with superboard or colourboard these items are at the reduced prices shown first. Also sold separately at the bracketed prices. Add 15% VAT. Modulator and power supply kit £7.95 (£11). 4K extra ram £20 (£24). Display expansion kit approx. 30 lines x 54 characters £15 (£20). Case £23 (£26). Colour conversion board fully assembled £55 (£55). Cassette recorder £13 (£15). Extended monitor £20 (£20). Assembler/Editor £25 (£25). 610 Expansion Board £160 (£160). Minifloppy with psu and 2 copies DOS £275 (£275).

SHARP MZ-80K



The brilliant new Japanese computer 20K ram expandable to 48K. Built in VDU screen, music function and cassette. Displays 40 characters x 25 lines and 80 x 50 on graphics. £465 + 15% VAT.

SUPER PRINT 800MST



The ideal impact matrix printer for Superboard, UK101, Pet, Apple, TRS80, MZ 80K. 60 lines/minute. 72, 80, 96, 120, and 132 chr/line. Tractor and friction feed. Graphics and user definable chr sets. RS232, 20ma, IEEE488 and centronics I/O. SPECIAL OFFER: — Supplied with free word processor program and interface components £359 + 15% VAT.

**SWANLEY ELECTRONICS**

Dept. PC., 32 Goldsel Rd., Swanley, Kent BR8 8EZ.  
Mail order only. Please add 35p postage. Prices include VAT unless stated. Lists 27p post free. Overseas customers deduct 13% Official credit orders welcome.

• Circle No. 271

• Random access, block addressable.

• Operates in adverse environments.

• Connects to standard serial interface EIA.RS232, RS422, RS423.

• Baud rate selection 150 to 38,400.  
• 6 Megabyte serial.  
• Portable or rack mounted units. £850

## TWIN TAPE 58. COST EFFECTIVE ACCESS AND STORAGE

A flexible means of data access and data transfer at a low cost. The Twin Tape 58 costs only £850 which includes\* — • Full 90 day on-site parts and labour warranty • Delivery from stock • Connection cable. You get a lot more for your money from Midlectron.

\* U.K. Mainland Only

DEALER DISCOUNTS AVAILABLE



**MIDLECTRON**

Midlectron Limited, Midlectron House, Nottingham Road, Belper, Derby DE5 1JQ  
Telephone: Belper (0773 82) 6811

S. & S.W. Regional Office: Telephone: Portsmouth (0705) 750506  
S.E. Regional Office: Telephone: 01-550-3834

• Circle No. 272

# COMPUTECH for apple

# COMPUTECH for ITT

Well proven software (several hundred packages already licensed) for business applications on the ITT 2020 and Apple microcomputers.

*Prices excluding V.A.T for cash with order, F.O.B London NW3*

PAYROLL	(300+ Employees, 100 Departments, hourly, weekly, monthly. Very powerful but easy to use).	£375
SALES LEDGER	(500+ Accounts, 100 Departments).	£295
PURCHASES LEDGER	(500+ Accounts, 100 Departments).	£295
GENERAL (OR NOMINAL) LEDGER	(1000 Accounts, 100 Analyses, multi-purpose package).	£295
UTILITIES DISK 1	(Diskette patch, slot to slot copy, zap etc).	£20
APPLEWRITER	(Word Processing)	£42
VISICALC	(Financial Modelling, Costing, Analysis)	£95

## AND NOW HARDWARE!

COMPUTECH DIPLOMAT H/S SERIAL INTERFACE £80

This card has been designed and built to the same professional standards that have resulted in the success of our software. The DIPLOMAT observes the proper "handshaking" protocol so that you can drive fast printers and send and receive data from other peripherals at high speeds without loss of data. Switch (& software) selectable baud rates to 19200 and many other options. Plug compatible with 'terminal' or 'modem' wired peripherals. Guaranteed.

MICROLINE M80 PRINTER £450

This neat, reliable machine prints at 10 characters per inch, 80 characters on an 8 inch line, or 40 expanded characters, or 132 very readable characters, upper and lower case and graphics, 9 x 7 dot matrix, 6 or 8 lines per inch. Parallel interface is standard, serial optional. Both friction and sprocket feed are standard, tractor optional. We can also supply the parallel interface card for Apple System computers for £80 and a driver to enable both text and graphics to be used. Optional custom colour matching for Apple or ITT.

THE FABULOUS MICROMUX 8000 from £800

This is a brand new product, an asynchronous serial multiplexor with up to 16 ports, any one of which may communicate with any other independently, like a 'telephone exchange' for data! Built in test function. Firmware may be customised for special applications. Available in multiples of 4 ports up to 16.

## COMPUTECH SYSTEMS

168, Finchley Road, London NW3 6HP. Tel: 01-794 0202

AGENTS THROUGHOUT THE UK AND OVERSEAS

• Circle No. 273

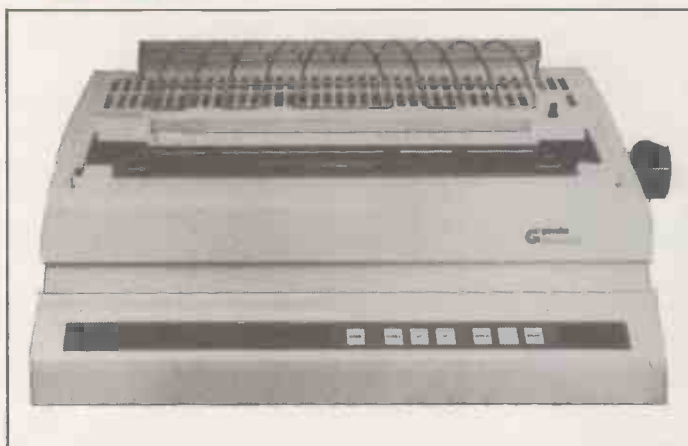

**Diablo 630**

- Interchangeable Metal/Plastic Print Wheels
- Automatic Bi-directional Printing
- Word Processing Options
- Diablo Quality and Reliability
- Paper Handling Accessories

Our volume buying means competitive pricing for our OEM's. Our size and reputation ensure reliability and support not only in Britain but across Europe. Extensive stocks mean we can usually deliver when others can't.

**FOR INNOVATIVE DISTRIBUTION TO OEMs**

**Call us..** Geveke Electronics Ltd. RMC House. Vale Farm Rd. Woking.. **04862 71337**

• Circle No. 274



**DATA DESIGN  
TECHNIQUES LTD**

**AT LAST! PERIPHERALS AT  
PRICES YOU CAN AFFORD**

LA34 DA 30 cps Keyboard Printer	£540
Anadex DP8000	£399
Tally T1612	£1299
DEC VT100	£850

**AND MANY MORE BARGAINS**

Call your nearest office before making any decisions.

12 Leeming Rd  
Borehamwood  
Herts. WD6 4DU  
01-207 1717

Glasgow 041-221 9761

58-60 Northfield Rd  
Kings Norton  
Birmingham B30 1JH  
021-459 5959

Telex 498280



**DDT MAINTENANCE  
LTD**

**WE OFFER COUNTRYWIDE  
MAINTENANCE ON VIRTUALLY  
ANYTHING**

**IF YOU'VE GOT IT WE  
SHOULD BE ABLE TO REPAIR IT**

Workshop repairs our speciality.

Call your nearest office for details.

5-6 Lower Church St  
Chepstow  
Gwent NP6 5EJ  
029-12 2193

Reading 0734-481009

• Circle No. 275

# LINK-ON GIVES YOU REAL WORLD CONNECTIONS IN ALL THE RIGHT PLACES.

LINK-ON is a LOW COST local and remote interface for use with ANY COMPUTER fitted with a serial link, such as DEC, Intel and Personal Computers.

A single LINK-ON handles 24 digital signals (5-240v) or 16 analog signals (20mV-2V), expandable to hundreds per serial link simply by adding further LINK-ON's in multidrop fashion.

Dealer enquiries invited.

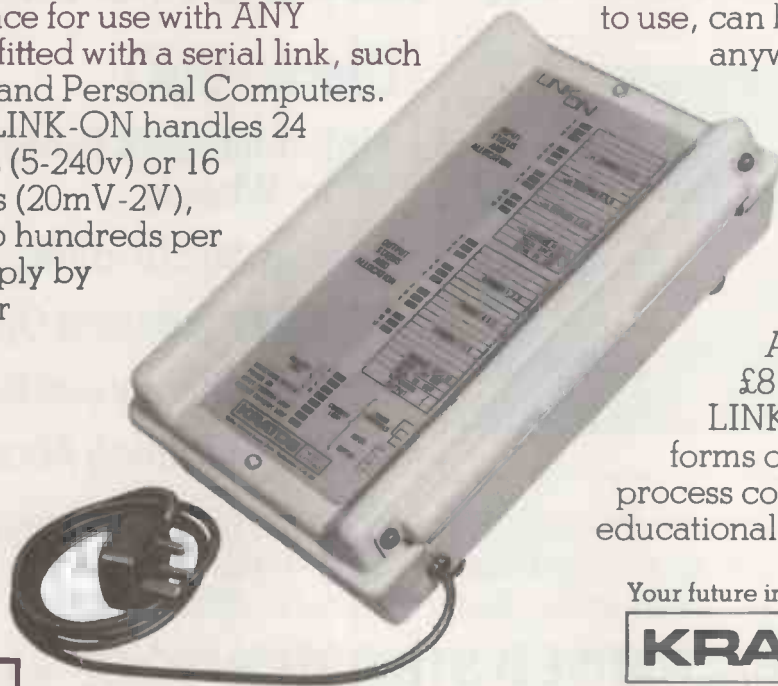

LINK-ON is ROBUST, EASY and SAFE to use, can be positioned almost anywhere and is complete with Klippon terminals, signal isolation and indication, power supplies and watchdog alarm facilities.

All this from as low as £8 per channel makes LINK-ON ideal for all forms of data acquisition, process control, scientific and educational applications.

Your future in control and technology

**KRATOS** Instem Limited

Walton Industrial Estate, Stone, Staffs. ST15 0LT. Tel: 0785 812131. Telex: 36340

• Circle No. 276

## Successful business?... Yes, with the megamicro

average installed system  
less than **£8000** plus VAT

complete with  
**Hardware including printer**  
**Software including programs**  
**Staff training**  
**Installation & delivery**  
**Support by manufacturer**

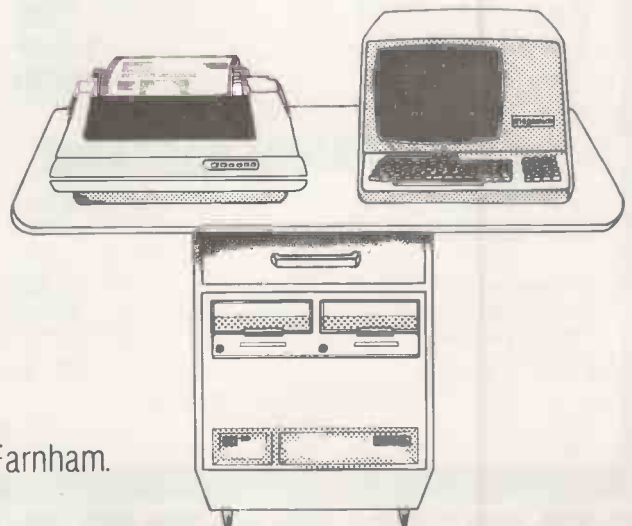

British built by:  
 Bytronix Microcomputers Ltd, 83, West Street, Farnham.  
 Telephone: (0252) 726814

• Circle No. 277



# APPLE® II DISK DRIVES

## DUAL DISK UNIT

£498

## DISK CONTROLLER CARD

£ 49

- \* Two Disks in one Cabinet
- \* Has its own Power Supply Unit
- \* Connects to standard Apple Disk Controller Card
- \* Runs all Apple Software including Pascal
- \* Japanese quality and reliability



APPLE DEALERS:- Write or phone direct to Cumana and specifications plus dealer discounts will be mailed to you.

# TRS-80® DISK DRIVES

## DUAL DISK UNIT

2 x 40 Track Drives  
2 x 80 Track Drives

£440  
£645

## SINGLE DISK UNIT

1 x 40 Track Drive  
1 x 80 Track Drive

£236  
£345

## TRS 80 DISK CABLES

2 Drive Cable  
4 Drive Cable

£20  
£32.50

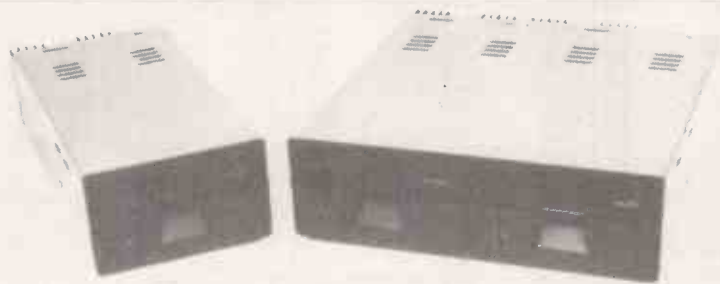

TRS-80 DEALERS:- Write or phone direct to Cumana and specifications plus dealer discounts will be mailed to you.

# MAIL ORDER MINI FLOPPY DISK DRIVES

	Qty	Price Each
TEAC FD-50A 40 TRACK 5¼ inch	1-5	£155
DOUBLE/SINGLE DENSITY DRIVES	6-12	£145
PRICE INCLUDES WARRANTY, SPECIFICATION MANUAL AND MAINTENANCE MANUAL	13-25	£135



Call your nearest dealer for a demonstration:

RADIO SHACK LTD.,  
188, Broadhurst Gardens,  
London NW6  
Tel: 01-624-7174

TRANSAM COMPONENTS  
LTD., 59-61, Theobalds Road,  
London WC1  
Tel: 01-405-5240

PORTABLE MICRO-  
SYSTEMS, 1B, Market Place,  
Brackley, Northants  
Tel: 0280-702017

HEWART MICRO-  
ELECTRONICS, 95, Blakelow  
Road, Macclesfield.  
Tel: 0625-22030

COMPSHOP LTD., 14, Station  
Road, New Barnet, Herts.  
Tel: 01-441-2922

N.I.C. 61, Broad Lane,  
Tottenham, London N15  
Tel: 01-808-0377

COMPUTERAMA LTD.,  
5, Cleveland Place East,  
London Road, Bath.  
Tel: 0225-333232

HARDEN MICROSYSTEMS,  
28-30, Back Lord Street,  
Blackpool. Tel: 0253-27590

COMPSHOP LTD.,  
311, Edgware Road,  
London W2. Tel: 01-402-8847

KATANNA MANAGEMENT  
SERVICES, 22, Roughtons,  
Galleywood, Chelmsford.  
Tel: 0245-76127

ENSIGN, 13-19, Milford  
Street, Swindon, Wilts.  
Tel: 0793-42615

MICRO CHIP SHOP,  
197, Waterloo Road, Blackpool.  
Tel: 0253-403122

MICRO-CONTROL LTD.,  
224, Edgware Road,  
London W2. Tel: 01-402-8842

I.C. ELECTRONICS,  
Flagstones, Stede Quarter,  
Biddenden, Kent.  
Tel: 0580-291816

SEVET TRADING, 14, St.  
Paul's Street, Bristol 2  
Tel: 0272-697757

MICRO CHIP SHOP,  
190, Lord Street, Fleetwood,  
Lancs. Tel: 03917-79511

LONDON COMPUTER  
CENTRE, 43 Grafton Way,  
London W1. Tel: 01-388-5721

CAMBRIDGE COMPUTER  
STORE, 1, Emmanuel Street,  
Cambridge. Tel: 0223-65334

PARWEST LTD., 58, Market  
Place, Chippenham.  
Tel: 0249-2131

EWL COMPUTERS LTD.,  
8, Royal Crescent, Glasgow.  
Tel: 041-332-7642

**CUMANA LTD** 35 Walnut Tree Close, Guildford, Surrey, GU1 4UN,  
Telephone: (0483) 503121. Telex: 859680 (Input G).

Please add VAT to all prices.  
Delivery at cost will be advised  
at time of order.

• Circle No. 278

TTLs by TEXAS		74173	120p	74LS161	75p	4002	20p	4560	200p	PERIPHERALS	4044-4	600p	D58836	150p	8MHz UHF Mod.		
7400	11p	74174	90p	74LS162	140p	4006	95p	4569	250p	3242	800p	4116-2	300p	D58838	225p	5100 Busboard	
74500	60p	74175	85p	74LS163	100p	4007	20p	4572	40p	3245	450p	4118-4	1200p	MC1488	75p	16 Key Pad	
7401	12p	74176	90p	74LS164	90p	4008	80p	4583	110p	6522	700p	5101	400p	MC1489	75p	5100 Busboard	
7402	14p	74177	90p	74LS165	140p	4009	40p	4584	90p	6532	800p	6810	300p	MMS18174	1200p	1500p	
7403	14p	74178	160p	74LS166	180p	4010	50p	4585	150p	6820	375p	4016-4	P.O.A.	75107	160p	DIN4161 2 Plug	
7404	14p	74180	93p	74LS173	110p	4011	20p	4724	250p	6821	340p	(2K x 8 Static)	P.O.A.	75110	250p	450p	
7405	18p	74181	160p	74LS174	100p	4012	25p	40097	90p	6850	300p	4532-2	P.O.A.	75154	175p	DIN4161 2 Socket	
7406	36p	74182	90p	74LS175	100p	4013	50p	14411	1100p	6852	370p	(4K x 8 Dynamic)		75182	230p	450p	
7407	36p	74184A	150p	74LS181	320p	4014	84p	14412	1100p	8155	1100p			75324	375p	43 way Edge Con	
7408	17p	74185	150p	74LS190	100p	4015	84p	14433	1100p	8205	320p			75361	300p	250p	
7409	17p	74186	500p	74LS191	100p	4016	45p	14500700p		8212	225p	ROMS		75363	400p	31 way Plug 0.1"	
7410	15p	74188	325p	74LS192	100p	4017	70p	14599	290p	8216	225p	745188	275p	75365	200p	120p	
7411	24p	74190	120p	74LS193	100p	4018	80p			8224	275p	745189	275p	75451/2	72p	31 way SKI 0.1"	
7412	20p	74191	120p	74LS194	100p	4019	45p			8226	400p	745201	350p	75491/2	70p	120p	
7413	30p	74192	100p	74LS195	140p	4020	100p			8228	525p	745287	350p	8T26	160p	Logic Probe LP1	
7414	40p	74193	100p	74LS196	120p	4021	110p			8251	475p	745387	350p	8T28	250p	£31	
74C14	90p	74194	120p	74LS197	90p	4022	100p			8253	1000p	745470	650p	8T95	200p	Logic Probe LP2	
7416	27p	74195	95p	74LS221	120p	4023	27p	1600	1200p	8255	450p	745471	650p	8T97	160p	£18	
7417	27p	74196	95p	74LS240	175p	4024	50p	1802C	700p	825	900p	745472	900p	81LS95	120p	Logic Probe LP3	
7420	17p	74197	80p	74LS241	175p	4025	20p	2650A	1600p	8259	950p	745571	900p	81LS96	140p	£49	
7421	40p	74198	150p	74LS242	170p	4026	130p	6502A	950p	8279	POA	745573	900p	81LS97	120p	Vero DIP Board	
7422	22p	74199	150p	74LS243	170p	4027	50p	6800	650p	MC14411	1100p	(Many more stocked)		81LS98	140p	325p	
7423	34p	74221	160p	74LS244	150p	4028	84p	6809	2500p	MC14412	1100p	EPROMS		81LS99	140p	Vero DIP Board	
7425	30p	74251	140p	74LS245	250p	4029	100p	INS8060	1000p	Z80A-CTC	600p	1702A	700p	9601	110p	(with 31 way Edge)	
7426	40p	74259	250p	74LS247	140p	4030	55p	8080A	450p	Z80A-PIO	700p	2708	400p	9602	220p	390p	
7427	34p	74278	290p	74LS251	140p	4031	200p	8085A	1100p	Z80-PIO	600p	2716(+5v)	700p			Wine Wrapping	
7428	36p	74279	110p	74LS253	90p	4034	200p	9980	3600p	Z80A-PIO	700p	2732	2500p			accessories and	
7430	17p	74283	140p	74LS255	90p	4035	110p	Z80	750p	Z80-SIO-1	2400p					tools stocked.	
7432	30p	74284	360p	74LS258	160p	4039	295p	Z80A	950p								
7433	40p	74285	360p	74LS259	160p	4040	100p										
7437	35p	74290	150p	74LS266	100p	4041	80p										
7438	35p	74293	150p	74LS273	170p	4042	80p										
7440	17p	74298	200p	74LS279	90p	4043	90p										
7441	70p	74365	100p	74LS283	90p	4044	90p										
7442A	60p	74366	100p	74LS298	160p	4046	110p										
7443	112p	74368	100p	74LS323	400p	4047	110p										
7445	100p	74390	200p	74LS324	200p	4048	55p										
7446A	93p	74393	225p	74LS348	200p	4049	48p										
7447A	75p	74490	200p	74LS365	48p	4050	45p										
7448	80p			74LS368	100p	4051	80p										
7450	17p			74LS373	150p	4052	80p										
7451	17p			74LS377	120p	4053	80p										
7453	17p			74LS378	160p	4054	150p										
7454	17p			74LS379	140p	4055	125p										
7460	17p			74LS390	120p	4056	135p										
7470	36p			74LS393	120p	4059	600p										
7472	30p			74LS399	200p	4060	115p										
7473	34p			74LS445	140p	4063	110p										
7474	30p			74LS460	450p	4066	50p										
7475	38p			74LS461	450p	4067	450p										
7476	32p			74LS462	450p	4068	27p										
7480	50p			74LS464	450p	4069	20p										
7481	100p			74LS468	450p	4070	20p										
7482	84p			74LS668	100p	4071	25p										
7483a	90p			74LS670	250p	4072	25p										
7484	100p					4073	25p										
7485	110p					4075	25p										
7486	34p					4076	107p										
7489	210p					4081	27p										
7490A	30p					4082	27p										
7491	80p					4086	172p										
7492A	46p					4089	75p										
7493A	36p					4093	70p										
7494	84p					4094	250p										
7495A	80p					4095	95p										
7496	65p					4096	95p										
7497	180p					4097	340p										
74100	130p					4098	120p										
74107	34p					4099	200p										
74109	55p					4100	220p										
74116	200p					4101	132p										
74118	130p					4102	180p										
74119	210p					4103	190p										
74120	110p					4104	90p										
74121	34p					4105	120p										
74122	48p					4106	90p										
74123	60p					4107	60p										
74125	75p					4108	470p										
74126	60p					4109	100p										
74128	75p					4110	300p										
74132	75p					4111	250p										
74136	75p					4112	120p										
74137	50p					4114	250p										
74141	50p					4115	50p										
74142	200p					4116	70p										
74145	90p					4117	55p										
74147	90p				</												



# SORCERER

CP/M™  
S100  
Z80

For the serious user:  
**Business  
Education  
Amateur**

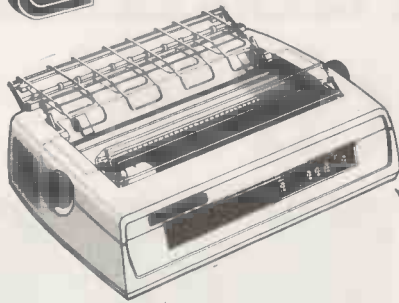

PIO + RS232/20ma serial O/P  
Dual 1200 baud cassette O/P

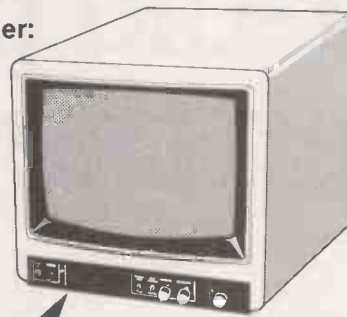

Memory mapped  
30 lines × 64 characters  
upper/lower case + 128  
programmable graphics



SORCERER  
16-48K internal RAM  
Z80 CPU, 4K monitor

Video or UHF

6 slot S100 expansion  
(not illustrated)

ROMPAC

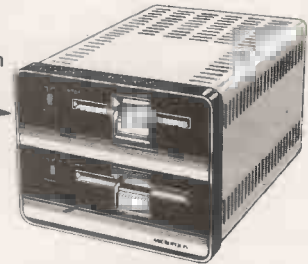

Micropolis 630K dual disk  
CP/M or Micropolis MDOS

## STANDARD SORCERER

- \* Displays 30 lines of 64 characters - more than any other personal computer. 79 key stepped typewriter-style keyboard with separate numeric pad for fast data entry.
  - \* Plug in ROMPAC cartridges for programming languages, special applications (e.g. word processing) or creating a user's dedicated system. Sorcerer is supplied with 8K Microsoft BASIC ROMPAC
  - \* Composite video output for video monitor or UHF output for use with an unmodified TV set at nominal extra charge.
  - \* Z80 CPU with up to 48K RAM on-board.
  - \* 4K power-on monitor in ROM allowing machine code programming, batch processing, memory transfers and copying, alteration of memory locations, use of cassette files.
  - \* Dual 300 or 1200 baud cassette ports with motor control
  - \* Parallel I/O port and serial RS232 port for direct connection to printers or use as a terminal to a larger computer - no expensive 'extra' communications interfaces
  - \* Full upper/lower case ASCII characters plus 128 user programmable graphics (64 default to standard graphics symbols if undefined). Default graphics above ordinary characters on keytops.
- 16K £749.00    32K £799.00    48K £849.00

## Expansion Capabilities

- \* 6 slot S100 expansion for memory up to 56K RAM, disc drives (5 1/4" or 8") etc. Standard bus means that you are not dependent on equipment from a single manufacturer **£240.00**
- \* Micropolis double density 5 1/4" drives with MDOS and Disc BASIC:  
First drive (incl. controller card) single 315K **£690.00**  
Additional drives (max 4 drives/controller) 315K **£390.00**
- \* FDM 180 Disk Unit: Micropolis Disk Drive, plugs directly into Sorcerer, does not require S100 Unit:  
Single 315K Disk Drive (c/w CP/M and Microsoft BASIC) **£599.00**  
Single 315K Add-on Disk Drive. **£450.00**
- \* CP/M industry standard disk operating system **£75.00**
- \* Development ROMPAC - Z80 assembler, loader, editor, debugger **£70.00**
- \* EPROM PAC for loading dedicated software up to 16K **£35.00**
- \* Configuring programs allow Sorcerer to be used as a 'dumb' terminal or, with CP/M, as an intelligent terminal.

## Programming Languages

The following programming languages are available for CP/M:

Microsoft Disk BASIC interpreter (BASIC 80 - compatible compiler), CBASIC2 (compiled BASIC), FORTRAN 80 and COBOL-80, ALGOL 60 - A Z80 system with graphics, string handling and random-access filehandling.

All Exidy products are covered by 12 months warranty.  
CP/M™ is a trademark of Digital Research.  
All prices exclusive of VAT

## THE WORDPROCESSING WIZARD!

Sorcerer's upper/lower case typewriter keyboard and unusually large display (30 lines of text; approximately equivalent to one double-spaced typed page) makes it ideal for word processing applications. The Exidy word processor PAC is a sophisticated screen editor and text formatter with automatic text wrap-around, left and right justification, proportional letter spacing (on disk only with Spinwriter) and many other formatting facilities. It can also search for and replace strings, move and merge blocks of text and a macro facility allows specification of tasks such as mail-merge letter typing. Letters and texts can be stored on cassette or disks (one disk will store approximately 300,000 characters and costs less than five pounds. 32K or 48K RAM is recommended.

Word Processor PAC **£120.00**    Disk Version: **£118.75**

C.Itoh 8300 dot matrix printer -40, 80 and 120 characters per line on 9 1/2" wide paper, 125 characters/second, upper/lower case, tractor feed, forms positioning **£499.00**

NEC Spinwriter solid font printer -variable horizontal and vertical spacing, proportional spacing, interchangeable fonts, carbon or fabric ribbon, 55 characters/second, paper up to 16" wide **£1,900.00**

Example system: 32K Sorcerer, video monitor, FDM 180 Disk Unit with CP/M and Microsoft BASIC, C.Itoh 8300 printer, Word Processor on disk and CP/M. **£2,225.00**

## Business Software

Besides its word processing capabilities, Sorcerer can run a wide range of business software thanks to the widely used CP/M disk operating system available for the Micropolis disk drives. Programs available include:

Payroll: (requires CP/M and CBASIC2) **£250.00**

General Ledger, Job Costing, Accounts Receivable, Accounts Payable: (all require CP/M and CBASIC2) **£335.00 each**

For further information and list of dealers,  
please contact the sole U.K. distributors.

GEOFF WILKINSON, Dept. PC.1

# LIVEPORT

## DATA PRODUCTS

The Ivory Works, St. Ives, Cornwall TR26 2HF  
Telephone: (0736) 798157

PLEASE SEND DETAILS OF THE EXIDY RANGE/WORD PROCESSOR

NAME \_\_\_\_\_

ADDRESS \_\_\_\_\_

PC11

• Circle No. 280

# What will you do with 12-year-old programmers when they reach 16?

Any microcomputer is a major investment for an educational establishment. Many potential users feel that a BASIC only computer is ample for their needs. That may be fine today, but with computer education starting so early you may in a surprisingly short time find you want more than current implementations of BASIC.

The 380Z is a computer that can grow to match your needs.

In the design of the 380Z our target user is the graduate research scientist. This ensures that the expandability and versatility needed tomorrow has been provided for in the computer you buy now.



Might you want to add disc storage in the next few years?

*If you do:*

Given good hardware, software availability completely determines the flexibility and usefulness of your system. There is absolutely no question that a Z80 based micro-computer which uses the industry-standard CP/M\* disk operating system has several times more software on the market available to it than non CP/M computers.

Today you can purchase a mature CP/M BASIC, FORTRAN, COBOL or Text Processor for the 380Z. Soon there will be CP/M Pascal and Database Management systems.

CP/M software is several years ahead of software available for non CP/M family machines.

*If you don't:*

Remember that professionals writing packages for your cassette system will themselves often use a disk 380Z, and the power of their tools will influence what they produce.

For many people a disk machine is too expensive – but at least the 380Z

approach will allow your students to advance.

380Z BASIC is not frozen in ROM. An enhanced BASIC could be loaded in mid 1980 and a BASIC with structured features sometime later.

On the 380Z the memory used by a BASIC interpreter can also be used for other software.

Does our research-oriented design pay off in classroom hardware?

Our scientific graphics was produced for the professional user. Interest in it for classroom use has been surprising.

The 380Z has the best graphics now available on a microcomputer,

allowing multiple resolutions, multiple paging, fading and accurate control over colour. All these features help bring excitement to efforts in computer assisted learning.

Our standard machine comes with low resolution graphics and support for this from BASIC allows you to plot a point directly with a plot command – useful for training and teaching.

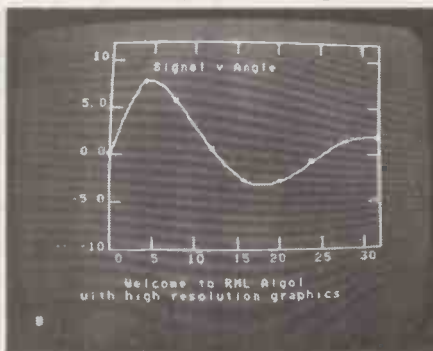

It is worth remembering too that neither our low resolution graphics nor our optional scientific (high resolution) graphics has any limiting effect on your memory usage, and in both you can



freely mix upper and lower case text and diagrams.

Mains noise can cause system crashes which result in loss of programs and data. All current 380Zs include a mains filter which significantly reduces the chances of this happening.

Don't buy a 380Z on patriotic grounds.

Please only buy it if you would have bought it anyway. But remember, because it is designed and manufactured here you are bound to have better access to us for influence and help than if we were on the other side of an ocean.

Prices range from a 16K cassette 380Z @ £897 to a 56K Dual Full Floppy Disk 380Z @ £3322.

## LOWER COSTS

- Three things have happened which make it easier to buy a 380Z.
- ONE: From 1st November 1979 most prices have been reduced.
- TWO: Schools and some colleges can now get a 5% discount on computer orders.
- THREE: A new Local Authority quantity discount scheme has been introduced to make it easier for more users to benefit from quantity purchasing.
- Please contact the Sales Office for details.

## RESEARCH MACHINES

RESEARCH MACHINES Ltd,  
PO. Box 75, Mill Street, Oxford, England.  
Telephone: Oxford (0865) 49791/2/3.  
Please send for full sales information.  
Prices do not include shipping costs or VAT @15%.

\* Trademark, Digital Research.

• Circle No. 281

Quality Software at a reasonable price – available direct from your local dealer.

# CORDEX

## CORPLAN

The Educational Management Game. Production, Finance, Accounts, Marketing. You are in the hot seat running your own company. Instant feedback of business results.

TRS-80 Model I or PET  
Good training manual  
£39.95/£69 incl VAT.

Personnel Records  
Prospects Lists  
Club Directories  
Mailing Lists  
Client Address Lists  
Contacts' Phone Nos  
Territory Indexes  
Cross Reference Files: —  
Highly selective.  
Automatic file creation facilities.  
Comprehensive manual  
Sold by Tandy as  
TANDY MAIL.  
TRS-80 Model I or II.  
£89.95/£125 incl VAT

## CORPLAN II

Enhanced Corplan by popular demand!  
Uses 48K, disk, printer, for storing decisions and printing results.

TRS-80 Model I  
£79.95 incl VAT.

UNDERSTANDING  
MICRO-COMPUTER SERVICES

For further details ask your dealer or write to:

UNDERSTANDING LTD. 54 MOUNTFIELD ROAD, LONDON N3 3NP

# Introducing HP-41C

## A powerful new calculator - with its own peripherals!

A new Hewlett-Packard calculator is always a special event. But the new HP-41C is especially special!

It's a fully programmable calculator - advanced, powerful and very versatile. Yet it's also remarkably easy to use, with a helpful alphanumeric display and a range of application modules.

Most important, it has its own dedicated peripherals - including printer, card reader and memory modules.

### A unique machine

**Program power.** 400 lines of program memory (or 63 data storage registers) as standard, expandable up to 2000 lines (319 data storage registers). With RPN logic, for faster problem-solving.

**Alphanumeric display.** You can name and label programs, functions, variables and constants. The calculator uses words and sentences to prompt for data. The display shows calculator modes and status.

**'Customise' feature.** Assign any of 68 keyboard functions (or 130 library functions) - or any program you've written yourself - to any key on the HP-41C. To help you, the HP-41C comes with keyboard overlays. (Each assigned function or program name is displayed prior to execution.)

**Continuous Memory.** Maintains program and data when your HP-41C is switched off. Simply switch on, and continue with your calculation.

### A unique system

Look at this impressive list of add-on peripherals!

**HP-41C printer.** Quietly gives numeric, upper and lower case alpha characters, in single and double width, as well as special characters. And performs high resolution plotting routines.

**Application modules.** For engineers, students, businessmen, scientists and others. Instantly converts your calculator to a specialised discipline.



**HP-41C card reader.** Saves program and data on magnetic cards. Keeps track of cards as they're read, and prompts you for the next card.

**Memory modules.** Each contains 64 data storage registers (400 program lines, or any combination).

**Incredible value at £192.55 (including VAT)!**

This price includes the calculator, 63 registers for data or programs, owner's handbooks, overlay kit, zip-up pouch and batteries! Compare the HP-41C with other calculators in its price range. You'll find it has more functions and more options. See your dealer for a demonstration - you'll find his name below.



**Aberdeen** Tyseal Typewriter Services. **Belfast** Cardiac Services Company. **Birmingham** Anglo American Computing; John Mabon Associates; Taylor Wilson. **Bolton** T & R Office Equipment. **Bournemouth** South Coast Business Machines. **Brighton** Office Machinery Engineering Co. **Bristol** Decimal Business Machines; Wilding Office Equipment. **Bromley** Wilding Office Equipment. **Cambridge** W. Heffer & Sons. **Canterbury** R. E. Typewriters. **Cardiff** Sigma Systems (Calculators). **Carlisle** Thos. Hill Group. **Chelmsford** Automatic & Electronic Calculators. **Colchester** Wilding Office Equipment. **Croydon** Landau Calculators; Wilding Office Equipment. **Derby** Office Machines. **Dundee** Tayside Office Equipment. **Edinburgh** Business & Electronic Machines; Holdene. **Folkestone** R. E. Harding. **Glasgow** Robox. **Gloucester** Wilding Office Equipment. **Grimby** Teesdale Office Equipment. **High Wycombe** A. C. Barratt & Co. **Ilford** Wilding Office Equipment. **Ipswich** Anglo Business Machines; Wilding Office Equipment. **Kingston-upon-Thames** Wilding Office Equipment. **Leeds** Holdene; T & R Equipment. **Leicester** A. C. Barratt & Co.; Sumlock Services. **Liverpool** Rockliff Brothers. **London** Automated & Electronic Calculators; City Business Machines, 57 Houndsditch, Bethnal Green Road; Concept Business Machines; Dixons Photographic, 64 New Bond Street; Euro-Calc Limited, 128-132 Curtain Road, 224 Tottenham Court Road, 55 High Holborn; Landou Calculators, Bourne's, Oxford Street, 227 Tottenham Court Road; Logic Box; McDonald Stores; Metyclean, 137 The Strand, 92 Victoria Street; Mountindene; Reid's Office Equipment; Sumlock-Bondain, 15 Clerkenwell Close, Cannon Street Station; Wallace Heaton; Wilding Office Equipment, 7 The Arcade Hoe Street, 21 Thomas Street, 120 The Broadway, Wimbledon. **Luton** Wilding Office Equipment. **Maidstone** Wilding Office Equipment. **Manchester** Automated Business Equipment; Holdene; T & R Office Equipment. **Matlock** Derby Office Machines. **Middlesbrough** Thos. Hill Group. **Newcastle** Thos. Hill Group. **Northampton** A. C. Barratt & Co. **Norwich** Leamons Office Machines; Sumlock-Bondain. **Nottingham** Bennett's (Typewriter & Office Supplies); Trent Office Equipment. **Oxford** Reid's Office Equipment; Science Studio. **Plymouth** JAD Integrated Services. **Reading** Central Southern Calculators; Reid's Office Equipment. **Caversham**, 38 Market Place, Reading. **Romford** Wilding Office Equipment. **Royston**, Herts. Electroplan. **Sheffield** Butlers Office Equipment. **Slough** Wilding Office Equipment. **Southampton** South Coast Business Machines. **Southend** Wilding Office Equipment. **Sunderland** Thos. Hill Group. **Sutton** Landou Calculators. **Swindon** Wilding Office Equipment. **Waltham Cross** Wilding Office Equipment. **Watford** Automatic & Electronic Calculators; Wilding Office Equipment. **Worthing** Office Machinery Engineering Co. **All UK branches of Comet.** **CHANNEL ISLANDS:** Guernsey P.B.S. Jersey Professional Business Systems. **EIRE:** Dublin Abacus Systems.

• Circle No. 283

# We specialise in big help for buyers of small systems.

Lots of people feel they need help when it comes to choosing and buying a business computer.

That's why they come to NSC Computer Shops.

We are specialists and we have the most experience. So we can give the most expert advice.

We also offer the widest range you could wish to see.

Plus a total back-up including consultancy, software and continuing support. And you get a good deal, price-wise.



## Pet

A popular and very reliable small business system used for accounting, word processing, mailing lists and other office tasks. NSC's attractive prices on all models of the Pet make it a very sound investment.

## South West Technical Products

A middle priced business computer widely used for word processing, and a big time saver on things like mailing lists. NSC have stocks of disc drives, both 8" and 5¼" and memory boards and interface cards, with reductions of up to 40% on some items. Also available are processor cards to upgrade to 6809, and a complete range of 6809 equipment.



## North Star Horizon

A complete word processing system extendible from 32K-56K RAM, up to four mini disc drives, 4MHz Z80A processor, serial and parallel I/O ports and extended BASIC. NSC have a full range of accounting packages available for this system, which has also proved very popular in educational and industrial applications. You can lease it over a five year period for as little as £25 per week.

## Apple

Manchester's first Apple dealer. We will be pleased to demonstrate any of the exciting products which are now available with the Apple, including voice recognition, graphics tablet etc.

## Cromemco

Top quality computer systems backed by complete software service for word and data processing. The only microcomputer currently available with RPG II.

## Centronic 779 for £779

The most robust low cost printer around. At a special reduced price of £779 while stocks last.

## Acorn Atom

Come and try this new budget priced computer at NSC Computer Shops. Kit machine available from £120.

## Shop at NSC and get a better deal.

Ring 061-832 2269 for further information.

# NSC COMPUTER SHOPS

Here to help

NSC Computer Shops, 29 Hanging Ditch, Manchester M4 3ES

• Circle No. 284

## COMPLETE SYSTEMS

### NEW SUPERBRAIN DOUBLE DENSITY £1595 QUAD DENSITY £1995

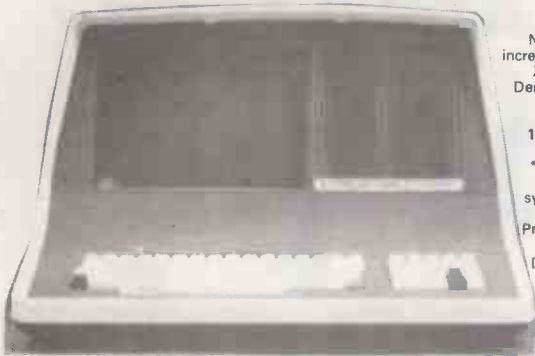

Now with CP/M2.2, and increased disc storage. Twin Z80-A 4MHz. \*2 Double Density Disc Drives, giving 350/700K storage \*64K RAM. \*High resolution 12 inch crt. 80 x 24 lines upper/lower case \* 2 RS-232 printer ports. \* CPM 2.2 operating system. \*MBasic, Cobol, Fortran, Pascal, Word Processing and Accounts packages available. Dealer Enquiries Invited.

### TRS-80 MODEL II £1999



State of The Art Second Generation Computer. Over 10,000 already sold in USA. 8 slot bus ensures expansion of hard discs and other peripherals. 76 Key professional keyboard, self test on power up. TRSDOS and Level III Basic Standard. CP/M available as option, making a wide range of accounting, educational, scientific and word processing packages instantly usable. Nationwide service through 180 Tandy Stores and Computer Centres.

### NEW TRS-80 MODEL 1 48K SYSTEM



WITH DUAL DISC DRIVES. £1175 NEW GREEN SCREEN VDU, WITH ROCK STEADY DISPLAY. REDESIGNED 32K EXPANSION INTERFACE WITH TROUBLE FREE DISC OPERATION. TWO 40 TRACK TEAC DISC DRIVES. COMPLETE WITH CABLES. TRIDATA SALES, PURCHASE, INVOICING, PAYROLL PACKAGES AVAILABLE.

#### LOW COST WORD PROCESSOR I

BASED ON TRS-80 LEVEL 2 16K. CASSETTE RECORDER, ELECTRIC PENCIL SOFTWARE, UPPER/LOWER CASE MOD. PRINTER INTERFACE AND OKI DOT MATRIX PRINTER. COMPLETE READY TO GO £1095. FREE MAILING LIST PROGRAM.

#### WORD PROCESSOR II

SAME AS ABOVE BUT WITH 48K, 2 DISC DRIVES AND RICOH DAISY WHEEL PRINTER. £2575.

#### WORD PROCESSOR III

BASED ON SUPERBRAIN COMPUTER SHOWN ABOVE. WITH RICOH PRINTER AND "MAGIC WAND" THE ULTIMATE IN WORD PROCESSING. LETTERS AUTOMATICALLY FORMATTED WITH ADDRESSES FETCHED FROM SEPARATE FILE. COMPLETE SYSTEM. £3395. INVOICING, STOCK CONTROL, SALES LEDGER, PURCHASE LEDGER, PAYROLL AVAILABLE FOR ABOVE COMPUTERS. FROM £250 PER PACKAGE. Prices quoted above do not include VAT. Phone or call for further details or demonstrations.

## PRINTERS

### 60 CHARACTERS PER SECOND

**RICOH RP-1600 THE FASTEST DAISY WHEEL PRINTER.** £1290 FAST, heavy duty commercial DAISY WHEEL printer, with high quality printout, coupled with low noise necessary for office environment. Nationwide service by NEXOS. 90 day warranty provided at your premises.

124 char: upper/lower case. \* 10/12 chars: per inch giving 136 or 163 columns. \* 15 inch wide friction platen. \* Top of the form, BOLDING, underline, and host of other features. \* Centronics type parallel interface as standard. Options: serial interface £60 \* PET interface £65 \* APPLE interface £75.

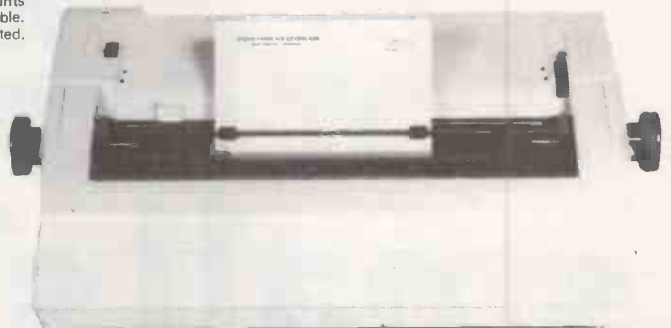

### ANADEX DP-8000 NEW LOW PRICE £475.

Fast 112 Characters per second. \* Both RS-232, and Centronics Parallel interfaces built in \* Upper/lower case £ sign.



**OKI MICROLINE 80/132.** The quiet printer you can live with £449. The quietest Dot Matrix available. 40,80, or 132 cols per line. \* excellent print quality \* 3-way paper handling: Letterheads, Fan-fold, or Paper Rolls \* Graphics \* Ideal for software written for large 132 col printers \* Continuous rating printing day in and day out \* Centronics parallel standard. Options: RS-232, PET, APPLE. Dealer Enquiries invited.

### EPSON TX-80 £349

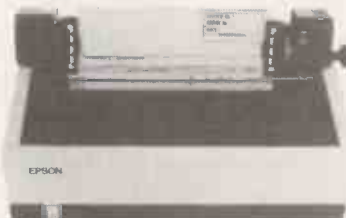

Dot-Matrix Printer with PET Graphics. Prints 80 columns on plain paper at 90 characters/second. Adjustable tractor \* Upper/lower case \* Double width printing \* Micro controlled \* Self test \* Heavy Duty Print Head using Jewell Bearings for long life \* Made by Shinshu Seiki an affiliate of Seiko Watch Co of Japan. Interface: Centronics Parallel. Options: PET, APPLE and Serial.

LONDON COMPUTER CENTRE LTD  
43, GRAFTON WAY,  
OFF TOTTENHAM COURT ROAD,  
LONDON W.1.

TEL 01-388 5721  
OPENING HRS: 11-7 MON-FRI, 12-4 SATS.

NORTHERN DEALER  
MICRO SYS LTD  
58 HIGH STREET  
PRESCOTT  
MERSEYSIDE  
TEL: 051-426 7271

MIDLANDS DEALER  
HORIZON SOFTWARE LTD  
REGENT HOUSE  
16 WEST WALK  
LEICESTER LE1 7NG  
TEL: 0533 556550

• Circle No. 285



# DATA LINK

## Microcomputer Systems Limited

Systems software for business, industrial and scientific applications

### APPLE SYSTEMS

Apple II Plus	£695.00
1 MB 8" Disk Drives	£1,550.00
Disk Drive with controller card	£349.00
Disk Drive without controller card	£299.00
16K Add-ons RAM	£69.00

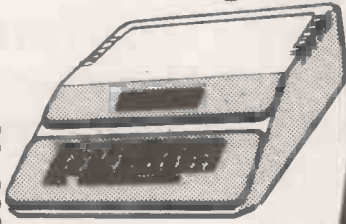

### FULL RANGE OF ACCESSORIES

including:—	
Visicalc	£95.00
ALF Music Synthesizer	£135.00
A1-02 Data Acquisition Card	£180.00
Clock Card	£160.00
ROM Plus Board	£116.00

ALL PRICES EX VAT

### APPLE SYSTEM — Latest Additions

DOS 3.3 (23% extra disc space)	£39.00
H.S. RS232/Bi-directional parallel Combined Interface	£120.00
Desktop Plan (from Visicalc people)	£64.00
H.S. Serial Interface	£80.00
Language Card with Pascal	£299.00
Fortran addition	£120.00
Pilot addition	P.O.A.
Appletel (for Prestel)	£595.00
Apple juice reserve power supply	£148.00
IEEE Interface	£212.00

### Printers

Paper Tiger (with graphics)	£598.00
Centronics 737 (5 character sets, Bi-directional paper drive, R. Margin justification)	£580.00
Centronics 701	£1,115.00
Centronics 702	£1,310.00
Centronics 703	£1,625.00
Centronics 704	£1,655.00
Centronics 753	£1,655.00

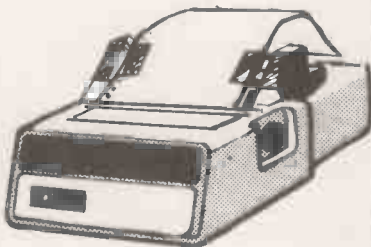

### Consultancy Service

If the computer you buy is really going to do the job you want it to do — run your accounts, control your stock, solve your problem, or you name it . . . the selection of the computer system and the programs to run it must be made with the utmost care. Otherwise, grief, hassle and costly frustration may well be your unhappy lot.

As always, the answer is to consult an expert. We have on tap a team of friendly experts who will happily analyse your problem, discuss with you your hopes and ambitions, and advice you on the feasibility of a computer solution. If the situation is on-going, they will then specify your software requirements and recommend a particular computer system. Finally, they will cost the whole exercise. Fortune smiles upon he who . . .

### DISKETTES ETC

<b>BASF Top Quality Unconditional 12 Month Guarantee</b>		
5.25" Mini Single Sided Soft Sectored/Single Density	£25.00	(Box of 10)
5.25" Mini Single Sided Hard Sectored/Single Density	£25.00	(Box of 10)
5.25" Mini Single Sided Soft Sectored/Double Density	£26.00	(Box of 10)
5.25" Mini Double Sided Soft Sectored/Double Density	£30.00	(Box of 10)
8" Single Sided Soft Sectored/Single Density	£26.50	(Box of 10)
8" Single sided Soft Sectored/Double Density	£27.50	(Box of 10)
8" Double Sided Soft Sectored/Single Density	£40.00	(Box of 10)
8" Double Sided Soft Sectored Double Density	£40.00	(Box of 10)
<b>DISKETTE LIBRARY CASES</b>		
5.25" Mini Diskette Library Case for 10 Diskettes	£2.50	
8" Diskette Library Case for 10 Diskettes	£3.00	
<b>DISKETTE TRAY WITH LOCKABLE LID</b>		
A6 5.25" Mini Diskette Tray with Lockable Lid:		
30-40 capacity	£18.00	
60-80 capacity	£20.00	
A5 8" Diskette Tray with Lockable Lid:		
30-40 capacity	£25.00	
60-80 capacity	£28.00	
9" Plain Listing Paper (per 2,000 sheets)	£16.00	

10% EDUCATIONAL DISCOUNT

### STOP PRESS

#### Programmable Timer for Apple

Software controlled counter/timer for frequency/interval measurement, pulse/event counting, controlled frequency source, etc. 6 input/output channels. 16 bit counter resolution, 2M sec max clocking frequency. Remote stop/start.

£110.00

#### Z-80 Softcard for Apple

You've read about it, we can supply it. Send for full details and specification.

£180.00

WE CAN NOW ARRANGE INSURANCE FOR YOUR COMPUTER

We also stock an extremely comprehensive range of computer books

# DATA LINK

10 Waring House, Redcliffe Hill, Bristol BS16TB  
Telephone: Bristol (0272) 213427

• Circle No. 286

**We believe that we offer the most  
professional range of Business software  
for the Apple II/ITT 2020 in the  
United Kingdom**

**The Financial Controller**

(Pascal Based)  
Sales Ledger  
Purchase Ledger  
General Ledger  
Financial Planning  
Payroll

**The Administration Controller**

Visicalc  
Easywriter 80 Column wordprocessor  
Addressing and Mailing  
Easymover . . . electronic mail  
Database Manager  
Whatsit  
Executive Diary  
Typing Tutor

**The Stock Controller  
The Estate Agent**

**The Librarian  
The Cashier**

Interstat. Advanced Mathematics. Touchwriter. Graph Creator. Bar Chart Creator. Video Message. Little Genius series.  
Coming soon . . . The Teacher — Mathematics. Book-keeping. Payroll. Geography. Physics. Electronics. Optics. Shape Mapper . . . and many more.  
So send today for a free copy of our latest catalogue and we promise to keep you updated.

**Systematics International**



**Microsoftware Division  
Essex House  
Cherrydown  
Basildon, Essex  
Tel: (0268) 284601**

# Practical Computing Back Issues

Each month, *Practical Computing* carries at least one hands-on test of a popular microcomputer for use in business, the home, schools and colleges. Each issue contains the kind of information you need — technical data and for the intelligent professional layman, unbiased critical comment on the strengths and weaknesses of each system or service reviewed.

All this makes *Practical Computing* an invaluable source of whys, wherefores, hows, ifs and butts of microcomputing.

Order your back issues now, by simply filling in our Back Numbers order form bound in every issue.

## October 1978 \*

**Review 1:** Commodore Pet I **Review 2:** VDUs — Computer Workshop Ct-64, Strumech Engineering ACT-1. Music on a KIM; Micro v Calculator; VAT accounting complete program Part 1.

## November 1978 \*

**Review:** Tandy TRS-80. Projects for KIM: Pet goes to school; VAT accounting complete program Part 2; Complete game program — Mastermind; Software Dynamics Basic compiler review.

## December 1978 \*

**Review:** Research Machines 380Z. Choosing your first computer; ITT interview; Complete games programs — Battleships, Racing Cars and Monsters; A microcomputerised reservation system.

## January 1979

**Review:** Nascom I Convert an IBM typewriter into a terminal Part 1; In-car computing — Pet in the Panther DeVille; Report from the Los Angeles Computer Faire; Pascal v Basic.

## February 1979

**Reviews:** Cromemco Z-2D. Low-cost peripherals. Systems for estate agents and doctors; A £1000 payroll system; IBM typewriter conversion Part 2; Complete game program — Warlock Warren.

## March 1979

**Review:** Single-board computers for less than £50 Low-cost stock-control systems; IBM typewriter conversion Part 3; New monthly column — Tandy Forum; Complete game program — NIM.

## April 1979 \*

**Review:** North Star Horizon Business accounting systems; Apple II design story Part 1; Computerised school meals; Finance for school computing; Build your own frequency meter; Star Trek game.

## May 1979

**Reviews:** Exidy Sorcerer, Science of Cambridge Mk 14; Printers for less than £1000; Order processing/invoicing packages; Retire with your computer; Apple II design story Part 2; Slalom game.

## June 1979

**Reviews:** Compucolor II, Ohio Superboard II; Low-cost word-processing; Computing in a pharmacy; Designing a small business application Part 1; Computer v. Brain; Zombie game.

## July 1979 \*

**Reviews:** AIM-65, SOL-20. Choosing your first computer; Interfacing Pet with a mainframe; Nascom story; Designing a small business application Part 2; Biorhythms program.

## August 1979

**Reviews:** Pet II KIM, Pros and Cost of PASCAL Microcomputer user groups; Designing a small business application Part 3; Interfacing Pet with a mainframe Part 2; Life game program.

## September 1979 \*

**Reviews:** Powerhouse 2, Acord Anadex and Heathkit printers Artificial intelligence; Build your own joystick; Computer scene in the North West; Mathematics on a Pet; Self-teaching games program.

## October 1979

**Reviews:** Desys 3000, Pet, Apple II and Tandy 2000; Electronic scoreboard; Inside Speak 6000; Introduction to LISP; Inside Protel.

## November 1979

**Reviews:** Ray II, and PCS Teletext computer; Public for the radio amateur; Learning programs; The self-testing chip; Financial modelling.



September 1979



April 1980



July 1980



August 1980



September 1980



October 1980

## December 1979

**Reviews:** Transam Tutor, Tutor and ITT 2020, Compuserve, Heli, Heli, Heli set up computer store; Heli, Heli, Heli users. File handling techniques.

## January 1980

**Reviews:** Hewlett Packard HP-41C systems Eurapple — What's new in 1980 Computer graphics. Using a micro to measure pain responses. Getting started with micros.

## February 1980

**Reviews:** Minimax Add-on machine code chip for Pet. Video Genie. Personal computer networks; Multi-user electronics and miniaturisation; A simulated battle game; Mugs; Business education; Robotics Part 1; Commodore printer; Micro in antique business; How to write better programs; High speed stepper motors and the Pet.

## March 1980

**Reviews:** Tandy TRS-80 model II. MSI System 7; Training schemes for programmers; Copyright Law and software; Computer date program; Sheppard's; Chess page celebration of chess playing; Assembly language part 1, machine code; Hardware Buyers' Guide.

## April 1980

**Reviews:** Nascom single-board. Superbrain. Commodore database; Memory made for this, latest techniques in data storage. How to raise cash for your micro business; Eight Basics for Nascom; A video link for London; Software Buyers' Guide.

## May 1980

**Reviews:** Z-Plus. UK-101; Intelligent gambling, how the micro might forecast sports results; Videotex and the micro; Good software is expensive; Color display language part 3; New monthly column — 6502 Special; COS for Apple II. Hardware Buyers' Guide.

## June 1980 \*

**Reviews:** Panasonic JD-700U. VisiCalc. The electronic newsagent, newstrade applications; Latest developments in viewdata systems; Social services and micro applications; Electric motors as computer-controlled servo mechanisms; New monthly column — Sorcerer's Apprentice; COS for Apple II part 2. Software Buyers' Guide.

## July 1980

**Reviews:** Sharp PC-1211; Sinclair Z-80; Payroll-200; Tuscan designer's story — Birth of a system. Part 1. Apple II and the micro. The story of a micro game; CPM room computer; Cup; A game; CPM explained; Chess and copy for Nascom I; Hardware Buyers' Guide.

## August 1980

**Reviews:** Texas Instruments TI99/4; Rair, hard-disc system; Computech sales ledger; Tuscan designer's story part two; Games; Adventure II and Supertank part two; a listing of user groups; MUSE software standards. This and much more including the Software Buyers' Guide.

## September 1980

**Reviews:** Motorola Exorset; Ohio Scientific Challenger; Anagram stock control; Tuscan design story Part III; Personal money management; Naspen word processor; Shape table compiler for Apple II and ITT2020 Special Peripherals Buyers' Guide.

## October 1980

**Reviews:** SuperPet; Vector Graphic MZ System B; Desktop Plan. U.S. Presidential Election Game. Tuscan designer's story, part four. Computer education, Junior Minister interviewed. Chess Game Survey. Winchester technology. Statistics on a micro.

Fill in the coupon opposite and return it with your remittance to *Practical Computing*, General Sales Dept, Room CP34, Dorset House, Stamford Street, London SE1 9LU. Please note that back issues can be ordered only on the current order form.

\* Limited Stocks

# KINGSTON

## KINGSTON — KRK 1

A hardware repeat key for the PET number/cursor pad — a boon to the busy programmer and the ambitious games programme writer. Aided by the detailed instruction programme the average PET owner can upgrade his machine in a couple of minutes without fear of a fatal 'no-no'. **£17.50**

## KINGSTON — KRK 2

Initially the KRK 2 was conceived as a definitive full keyboard repeat key. However, Kingston ingenuity has optimized on their patented board accessing techniques to allow two invaluable features to be added:

The first, a warm keyboard reset from otherwise fatal crashes. The second, a selectable keyboard tone which allows touch entry at otherwise impossible speeds. We can say with confidence that this unit is an absolute must for any PET user who wants to get the best from his machine. **£35.00**

## KINGSTON — KC 1

A totally new concept in PET's communication with the outside world. At long last the programmer is free from the limitations of the IEEE bus. INPUT, PRINT, LOAD and SAVE to an external RS232 device are now possible without recourse to ingenious/tedious software. A comprehensive on-board firmware package allows all manner of hitherto impossible functions to be achieved including keyboard selectable configuration with full modem control. **£135.00**

## KINGSTON — KC 2

Having achieved one level of impossibilities, we knew someone would need more so here it is —

Simultaneous access to two RS232 serial devices or networks with all the features of the KC 1 and more besides. With this device we give PET users serial RS232 I/O capabilities, which the owners of much more expensive machines would envy. **£150.00**

## KINGSTON — KSB 1

A twenty-way RS232 multiplexing/switching box with 'mind-blowing' potential — Applications of the unit are legion and range from simple networking through multiple disc sharing to multidevice complexes based on a single processor. **£350.00**

## CMC ADA 1200

A low budget IEEE 488/RS232 unidirectional interface, with a proven record of reliability (Field failure rate better than .1 percent). Since the unit is not addressable it is not recommended for use with the Commodore Disc. **£65.00**

## CMC ADA 1400

An addressable IEEE 488/RS232 unidirectional interface, which is proving even more reliable than the ADA 1200 from which it was developed. While it was designed to offer only standard RS232 output it is sufficiently 'beefy' to cope with a number of less demanding current loop applications without modification. **£90.00**

## CMC SADI

SADI — The microprocessor based serial and parallel interface for the Commodore PET. SADI allows you to connect your PET to parallel and serial printers, CRT's, modems, acoustic couplers, hard copy terminals and other computers. The serial and parallel ports are independent allowing the PET to communicate with both peripheral devices simultaneously or one at a time. In addition, the RS232 device can communicate with the parallel device. Special features for the PET interface include:

- Conversion to true ASCII both in and out.
- Cursor controls and function characters specially printed.
- Selectable reversal of upper and lower case.
- PET IEEE connector for daisy chaining.
- Addressable — works with other devices.

Special features for the serial interface include:

- Baud rate selectable from 75 to 192000.
- Half a full duplex.
- 82 character buffer.
- X-ON, X-OFF automatically sent.
- Selectable carriage return delay.

Special features for the parallel interface include:

- Data Strobe — either polarity.
- Device ready — either polarity.

Complete with power supply, PET IEEE cable, RS232 connector, parallel port connector and case. **£175.00**

## CMC AIM 161

A low budget IEEE 488 16-channel analogue to digital convertor for the competent programmer who wants to 'do his own thing'. With a 5-12 volt reference voltage the unit is normally accurate to better than .5%. **£90.00**

## CMC PETSET

An AIM 161 specially configured for plug-in and switch-on use by the less technically graded user. The unit has a number of helpful extras including an input connector board allowing simple screw connection to the outside world. **£135.00**

## CMC APPLESET

Similar to the PETSET, saving that the unit is configured for use with the APPLE. **£135.00**

## CMC TANDYSET

Similar to the PETSET saving that the unit is configured for the TANDY TRS80. **£135.00**

## CMC XPANDR 1

Analogue to digital conversion of up to 128 channels can be achieved by simply connecting as many 16-channel AIM 161 units as you need through this smart board. **£40.00**



## TNW 2000

With over 2,000 units sold, this IEEE 488/RS232 interface can truly be said to be tried and tested. Features include the conversion of both PET and true ASCII, daisy chaining and full address selection.

- Standard RS232.
- Current Loop.

**£135.00**  
**£150.00**

## TNW 3000

A bi-ported, bi-directional IEEE 488/RS232 interface offering everything the discriminating programmer could ask for. Features include independent crystal controlled Baud rate on both ports and fully implemented RS232 with extensive control line options allowing responsive throttling. **£220.00**



## SSM — A10

Two powerful APPLE interface boards in one:

The first an RS232 serial with three handshaking lines (RTS, CTS and DCD), rotary switch selection of nine standard baud rates from 110 to 19200, including 134.5 for selectrics and the modes of serial communication under software control.

The second a double bi-directional parallel with four additional interrupt and handshaking lines, and interface configuration under software control. **£105.00**

## NOTES

- Every Kingston product is carefully burned in and tested before dispatch.
- Kingston's guarantee, warranty and service undertakings are probably the best in the business — If you would like to see what real customer concern is all about, then send for a copy of our standard Guarantee Form!
- All prices quoted by Kingston are inclusive of packaging and shipping, but do not include V.A.T. — Please add 15% V.A.T. to any order.
- We have a number of new and exciting products 'in the pipeline' including:
  - A family of rugged, low budget EPROM programmers and duplicators.
  - A number of new cost effective printers, including daisywheels and single and double pass (better quality) matrix.
  - A low cost TRS expansion.
  - A flexible/expandable industrial control system.
  - Emergency standby power units, ranging from a .5 KVA baby to a 9.5 KVA mainline system.

If you have an interest in any of these items, give us a call. As you might expect from a company which prides itself in being different, we maintain an engineer on call eighteen hours a day, seven days a week to help you.

## KINGSTON COMPUTERS LTD

Scarborough House, Scarborough Road, Bridlington. Telephone 0262 73036



# PETAID

## EVERY PET SHOULD HAVE ONE!



### PETAID EVERY PET SHOULD HAVE ONE!

**PURPOSE:** Provides the complete basic structure for file and screen creation and subsequent Insert, Amend, Delete, Display, Search and Print.

**BENEFITS:** Simple commands, no need for programming knowledge. Create your own screen and file layouts. Files up in hours. Highly structured in Basic. Simple appendment of further basic code for maths and specialised prints, well documented to allow the user to modify the program. Standard variables used, can halve the time for systems development. Common structure for ease of subsequent support. A very powerful STAND ALONE file create and retrieval system. The create file program can be used many times for various files. Further compatible utilities to be available.

**VERSIONS AVAILABLE:** Tape Files £52.95, Sequential Disk £150.65, Random Access Commodore Disk and Computhink 400K £208.15, Computhink 800K £231.15, Indexed Access Method Commodore Disk (Alpha Key Field) £288.65, Extract & Sort on Random Access or IAM Files £87.40.

All prices include V.A.T., Package and Postage.

**PRINTERS SUPPORTED:** Commodore, Anadex, Gume, Teletype 43.

**FEATURES,** The user may:  
Define their own screen and file formats. Multiple disks per file. Very powerful search routine on any field and any content. Up to 50 separate search criteria or multiple simultaneous searches. Unlimited number of fields per record. PETAID programs within same Version are compatible with all PETAID created files of that version. Tape to Disk conversion utility as an extra.

### PACKAGES: ALL PACKAGES REQUIRE: 32K PET, COMMODORE DISK & PRINTER

**INCOMPLETE RECORD SYSTEM** PETAID Based  
Provides user specified Account Numbers, Titles and Final Account formats. Common input for new or carry forward clients. Up to 2300 Nominal Account Numbers. Unlimited transactions.  
Incomplete £750 Final Accounts £350

**BANK & RECONCILIATION** PETAID Based  
Bank Accounting System, automatic facility for standing orders and direct debits. Reminder for charges and interest. 2000 Transactions per Bank Account.  
£100

**ESTATE AGENTS PACKAGE** PETAID Based  
Property and Applicants registers for speedy selection of properties or Applicants. 325 Applicants or Properties per disk.  
£250

**MAILING SYSTEM** PETAID Based  
A complete Mailing Suite, labels, lists, multiple labels. Labels selective based on interest groups, etc. £100

**BOND & PENSION CALCULATIONS**  
Allows the Broker or Agent to use the PET as a selling AID to Demonstrate Bond & Pension and Insurance Quotations.  
£100

**QUOTE PROCESSOR** PETAID Based  
Word Processor in Basic with Mathematics for wordy and complex quotation production. 150 Paragraphs of 1 D lines each with price field per line.  
£120

**GENERAL ACCOUNTING PACKAGE** PETAID Based  
Open item Sales, Purchase, Nominal, Rechargeable Costs, error and status checking (back up forced). One posting routine for all transactions. 4000 Accounts and 18400 live transactions.  
£600

**OTHER PROGRAMS**  
STDCK £100, BLOCK COPY (Bad Blocks Omitted) £25, DIARY PLANNER £100, DDUBLE PRECISION MATHS (M/C Code) £50.

### SOFTWARE SUPPORT SYSTEM

Stage One Software offers a special support and reporting system to enable the users of our Software to get the very best support and advice on how to gain maximum benefit from our packages. Enquiries

will be actioned promptly to provide a first class service which has so far been lacking in the Micro-computer industry.

Adda Computers  
LONDON W5 2NH  
Tel: 01 579 5845

Catlands Computers Ltd  
CHESHIRE  
Tel: 0625 527255

Metyclean Ltd  
LONDON SW1E 5JL  
Tel: 01 828 2511

Sheffield Computer Centre  
SHEFFIELD  
Tel: 0742 53519

R Ward & Son  
GATESHEAD, Tyne & Wear  
Tel: 0532 605915

Advanced Management Systems Ltd  
LONDON EC2Y 9AA  
Tel: 01 538 9319  
01 506 4975

O.A.M's Office Equipment Ltd  
LIVERPOOL  
Tel: 051 227 3301

Microvare Computers Ltd  
HULL HU4 6SB  
Tel: 0482 5627107

Slough Microshop  
SLOUGH  
Tel: 0753 72470

Walters Computers Systems Ltd  
STOURBRIDGE, W Midlands  
Tel: 0562 885937

Alpha Business Systems  
HERTFORD  
Tel: 0992 57423

G M Marketing  
ANDOVER, Hants  
Tel: 028 471 410

Milequip Ltd  
GLOUCESTERSHIRE  
Tel: 059 451 624

Software Development Services Ltd  
DUBLIN 4  
Tel: Dublin 885755

Microputers Ltd  
KENDAL, Cumbria  
Tel: 098 62 4101

Amplicon Micro Systems Ltd  
BRIGHTON  
Tel: 0273 562613

JAD Integrated Services Ltd  
PLYMOUTH  
Tel: 0752 62615

M.M.S  
BEOFORD  
Tel: 0234 40602

Tekdata  
STOKE ON TRENT ST6 4PA  
Tel: 0782 813831

T & V Johnson (Microcomputers)  
CAMBERLEY, Surrey  
Tel: 0276 62506

Business Electronics  
SOUTHAMPTON  
Tel: 0703 738248

Jeffrey Martin Computer Services Ltd  
NEWQUAY  
Tel: 063 73 2863

R.P.L. Microsystems  
DOUGLAS, I.O.M.  
Tel: 0624 4247

Thistle Computers  
ORKNEY KW15 1HQ  
Tel: 0856 3140

Melard Services (Fyde) Ltd  
POULTON LE FYLDE, Lancs  
Tel: 0253 823654

RUF Computers (UK) Ltd  
BURGESS HILL, Sussex  
Tel: 04446 45211

**MAIL ORDER** Written orders with cheque or Access/Visa No. to:

**STAGE ONE SOFTWARE** 6 Criterion Arcade, Old Christchurch Road, Bournemouth. 23570



Please supply: ITEM ..... QUANTITY .....

AMOUNT £ ..... CHEQUE NO. ....

Name .....

Address ..... ACCESS/VISA NO. ....

# CP/M COMPATIBLE SOFTWARE FROM SUPERSOFT

## System Maintenance

Diagnostics 1 — easily the most comprehensive set of CP/M compatible system check-out programs ever assembled. Finds hardware errors in your system, confirms suspicions or gives the green light. Tests:

- \* MEMORY
- \* CPU (8080/8085/Z80)
- \* TERMINAL
- \* DISK
- \* PRINTER

The CPU test is the first of its kind to our knowledge. It pays to find problems before they become serious. Minimal requirements 24K CP/11. Supplied complete with User Manual £39.95, manual alone £9.95.

## Software Security

Encode/Decode is a complete software security system for CP/M, a sophisticated coding program package which transforms data stored on disk into completely unrecognisable coded text. Encode/Decode supports multiple security levels and passwords, and a user defined combination (from the billion possible) is used to code and decode a file. Uses are unlimited, and DATA BASES, PAYROLL FILES, PROGRAMS, GENERAL LEDGER, CORRESPONDENCE, TAX RECORDS, INVENTORY, ACCOUNTS PAY/REC and MAILING LISTS are just a few of the applications possible. Encode/Decode I provides a level of security for normal use. £39.95 complete with User Manual. Manual alone £9.95. Encode/Decode II provides enhanced security for the most demanding needs. £79.95 complete with User Manual. Manual alone £9.95. Both versions come supplied on discette.

## MICROCHIPS AT MICRO PRICES!

### LOW PROFILE SOCKETS BY TEXAS SAGE

8 pin	7p	18 pin	15p	24 pin	22p
14 pin	9p	20 pin	18p	28 pin	28p
16 pin	10p	22 pin	22p	40 pin	28p

<b>DIL SWITCHES</b>	74LS151	75p	75325	325p
4 pole	74LS153	75p	75361	350p
6 pole	74LS155	65p	75365	295p
8 pole	74LS161	78p	75451	50p
10 pole	74LS163	90p	75491/2	75p
	74LS164	90p	8126	175p
	74LS168	190p	8128	175p
	74LS174	99p	8195	175p
	74LS175	99p	8197	175p
<b>74LS</b>	74LS195	87p		
74LS00	74LS221	110p		
74LS01	74LS244	175p		
74LS04	74LS245	325p		
74LS08	74LS251	120p		
74LS10	74LS257	110p		
74LS11	74LS290	95p		
74LS12	74LS293	120p		
74LS14	74LS366	57p		
74LS15	74LS373	170p		
74LS20	74LS374	170p		
74LS30	74LS375	140p		
74LS32	74LS377	188p		
74LS40	74LS393	135p		
74LS42	74LS490	140p		
74LS47	74LS670	260p		
74LS48				
74LS49				

<b>74LS73</b>	30p	<b>INTERFACE</b>		
74LS74	30p	<b>LINEAR</b>		
74LS75	39p	MC1488	90p	
74LS86	39p	MC1489	90p	
74LS90	40p	DM8123	125p	MC 144 12VL
74LS107	40p	75150	125p	Z80 P10
74LS123	69p	75154	125p	Z80 CTC
74LS125	50p	75182	195p	Z80A P10
74LS132	79p	75322	250p	Z80A CTC
74LS138	69p	75324	325p	Z80 DMA

Z80A DMA	2495p
Z80 S10/1	2995p
Z80A S10/0	3495p
Z80 S10/1	2995p
Z80A S10/1	3495p
Z80 S10/2	2995p
Z80A S10/2	3495p

<b>KEYBOARD ENCODER</b>	
AY-5-2376	795p
<b>UARTS</b>	
AY-5-1013A	325p
AY-3-1015D	398p
IM6402 IPL	425p

<b>CHARACTER GENERATOR</b>	
RO-3-2513 UC	450p

<b>DEVELOPMENT MODULE</b>	
Z8000 DM	£1099

<b>BIPOLAR PROMS</b>	
93448 518 x 8 40 NS	p.o.a.
93453 1k x 4 40 NS	p.o.a.
93451 1k x 8 45 NS	p.o.a.
93511 2k x 8 50 NS	p.o.a.

<b>FLOPPY DISK CONTROLLERS</b>	
FD1771 B-01 S/D Inverted Bus	2995p
FD1791 B-01 D/D Inverted Bus	4995p
FD1792 B-01 S/D Inverted Bus	3495p
FD1793 B-01 D/D True Bus	5495p
FD1794 B-01 S/D True Bus	3495p
FD1795 B D/D Inverted Bus, side select	5995p
FD1797 B D/D True Bus, side select	5995p

<b>MEMORIES</b>	
2114 300 NS	275p
4116 200 NS	300p
4116 150 NS	395p
4315 (4k x 1) CMOS	395p
RAM 450 NS	995p
6514 (1k x 4) CMOS	695p
RAM 450 NS	695p

<b>EPROMS</b>	
1702A	450p
2708 450 NS	425p
2716 5V 450 NS	800p
253232K 450NS	2995p

<b>CPU'S</b>	
8502	795p
6504	795p
6505	795p
6800	695p
6802	995p
8080A	525p
8085A	1095p
Z80	795p
Z80A	995p
Z8001	12500p
X8002	9500p
WD9000B	19900p

**THE NEW GI COMPUTER SOUND CHIP**  
The amazing AY-3-8910 is a fantastically powerful sound and music generator, perfect for use with any 8-bit micro processor. Contains 3 tone channels, noise generator, 3 channels of amplitude controls, 16-bit envelope period control, 2 parallel I/O, 3D/A converters plus much more. All in 40 pin DIP. Super easy to interface to the S-100 or other Busses. ONLY £8.50 + VAT, including FREE reprint of BYTE '79 article! Also, add £2.25 for 60 page data manual. "Perhaps the next famous composer will not direct a 150 piece orchestra but, rather, a trio of micro-computers controlling a bank of AY-3-8910s." BYTE July '79.

**NEW! STEREO S100 SOUND COMPUTER BOARD!**  
At last, an S-100 Board that unleashes the full power of two unbelievable General Instruments AY-3-8910 NMOS Computer sound IC's. Allows you under total computer control to generate an infinite number of special sound effects for games or any other program. Sounds can be called in BASIC, ASSEMBLY LANGUAGE etc.  
**KIT FEATURES**  
\*Two GI Sound computer IC's (AY-3-8910)  
\*Four parallel I/O ports on Board  
\*Uses on Board audio Amps or your STEREO  
\*On Board proto typing area  
\*All sockets, parts and hardware are included  
\*PC Board is soldermasked, silk screened with gold contacts  
\*Easy, quick and fun to build, with full instructions  
\*Uses Programmed I/O for maximum system flexibility  
\*Both BASIC and ASSEMBLY language programming examples are included  
**COMPLETE KIT ... ONLY £59.96** includes 60 page data Manual

**BARE BOARD ... ONLY £25.00** includes 60 page data Manual  
**AY-3-8910 chip special price** with purchase of **BARE BOARD (2 chips) £15.00**

**SOFTWARE**  
SCL is now available! Our Sound Command Language makes writing Sound Effects programs a SNAP! SCL also includes routines for Register-Examine-Modify, Memory-Examine-Modify and Play-Memory. SCL is available on CP/M compatible diskette or Z80/2716. Diskette — £19.95, Z80 — £14.95, 2716 — £24.95. Diskette includes the source. EPROM'S are ORG at E000H.

ONLY £7.95! (8 for £50)  
The TIC 5514P from Toshiba, CMOS equivalent of the 2114!  
\* Lower Power Dissipation  
\* 10pW/BIT (TYP.) at 3.0V (STANDBY)  
\* 10uW/BIT (TYP.) at 5.0V (OPERATING)  
\* Data Retention Voltage 2V to 5.5V  
\* Single 5V Power Supply  
\* 18 PIN Plastic Package  
\* Full Static Operation  
\* Three State Output  
\* Input/Output TTL Compatible  
\* Fast Access Time 450NS.

Toshiba's TC5514P (industry type 6514) is a full static read write memory organised as 1024 words by 4 bits using CMOS technology. Ultra low power dissipation means it can be used as battery-operated portable memory system and also as a non-volatile memory with battery back-up. Operates from a single 5V power supply with static operation, hence no refresh periods and a much simplified power supply circuit design. Three state outputs simplify memory expansion for minimum data retention voltage is 2V, the battery back-up system needs only simple circuit. Toshiba's original CMOS technology also means wide operating and noise margins. The TC 5514P is moulded in a dual-in-line 18 pin plastic package 0.3 inch in width.

Ordering information. Unless otherwise stated, for orders under £50 add 50p p&P. Add 15% VAT to total (no VAT on books). All devices are brand new, factory prime and full spec and subject to prior sales and availability. Prices subject to change without notice. Minimum telephone order using ACCESS is £10. If ordering by post with ACCESS, include name, address and card no. written clearly. Please allow 4/6 weeks delivery on books.

Unit 9/10, 1st Floor, E Block, Dept. PC3  
38 Mount Pleasant, London WC1X 0AP  
Tel: 01-278 7369  
Telex: 895 3084



## BOOKS

Please order books by reference no. and title, and add 50p post & packing for each book ordered.

21168 Active Filter Cookbook	£10.95
21440 Aviation Electronics 3rd Ed.	£ 6.75
21558 Audio IC Op Amp Applications 2nd Ed.	£ 5.95
21596 Basic Programming Primer	£ 6.50
21554 Boolean Algebra for Computer Logic	£ 4.50
21447 The 8080A Bugbook-Microcomputer Interfacing & Programming	£ 7.75
21465 Building & Installing Electronic Intrusion Alarms	£ 3.95
21524 The Cheap Video Cookbook	£ 4.50
21398 CMOS Cookbook	£ 7.75
21652 Computer Dictionary 3rd Ed.	£ 8.95
21650 Computer Graphics Primer NEW!	£ 7.50
21693 Computers & Programming Guides for Scientists & Engineers 3rd Ed. NEW	£11.95
21697 8085A Cookbook NEW!	£ 7.50
21539 Design of Active Filters with Experiments	£ 5.95
21536 DEBUG: An 8080 Interpretive Debugger	£ 3.75
21537 Design of Op Amp Circuits with Experiments	£ 5.95
21545 The Design of Phased-Locked Loop Circuits with Experiments	£ 6.75
21686 Design of VMOS Circuits with Experiments NEW!	£ 5.95
21618 Electronic Telephone Projects	£ 4.95
21351 How to Buy and Use Minicomputers and Microcomputers	£ 7.50
21684 How to program and interface the 6800 NEW!	£10.50
21459 How to Program Microcomputers	£ 6.75
21127 How to Read Schematic Diagrams 3rd Ed.	£ 4.25
21613 How to Use Integrated Circuits Logic Elements 3rd Ed.	£ 4.50
21634 HWS Crash Course in Microcomputers NEW!	£13.25
21527 IC Converter Cookbook	£10.50
21695 IC Op Amp Cookbook 2nd Ed.	£11.25
21416 IC Timer Cookbook	£ 8.50
21546 Interfacing & Scientific Data Communications and Experiments	£ 4.50
21550 Introductory Experiments in Digital Electronics and 8080A Microcomputer Programming and Interfacing, Book 1	£ 9.95.
21551 Introductory Experiments in Digital Electronics and 8080A Microcomputer Programming and Interfacing, Book 2	£ 8.25

21601 Instrumentation: Transducers and Applications	£ 8.95
21452 Learn Electronics Thru Troubleshooting 2nd Ed.	£ 8.25
21694 LC Circuits	£ 4.46
21542 Logic and Memory Experiments Using TTL Integrated Circuits — Book 1	£ 7.50
21543 Logic and Memory Experiments Using TTL Integrated Circuits — Book 2	£ 7.50
21568 Linear IC Principles, Experiments and Projects 2nd Ed.	£ 7.50
21540 Microcomputer-Analog Converter Software and Hardware Interfacing	£ 7.25
21583 Microcomputer for Business Applications	£ 6.75
21614 Microcomputer Interfacing with the 8255 PPI Chip	£ 6.75
21653 Microcomputer Primer 2nd Ed.	£ 8.95
21612 Oscilloscope. Applications & Experiments	£ 6.75
21635 99 Practical Electronics Project 2nd Ed.	£ 3.75
21599 Practical Low-Cost IC Projects 2nd Ed.	£ 3.50
21557 Practical RF Communication Data for Engineers and Technicians	£ 6.75
21651 Programming and Interfacing the 6502	£10.50
21482 Regulated Power Supplies 2nd Ed.	£ 7.50
21419 Security Electronics 2nd Ed.	£ 4.50
21541 8080/8085 Software Design	£ 7.25
21615 8080/8085 Software Design — Book 2	£ 7.50
21656 6502 Software Design	£ 7.50
21621 Solar Heating	£ 5.25
21587 The S-100 and Other Microbuses	£ 4.50
21628 TEA: An 8080/8085 Co-Resident Editor/Assembler	£ 6.75
21538 The 555 Timer Applications Source-Book with Experiments	£ 4.50
21633 TRS-80 Interfacing	£ 6.75
21035 TTL Cookbook	£ 7.25
21103 Troubleshooting with the Oscilloscope 3rd Ed.	£ 4.50
21313 TV Typewriter Cookbook	£ 7.50
21339 Video Security Systems	£ 5.25
21521 Video Tape Recorders	£ 7.50
21682 Z80 Microcomputer Design Projects	£ 9.75
21609 Z80 Microprocessor Programming and Interfacing — Book 1	£ 8.25
21610 Z80 Microprocessor Programming and Interfacing — Book 2	£ 9.75



PET 2001



from £425

TR 80



from £365

From Radio Shack Corp.

APPLE II

from £695



authorised dealers

SORCEROR

from £730



authorised dealers

ADVANCED SYSTEMS



# MICROCOMPUTERS ETC

For Hardware, Software, Peripherals, Consultancy and Competitive Prices.

Registered business name



PET 2001-8 (PET with 8K memory)

£425.00

Integral cassette

PET 3008 (8K) with large keyboard

£450.00

PET C2M External Cassette Deck

£53.00

ACCESSORIES

IEEE 448/Centronics type parallel

Interface

£35.00

IEEE to Pet Cable

£19.00

IEEE to IEEE cable

£24.00

PETSET 1 16 Channel AD Converter

£166.00

c.w. all interfacing requirements

£166.00

BASIC SYSTEMS

TRS 80, 4K Level II (as above with

Keyboard with 4K memory, Video

Unit, Cassette Drive and 240v

power supply unit)

£499.00

TRS 80, 16K RAM

£275.00

TRS 80, Expansion Interface with

Level II Basic)

£360.00

ACCESSORIES

Radio Shack Phone Modem

£160.00

UHF Modulators (encased with

leads for 625 lines)

£20.00

RAM upgrade (4-16K, 16-32K,

32-48K) supplied and fitted at our

premises (Kit £80.00)

£95.00

TRS80 CPU 2 speed mod.

£25.00

and fitted

£49.00

BASIC SYSTEM

Apple II Plus computer - (16K RAM) - video output

£695

ACCESSORIES

Real time clock/Calendar card -

£14.00

1/1000 sec to 388 days with

interrupt, software controllable

£128.00

Speechlab - provides voice control

for the Apple

£160

Supertalker - adds human speech

output!

£113.00

ALF Music Synthesizer Card

£138.00

A1-02 Data Acquisition Card

£180.00

Graphics Tablet

£462.00

AC Line Controller

£270.00

RAM Upgrade (16-32K, 32-48K)

£69.00

Hobby Prototype Card

£20.00

ROMplus - u.l.c. mixed text/graphic

£105.00

BASIC SYSTEMS

Sorcerer (inc. UHF Modulator)

£795.00

ACCESSORIES

Easy Video Unit

£240.00

Easy Video Monitor

£240.00

CPM on Disk

£145.00

ADVANCED SYSTEMS

TRS 80 Model II with integral B" floppy

£2,300

Expandable up to 3 Megabytes Disk Storage (Available for demonstration - by appointment only)

£695

SUPERPETSYSTEM - CBM6302 Computer with 30 col. screen

£895

CBM8050 - Dual Disk Drive giving 950K User Storage

£895

PET BUSINESS SYSTEM

Special Offer!

CBM 3032 Micro

computer, CBM 3040 Dual Disk Drive, CBM 3032

Tractor Floppy Printer and all cables

£1799.00

TVJ MICRO EXHIBITION

5th JOHNSON HOUSE

Cambridge, CB2 3RQ

We are holding a Special Exhibition at our new

prestigious showroom:-

Continuous demonstrations of Business Systems

Future directions of the Microcomputer Systems

Many Stock Items at Sale Prices

## BASIC SYSTEMS

PET 2001-8 (PET with 8K memory)

£425.00

Integral cassette

PET 3008 (8K) with large keyboard

£450.00

PET C2M External Cassette Deck

£53.00

ACCESSORIES

IEEE 448/Centronics type parallel

Interface

£35.00

IEEE to Pet Cable

£19.00

IEEE to IEEE cable

£24.00

PETSET 1 16 Channel AD Converter

£166.00

c.w. all interfacing requirements

£166.00

BASIC SYSTEMS

TRS 80, 4K Level II (as above with

Keyboard with 4K memory, Video

Unit, Cassette Drive and 240v

power supply unit)

£499.00

TRS 80, 16K RAM

£275.00

TRS 80, Expansion Interface with

Level II Basic)

£360.00

ACCESSORIES

Radio Shack Phone Modem

£160.00

UHF Modulators (encased with

leads for 625 lines)

£20.00

RAM upgrade (4-16K, 16-32K,

32-48K) supplied and fitted at our

premises (Kit £80.00)

£95.00

TRS80 CPU 2 speed mod.

£25.00

and fitted

£49.00

BASIC SYSTEM

Apple II Plus computer - (16K RAM) - video output

£695

ACCESSORIES

Real time clock/Calendar card -

£14.00

1/1000 sec to 388 days with

interrupt, software controllable

£128.00

Speechlab - provides voice control

for the Apple

£160

Supertalker - adds human speech

output!

£113.00

ALF Music Synthesizer Card

£138.00

A1-02 Data Acquisition Card

£180.00

Graphics Tablet

£462.00

AC Line Controller

£270.00

RAM Upgrade (16-32K, 32-48K)

£69.00

Hobby Prototype Card

£20.00

ROMplus - u.l.c. mixed text/graphic

£105.00

BASIC SYSTEMS

Sorcerer (inc. UHF Modulator)

£795.00

ACCESSORIES

Easy Video Unit

£240.00

Easy Video Monitor

£240.00

CPM on Disk

£145.00

ADVANCED SYSTEMS

TRS 80 Model II with integral B" floppy

£2,300

Expandable up to 3 Megabytes Disk Storage (Available for demonstration - by appointment only)

£695

SUPERPETSYSTEM - CBM6302 Computer with 30 col. screen

£895

CBM8050 - Dual Disk Drive giving 950K User Storage

£895

PET BUSINESS SYSTEM

Special Offer!

CBM 3032 Micro

computer, CBM 3040 Dual Disk Drive, CBM 3032

Tractor Floppy Printer and all cables

£1799.00

TVJ MICRO EXHIBITION

5th JOHNSON HOUSE

Cambridge, CB2 3RQ

We are holding a Special Exhibition at our new

prestigious showroom:-

Continuous demonstrations of Business Systems

Future directions of the Microcomputer Systems

Many Stock Items at Sale Prices

## DISKS

PET 3040 (dual drive) 303K User storage

\* £695.00

16K disk drive/400K

storage

£895.00

CompuLink (dual drive) 800K storage

£1145.00

TR 80

Shugart drive

£289

Percom FD200 drive 110v

£275

Microplus Dual Drive (394K storage)

£395.00

Apple Hard Disk (11Mb)

£350.00

APPLE Drive - 118K storage, 1st drive

£349.00

Apple Drive - 118K storage, 2nd drive

£399.00

CONVUS Hard Disk (11Mb)

£350.00

SORCEROR

Easy - 315K Storage (394K storage)

£680

Convus Hard Disk (11Mb)

£1500.00

PRINTERS

PET 3022 80 col with PET graphics

£435.00

Tractor feed)

\* £435.00

TR 80 Screen Printer (text

and graphics) (110x)

£345.00

New Radio Shack Micro Printer

£1245.00

GENERAL

# SIRTON COMPUTERS



76 Godstone Road, Kenley (Nr Croydon) Surrey CR2 5AA  
Tel: 01-668 0761/2

## MIDAS S.100 SYSTEMS

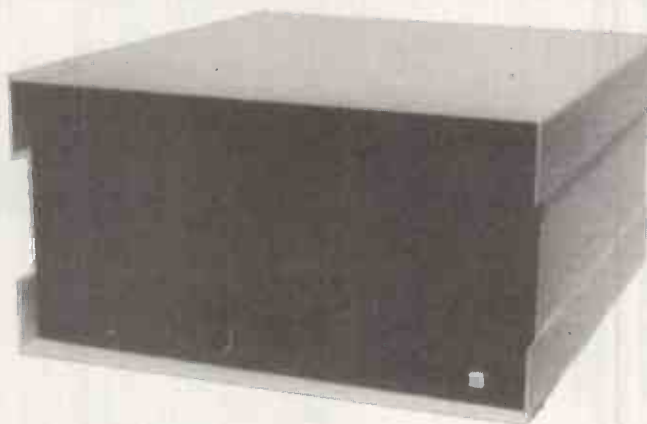

**MIDAS 1: From £750**  
**MIDAS 2: From £1580**  
**MIDAS 3: From £2150**  
**MIDAS 4: From £5900**  
**ITHACA-DPS 1: From £1075**

- Our versatile Z80 Microcomputers are available as standard units or custom configured to your exact specification from a comprehensive range of stocked S100 boards.
- Disc storage capacity of the MIDAS 3 can be 2M Bytes, expandable to over 20M Bytes with a Winchester Hard Disc Unit in our MIDAS 4 range.
- MIDAS runs CP/M and MP/M is also available. Other Software includes M-BASIC, C-BASIC, FORTRAN, COBOL, CIS-COBOL, PASCAL and Word Processing.
- **A MIDAS 3, with 64K RAM and 2M Bytes storage on two 8" drives with two Serial I/O Ports and CP/M 2 only £2600.**
- Printers, VDUs and other peripherals stocked to give complete package systems at keen prices.
- Business Packages include Accounts, Stock Control, Purchase Ledger etc etc.
- OEM and Dealer enquiries welcome.

Boards stocked from Ithaca, Godbout, SSM, S D Systems, Vector, Micromation, Mullen, Mountain Hardware, Hi-Tech, Video Vector, Pickles & Trout, Central Data, Cromemco, Thinker Toys — Send for full Price List (many available in kit form).

<b>Processor</b>		<b>RAM</b>	
Z80 Starter Kit	£188	Dynamic RAM 16K-64K	from £205
SBC100	£208	Static RAM 8K-64K	from £95
SBC200	£237	Memory Manager	£52
Z80 CPU 4 MHz	from £130	<b>I/O</b>	
<b>EPROM</b>		2S/4P prov 4K RAM/4K ROM	£169
2708 EPROM (16K)	£60	2S/2P or 2S/4P or 3P/1S or 4S/2P	from £135
2708/2716 Programmer	from £134	Analogue 8 or 12 bit	from £287
<b>Video</b>		Optically isolated I/O	£114
16 lines, 32/64 ch	from £104	IEEE 488 Interface	£350
24 lines, 84 ch	from £265	<b>Miscellaneous</b>	
<b>Disc Controllers</b>		Real Time Clock	£180
Versafloppy S/D	£198	High Dens Graph/8K RAM	£333
Doubler D/D	£280	Hi-Tech Colour	£295
		Motherboards — various from	£34
		Extender Board/logic probe	£39
		Maths Board AMD 9511	£330

**Software**  
 CP/M 1 & 2, MP/M, PL/1, C-BASIC 2, M-BASIC V5, XYBASIC, FORTRAN 80, COBOL 80, CIS-COBOL, PASCAL/Z, PASCAL (UCSD), PASCAL M/T, Forth, MAC, ZSID, Disassembler, Wordstar, Datastar, Magic Wand, Wordmaster, Supersort etc etc.

**WRITE OR PHONE FOR CATALOGUE**  
**SIRTON COMPUTERS WAS FORMERLY SIRTON PRODUCTS**



# BIRMINGHAM COMPUTER CENTRE

COMPLETE BUSINESS SYSTEMS FROM THE PROFESSIONALS

## 3000 SERIES

8K with built-in cassette  
 8K with professional keyboard  
 16K with professional keyboard  
 32K with professional keyboard  
 343K Twin Floppy Disk  
 CN2 Cassette Deck  
 IEEE Cables — Pet  
 IEEE to IEEE  
 Tractor Feed Printer

£  
 425  
 450  
 550  
 695  
 £695  
 55  
 20  
 25  
 425

## COMMODORE OFFICIAL DISTRIBUTOR



32K SYSTEM COMPLETE £1850

## NEW 8000 SERIES

8032 — 32K with 80 col Screen  
 8050 — Twin Disk Drive 950K

£  
 895  
 895



Latest Apple II  
 with Auto-Start Rom  
 and Floating Point  
 Basic.

48K + Disk Drive  
 with Controller.



£1044  
 + VAT

**NEW MODEL: BD-80P**  
**THE NUMBER 1 HI-SPEED PROFESSIONAL**  
**MATRIX PRINTER.**

Now with graphics plus 10 user  
 defined 750K Buffer Standard  
 with further 2K option  
 RS232  
 Serial,  
 or parallel interface  
 plus numerous advanced  
 features.

£  
 695  
 349  
 299  
 69  
 299  
 110  
 69  
 115

Full Range of Software Available

## SHARP MZ 80K



48K £550  
 + VAT

A complete Personal Computer System.  
 At an Economical Price

£

20K 480 Hi-resolution monitor.  
 32K 529 Fast cassette unit.  
 36K 549 Extensive graphics plus  
 Built in sound GEN.

48K 599

Widely accepted as the most powerful  
 8-bit cpu on the market.  
 Floppy disk drive now available plus  
 printer.

## THE ULTIMATE IN DAISYWHEEL PRINTERS

### RICOH.RP 1600



£475

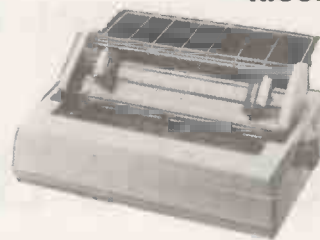

£1490

THE BEST WORDPROCESSOR. PRINTER. AVAILABLE  
 DEALER ENQUIRIES WELCOME

NEW-LOW—PRICE

## IF IT'S THE BEST WE STOCK IT

Complete range of — Off the Shelf Programs from the best in  
 the country including:  
 Commodore — Full range of Business Programs.  
 Act — Complete range available  
 Bristol Software Factory. Trader-Item-Monitor  
 Computastore — Payroll  
 Gramma-Winter — Complete Suit of Programs

Full range of Books and Magazines  
 C15 — Super Quality Data Tapes Boxed 10 — £5.00  
 Disks certified 5 1/4' Boxed 10 — £30.00  
 Printer Ribbons — Listing Paper — Mailing Labels —  
 Dust Covers, etc.  
 Commodore 3032/16. Disk operating systems in  
 ROM.

\* SPECIAL PRICES FOR BETSI — KIMSI — MOTHERBOARDS — KIM.1. — PHONE FOR PRICE \*

SHOWROOMS OPEN DAILY. 9—6 P.M.  
 LARGE CARPARK ADJACENT.

DEMONSTRATIONS AT YOUR CONVENIENCE.  
 SALES • SERVICE • SATISFACTION



**CAMDEN ELECTRONICS**  
 462 COVENTRY ROAD  
 SMALL HEATH, BIRMINGHAM B10  
 021-773 8240 — 021-772 5718

HP  
 LEASING  
 ETC

• Circle No. 293

# DOLPHIN PRINTERS

From WALTERS MICROSYSTEMS — Britain's leading manufacturer.

## Introducing the advanced BD 136 printing at 240 characters per second

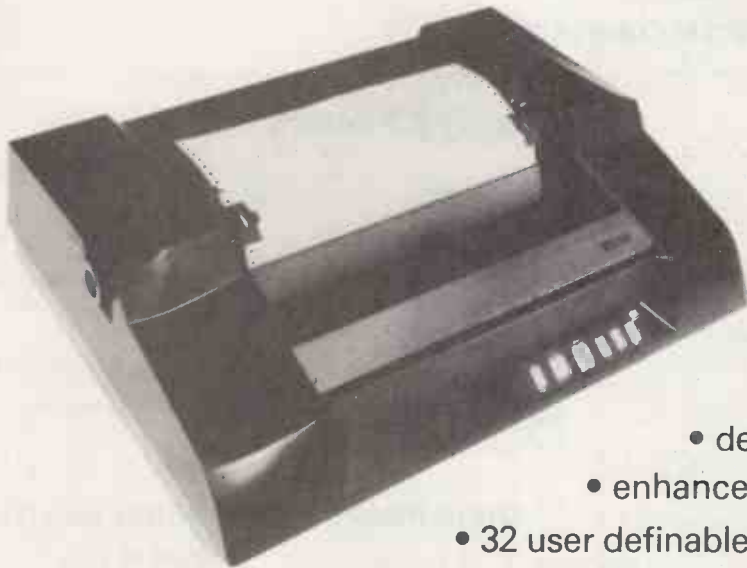

- large 100 line buffer
- centre & right justification
- decimal tab alignment
- enhanced characters
- 32 user definable characters
- £1200.00 end user

## & also the BD 80P

- 125 characters per second
- 80/132 characters per line
- 64 graphic characters
- 10 user definable characters
- 750 character buffer standard
- complete with RS 232C, IEEE or parallel interfaces
- £500.00 end user

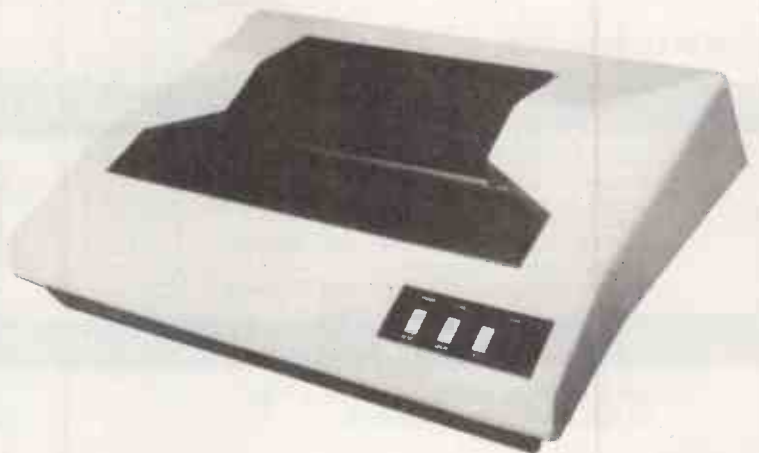

For further information contact the Sales Office  
Walters Microsystems,  
1, Blenheim Road, Cressex,  
High Wycombe,  
Buckinghamshire.  
Tel (0494) 445172 Telex 837600

• Circle No. 294

# interface components

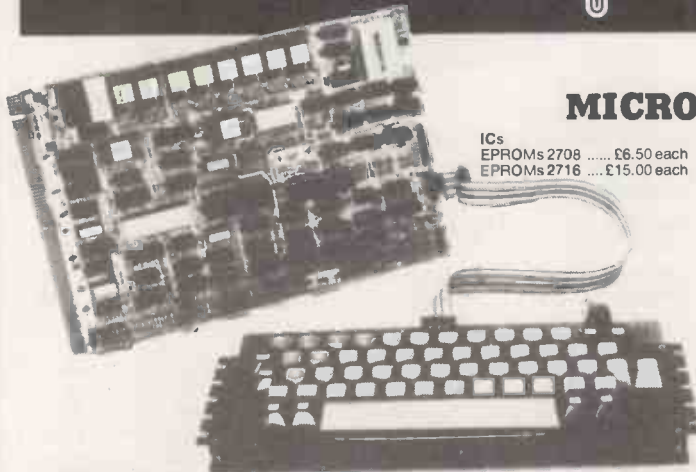

## MICRO MART

ICs  
EPROMs 2708 ..... £6.50 each  
EPROMs 2716 ..... £15.00 each

MEMORIES  
21L02 ..... £0.80 each  
4027 ..... £1.99 each  
4116 ..... £4.50 each  
2114 ..... £3.00 each

Z80 DEVICES  
MK3880 ..... £9.50 each  
MK3881 (P10) ..... £6.25 each  
MK3882 (CTC) ..... £6.25 each

VOLTAGE REGULATORS  
7805 ..... 80p each  
7812 ..... 80p each  
7815 ..... 80p each  
7824 ..... 80p each  
7905 ..... 105p each  
7912 ..... 105p each  
7915 ..... 105p each  
7918 ..... 105p each  
7924 ..... 105p each  
Add VAT and 30p P&P to all orders

## SHARP'S DESK-TOP BRAIN. MZ-80K FROM £480 Plus VAT

An amazing Z-80 controlled personal computer supplied with 78-key ASCII keyboard; 14K extended BASIC; VDU (40 characters x 25 lines); fast cassette facility; 4K monitor ROM; 80 x 50HR Graphics; and a choice of 20K, 32K or 48K of internal random access memory.

A 50-pin universal BUS connector allows the addition of printer, floppy discs, etc. There is also a built-in 3-octave music function.

20K System ..... £480 + VAT  
32K System ..... £529 + VAT  
MZ80FD (twin floppies with 208K) ..... £780 + VAT  
MZ80P3 Printer ..... £517 + VAT  
MZ80 I/O Interface ..... £99 + VAT  
Stock control & Sales/Purchase ledger software now available.

## NASCOM-2

MEMORY ● 8K Microsoft BASIC ● 2K NAS-SYS 1 monitor ● 1K Video RAM ● 1K Workspace/User RAM ● On-board 8 sockets provided for memory expansion using standard 24-pin devices: 2708 EPROMs and MK4118 static RAM. MICROPROCESSOR ● Z80A which will run at 4MHz but is selectable between 2/4 MHz. HARDWARE ● Industrial standard 12" x 8" PCB, through hole plated, masked and screen printed. All bus lines are fully buffered on-board. INTERFACES ● Licon 57 key solid state keyboard (included) ● Monitor/domestic TV interface ● Kansas City cassette interface (300/1200 baud) or RS232/20mA teletype interface.

The Nascom 2 kit is supplied complete with construction article and extensive software manual for the monitor and BASIC.

### EXPANSION OPTIONS

● MK4118 £10 + VAT each  
16K RAM B Board £140 + VAT  
32K RAM B Board £175 + VAT  
48K RAM B Board £210 + VAT  
16K RAM A Board £140 + VAT

**£355**  
Built & tested incl.  
16K Ram A  
+ VAT + £2.50 P&P

## NASCOM IMP PLAIN PAPER PRINTER

The Nascom IMP (Impact Matrix Printer) features:

- 60 lines per minute ● 80 characters per line ● Bi-directional printing ● 10 line print buffer ● Automatic CR/LF ● 96 characters ASCII set (includes upper/lower case, \$, £) ● Accepts 8 1/2" paper (pressure feed) ● Accepts 9 1/2" paper (tractor feed) ● Tractor/pressure feed ● Baud rate from 110 to 9600 ● External signal for optional synchronisation of baud rate ● Serial RS232 interface ● Optional TRS80 interface ● Ribbon cartridge £9.90 + VAT ● 2000 sheets Fan Fold paper £18.00 + VAT.

Nascom Imp  
**£325**  
Plus VAT + P&P £2.99



48K SYSTEM  
SPECIAL OFFER  
OCT/NOV  
**£545**  
+ VAT

## NASCOM-1

12" x 8" PCB carrying 5LSI MOS packages, 16 1K MOS memory packages and 33 TTL packages. There is on-board interface for UHF or unmodulated video and cassette or teletype. The 4K memory block is assigned to the operating system and video display leaving a 1K user RAM. The MPU is the standard Z80 which is capable of executing 158 instructions including all 8080 code. Built price £140 + VAT.

Nascom-1 Kit Price  
**£125** Plus VAT  
+ P&P £1.50



## NEW POCKET COMPUTER FOR UNDER £100 + VAT. SHARP PC-1211

It's true! A real computer that employs the BASIC programming language and fits into a pocket!

The PC-1211 measures only 175mm wide by 70mm deep by 15mm high and weighs a mere 170g (less than 6 ounces) yet look at its features! Up to 1424 program steps, 80 character input line with full editing features, 18 user definable keys, 24 character alpha-numeric LCD display and built-in tone function are included.

An optional cassette interface is available for loading or dumping programs or data. The PC-1211 is battery operated, has an auto power off function, and maintains all programs and data in its memory even after the power has been turned off.

**£91.26**  
Plus VAT + P&P £1.50  
(cassette interface: £13.00 plus VAT + P&P 75p)

## NASCOM FIRMWARE IN EPROM

NASPEN ..... £30.00 + VAT + 30p P&P  
ZEAP 2 ..... £50.00 + VAT + 30p P&P  
NAS-SYS 1 ..... £25.00 + VAT + 30p P&P  
NAS-DIS ..... £37.50 + VAT + 30p P&P  
NAS-DEBUG ..... £15.00 + VAT + 30p P&P  
NAS-SYS 3 ..... £40.00 + VAT + 30p P&P

## NASCOM SOFTWARE ON TAPE

8K BASIC ..... £15.00 + VAT  
ZEAP 2 ..... £30.00 + VAT + 50p P&P

## NASCOM HARDWARE

Motherboard ..... £5.50 + VAT + 50p P&P  
Mini Motherboard ..... £2.90 + VAT + 50p P&P  
3 amp PSU ..... £29.50 + VAT + £1.50 P&P  
VERO DIP board ..... £12.50 + VAT + 50p P&P  
FRAME ..... £32.50 + VAT + £2.00 P&P  
8 Amp PSU Built ..... £105.00 + VAT + £2.75 P&P  
Econographics ..... £30.00 + VAT + 50p P&P  
I/O Board ..... £45.00 + VAT + 50p P&P  
Buffer Board ..... £32.50 + VAT + 50p P&P  
Microtype Model 3 Case ..... £24.50 + VAT + £1.00 P&P

## NASBUS EPROM BOARD

Expands Nascoms 1 & 2 with up to 32K of Eprom. Accepts 2708s or 2716s. Also 24 pin socket for 8K ROM. Wait-state fitted for M2 users. Board can also support Nascom Page Mode Scheme.

**£55** + VAT (Kit)  
**£70** (Built & tested) Plus £1.00 P&P + VAT

Prices correct at time of going to press.

**INTERFACE COMPONENTS LTD.**  
**OAKFIELD CORNER, SYCAMORE ROAD, AMERSHAM, BUCKS HP6 6SU**  
**TELEPHONE: 02403 22307. TELEX 837788**

• Circle No. 295

# Computing on a small budget...

You may have a limited budget, but that's no reason for your system to be limited in its facilities! Mutek offer something better: small systems for *real* computing, with real flexibility, expandability, reliability.

## The superior Superboard...

Our 'superior Superboard' is the *practical* introduction to small computers. Based on Ohio Scientific's popular *Superboard*, our *C1E* extends its features with a larger display and faster running speed. Ready-built in a tough metal case and ready to run, its standard features include the fast full-function Microsoft BASIC; 4K of RAM in which to run programs; a compact machine-code monitor; built-in 53-key keyboard; superbly reliable cassette interface; and a character set of 256 alphabetic, numeric and graphics characters for a 32 line by 48 column video display. More displayable characters than Apple®, Pet® or Tandy's TRS-80®; and more than twice their running speed for BASIC programs, too!

These are the standard features: but expansion in many ways, as shown below, is practical, simple and budget-priced.

## a superior monitor...

CEGMON is a new monitor PROM for all OSI and UK101 BASIC-in-ROM machines — the best thing for OSI systems since OSI itself! Giving those systems the kind of firmware features and flexibility that only appear on machines twice the price or more, it includes:

- **Full screen editing** — more flexible than simple line-editing, CEGMON's twin-cursor screen editor allows you to edit, copy, combine and renumber program lines or text, copying information for BASIC or Assembler from anywhere on the screen.
- **Advanced display features** — all output to the screen can be directed through 'windows' whose position, height and width are all user-definable, and can be changed within programs quickly and easily. Text is printed from the top of the current 'window'. The 'window' format allows free mixing of text and graphics, protected non-scrolling areas and sophisticated use of multiple scrolling and non-scrolling zones; supported by cursor-controls and separate screen- and 'window'-clear commands, this is probably the most flexible screen-handling system available today.

## superior expansion...

The expansion possibilities for the C1E are unusually wide for a budget-priced system. It has an on-board RS-232 serial interface option, for modems or serial printers; a connector for an external keyboard, keypads, joysticks and similar software scanned devices; and a 40-pin expansion socket for connection to a wide range of external boards. The addition of a 610 expansion board and minifloppy drive, for example, converts the C1E to a 32K minifloppy system for little more than £400. With a connector to an OSI-standard 48-line backplane, you can use any of the Ohio Scientific big-system (but budget-priced) boards: high speed data-collection, 16-port serial and 96-line parallel cards, Centronics parallel printer interface, experimental 'breadboard' prototyping board, and many others.

All prices quoted exclude VAT.

We would be delighted to give you further details of our products and services — but please contact us *direct*!

## Mutek — practical computing...for less than you expect

Mutek — the independent Ohio Scientific specialists — Quarry Hill, Box, Wilts. Telephone: Bath (0225) 743289



**C1E (enhanced C1)** ..... £255  
32X48 display, 2MHz operation, 4K RAM; complete with power supply and metal case.

**Superboard E (uncased version of C1E)** ..... £195

Standard (25X25) C1 and Superboard available at £35 less than above prices.

*Upgrade service or kit to convert existing Superboard, C1 or UK101 systems to Mutek's enhanced specification (ask for details)* ... £40

- **Machine-code support** — an extensive machine-code monitor, co-resident with both BASIC and Assembler, and designed to simplify testing and development of machine-code routines, such as USR extensions to BASIC. Includes *load and save with auto-start*; *memory modify* allowing entry of text and graphics as well as hex instructions; *tabular hex dump/display*; *memory block move/copy/kill*; and complete *breakpoint handler* for debugging programs.
- **and more!** — disc bootstrap for OSI-type mini-floppy; revised typewriter-like keyboard decode for word-processing use; user-definable input and output, for printers and other peripherals. Designed for compatibility: your existing programs will need little or no alteration to run under CEGMON.

All this packed into a single replacement PROM! Five versions of CEGMON are available from stock: for standard (25X25 display) Superboard and C1; standard UK101; 32X48 display C1/Superboard; 32X48 display UK101; and C2 or C4. ('Specials' for other 'home-brew' display formats available to order for a small surcharge).

**Price: £29.50** includes 20 page user's handbook with program examples and reference card.

In addition to the Ohio Scientific range, we also produce our own range of boards, designed to plug straight into the 40-pin expansion socket of the C1E. Available now are:

**Memory-expansion card** with parallel port, also for standard Superboard, C1 or UK101. Fully socketed for up to 8K of reliable static memory, it also incorporates a parallel input/output port (PIA), easily accessible from BASIC for interfacing to the outside world.

**CA-80 memory/parallel card with 4K RAM** ..... £55  
**CA-80 with full 8K RAM** ..... £75

**Sound output card** based around the Texas Sound Synthesiser device, providing a full range of programmable sounds and sound effects.

**CA-82 sound output card** ..... £28

**Memory/interface board** for all OSI or UK101 type systems. Available in a number of configurations according to your needs, it carries up to 12K static RAM, 4K EPROM, two VIA parallel/serial interface devices, four 8-bit digital-analogue ports, 16-line analogue-digital input, high-speed cassette interface and programmable sound generator.

**CA-84 multi-purpose card** ..... from £95

# ITT world-wide technology available locally from Telefusion.



The famous ITT 2020 Micro Computer is now available nationwide from Telefusion. Ideal for most small and medium-sized businesses, it's one of the most versatile and cost-efficient computers you can buy. And it's on quick delivery from Telefusion and their authorised dealers - with the backing of Telefusion's expert service network staffed by fully-trained and experienced micro-computer engineers.

The ITT 2020 can be teamed up with matching Floppy Disc Drive Units and Serial Printer. In other words, it can be made into a complete data processing system.

Why not contact us or one of our dealers listed below for a complete demonstration. Alternatively, an "on-site" demonstration can be arranged through our central Micro Computer Sales Office. Call Alan Webb, Bristol (0272) 211446.

ITT 2020 Micro Computer is a complete self-contained, ready-to-use computer. Standard features include:

\*PALSOF and monitor in ROM. \*Colour graphics.  
\*Sockets for up to 48k bytes RAM. \*Cassette interface.  
\*Typewriter-style ASCII keyboard. \*High-efficiency switching power supply and rugged structural foam case.

The ITT 2020 Micro Computer video display circuiting section displays memory as text, colour graphics or high resolution graphics - software selectable. Both graphics modes can be selected to include four lines of text at the bottom of the display area. In either graphics mode the user can select (under software control) one of two memory pages to be displayed.

Come in and see just how much it can do for you.

## Telefusion

Authorised Dealers: Demacan Ltd., 2 West Priory Close, Westbury on Trym, Bristol. Tel: 621920. Aries Business Machines, 21 Manor Walk, Thornbury, Bristol. Tel: 416189. Farmplan, Netherton Farm, Ross-on-Wye, Herefordshire. Tel: 4321. Ensign, 13-19 Milford Street, Swindon. Tel: 42615. Radan Computational Ltd., 19 Belmont, Bath. Tel: 318483. Data Lease Consultants, The Manor Court House, 9 Fore Street, Chard, Somerset. Tel: 5539. Guestel Ltd., Refuge House, 2-4 Henry Street, Bath. Tel: 65379. Brindwell, 13 Brockridge Lane, Frampton Cotterell, Bristol. Tel: Winterbourne 774564. Data Link Micro Computer Systems, 10 Waring House, Redcliff Hill, Bristol. Tel: 213427. Dolphin Computer Sales Ltd., 17 Market Place, Tetbury, Glos. Tel: 53195. Data Wright Computer Services, 10 The Drive, Gosforth, Newcastle upon Tyne. Tel: 20946. Micro Business Centre, Castlebridge House, Lichfield Road, Wednesfield. Tel: 725687. Or contact the Commercial Sales Manager at Telefusion: Dudley Street, Sedgley, West Midlands. Tel: 75961. Atlas Chambers, King Street, Leeds. Tel: 450453. 63 London Road, Norwich. Tel: 28441. 45 Church Road, Hove, Sussex. Tel: 723114. 61 Queens Square, Bristol. Tel: 211446. 35 Houghton Street, Southport. Tel: 31030. 15-17 City Road, London EC1. Tel: 01-628 9587.

• Circle No. 296

# MICRO BUSINESS CENTRE

## YOUR WEST MIDLAND

APPLE II : ITT 2020 DEALERS

SPECIALISTS

IN QUALITY BUSINESS SOFTWARE

Integrated Stock / Invoice/		Apple II 16K	£695
Sales/Purchase	£1000	ITT 2020 16K	£750
Payroll	£295	16K Upgrades	£79
Sales Ledger	£295	Disk Drive	£299
Purchase Ledger	£295	With Contr.	£349
Nominal Ledger	£295	<i>Printers</i>	
Stock Control	£100	OKI Microline	£495
Incomplete Records	£450	Centronics 799	£825
Visicalc	£95	Paper Tiger	£585
Word Processing	from £150	Anadex DP 8000	£675
The Cashier —		TCM200	£395
Complete Package	£195		
For Sole Trader			
Financial Planning	£295		

\* special 0 4 GAMES DISK inc. SPACE INVADERS £10

ALL PRICES EX. VAT UNLESS STATED  
SEND REMITTANCE WITH ORDER

**CASTLEBRIDGE HOUSE**  
LICHFIELD ROAD, WEDNESFIELD  
WOLVERHAMPTON. TEL: (0902) 732687

DEMONSTRATIONS FREELY GIVEN BY APPOINTMENT  
BARCLAYCARD: ACCESS: TERMS ARRANGED

• Circle No. 297

# Enter the Computer Age video genie system

12K MICROSOFT BASIC  
16K RAM, TV MODULATOR  
INTERNAL CASSETTE



80 Columns  
70 Lines per minute  
Graphics Characters  
Interfaces to most  
machines Tractor or  
friction feed



100's of programs available  
TRS-80 level II software  
compatible

Eiron Computers Ltd

Eiron House Co Dublin  
Park Road Ireland  
Dun Laoghaire Tel: 808575/805045

• Circle No. 298

# We don't play games at Chess

*We have developed practical  
business systems*

## Software ..

### SALES

Invoicing, Ledger,  
Age of Debt, Statements,  
Sales Analysis,  
Posting of Journals,  
VAT Analysis

### PURCHASES

Purchase Invoice,  
Processing,  
Ledger, Analysis,  
Remittance Advices,  
Personnel Expense,  
VAT Analysis

### NOMINAL

Trial Balance,  
Profit and Loss,  
Balance Sheet

### PAYROLL

Payslips, Departmental  
Analysis, P60's

Dealer  
Enquiries  
Welcome

Packages  
now Available  
for TRS-80  
Model II

Fully  
Integrated  
System at  
£1250

## Benefits of Chess Software

Reduce Administrative Work,  
Provide Meaningful  
Management Information,  
Extremely Easy to Use,  
Fully Supported, with  
Documentation etc., Updates  
Available.

## The Company

Professional Staff,  
Reference Customers,  
Years of Experience.

## Other Services

Feasibility Studies (Fixed  
Price £180), Tailoring of  
Packages, Fully Tailored  
Systems, User Training.

For More Information Ring Now -  
24 Hour Answering Service

# Chess

**Chess Consultancies Ltd.**  
Progress House, 31-33 Mount St,  
Salford M3 6LQ. Tel. 061-832 6792

• Circle No. 299

# YOU DON'T NEED A MAGIC WAND TO SAVE £7,000 ON A MINICOMPUTER AND GAIN DATABASE FLEXIBILITY.



## JUST A MIRACLE.

When 2-8 Apple micros share up to 40Mb of Corvus hard disc capacity through a Constellation host multiplexer, you get a Miracle – no less. A Miracle is the answer to the bottlenecks that can happen with a mini-network. And more. A Miracle can outperform a mini-network and save you money all along the line.

Stack up a 4-Apple/Miracle system against a mini system with 4 passive terminals and you've hit on an intelligent way of saving yourself £7,000.

So much for the sizzle. But what about the hard facts?

At the heart of the Miracle is the Constellation host multiplexer. This allows 2-8 host micros to share high-speed access to one common Corvus disc drive. The micros are connected in star configuration and each of their interfaces uses the standard Corvus bus. And with the Constellation at the centre of things all the micros in the network are active.

There's also room for expansion to a multi-level network: as many as eight host multiplexers can be linked together which, in turn, allows up to 64 micros to share the disc. A user can implement

Miracle using 2-8 micros and later upgrade with no penalty in cost or software effort.

The big thing about the Corvus hard disc drive is that it can normally be accessed twenty times faster than floppies. In real terms this means 2-3 minutes for sorting a complex file instead of 15-20 minutes.

Corvus is a fixed disc 10Mb storage device which has a closed-loop filtered-air system to provide enhanced reliability in a contamination-free environment. The disc controller, based on the Z-80 processor with 16k of RAM, provides the intelligence for the system without the costs and overheads of a dedicated central computer; and the ROM-resident software is interfaced to both BASIC and the new Apple PASCAL operating systems. You can use as many as four Corvus disc drives in a Miracle system to give a total capacity of 40Mb.

And when it comes to back-up transfer, you've no problems with a Miracle: the unique Mirror system, which is included as standard, dumps up to 300Mb to video tape at 1Mb per minute.

All this is just the beginning of the Miracle – because its multiplexer opens up no end of

possibilities for sharing peripherals and communicating with other Apples in the system. 3-4 devices can be connected to each Apple in the system: for example a printer, an interface for graph plotter and digitiser, a light pen, a graphics terminal or a pair of floppy discs.

So much for the Apple-oriented Miracle. But what if you're not an Apple user? The good news is that a Miracle system can be built with other micros: S100 computers, TRS80, and Commodore in any mixture you like.

In short, a Miracle can happen in all shapes and sizes. Send for our brochure and we'll show you how.

### Keen Computers

5b the Poultry, Nottingham NG1 2HW  
tel: 0602 583254. telex: 37297 (keenco)

28 Lower Addiscombe Road,  
Croydon CR0 6AA. tel: 01-680 4646.

Keen Computers' extensive range of products and services gives you hard and soft options: we supply Apple, North Star, Commodore and Sharp computers. For details of one of the most extensive ranges of special applications software, peripherals and a host of exciting add-on goodies that will really let you take the lid off computing, send for the new KEENSTAR catalogue.

**COME AND SEE MIRACLE  
BEING PUT THROUGH ITS  
PACES ON STAND No. 3115  
AT COMPEC, OLYMPIA,  
November 4/5/6.**

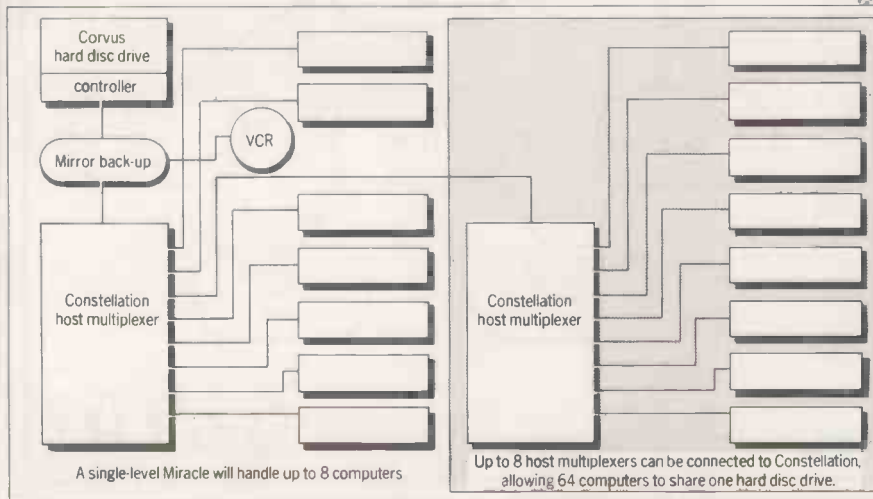



SALES AND SERVICE

**NEW**

# LIGHT PEN for Apple

## £34.00

plugs into game I/O socket + VAT +50p. p&p

Apples always in stock  
with full range of business software.  
Official tenders welcome.

## U-MICROCOMPUTERS

U-Microcomputers Limited,  
Winstanley Industrial Estate,  
Long Lane,  
WARRINGTON,  
Cheshire WA2 8PR.  
Tel: 0925-54117/8  
Telex: 627342



• Circle No. 301

JPS for electronics TTL standrd & LS CMOS  
JPS linear microprocessor ICs semiconductor  
resistor capacitors Vero & Eagle products etc

THANDAR Instruments  
by Sinclair Electronics  
SC110 Scope 10 Mhz  
10Mv/div £159.85  
DM235 3 1/2 digit £60.38  
DM350 3 1/2 digit £83.38  
DM450 4 1/2 digit £113.85  
PDM35 3 1/2 digit £39.68  
full range of  
accessories large  
s.a.e. for more details

NASCOM-1  
(a) with Nas-Sysl & 4K  
less PIO £143.74  
NASCOM-2  
(a) less PIO & Basic ROM  
£205.56 Built £263.06  
(b) standard form  
1KVRAM 1KW RAM  
£258.75  
(c) as (b) + 8K static Ram  
£350.75 Built £408.25  
16, 32 or 48K RAM  
option available 3 amp  
power supply £33.93  
full range of expansion  
accessories large  
s.a.e. for more details



Orders now being  
taken for  
J.P.S. VFC £120 + VAT  
Memory at £1.20 per 16K  
J.P.S. Cos.  
Operating System  
Auto Index and  
File Handling  
£45 + VAT

A selection from our  
range of Components

Panel meters fsd 10ma  
2 1/4 x 2 1/4 inches £2.50  
3819 FET 23p  
Led watch modules  
4 for £2.00  
Ten turn pots 50K  
£2.00 Counterdial  
for same £1.50

Lists 20p + large s.a.e. VAT inclusive prices.  
Add 75p PP on orders under £10 send to  
JPS Dept PC 11 East St., Colne, Huntingdon, Cambs.

• Circle No. 302

# SOFTWARE by the PROFESSIONALS



ARE YOU FED UP WITH WADING THROUGH THE SOFTWARE JUNGLE???  
CAN'T YOU FIND ANY REAL BUSINESS SOFTWARE???

## STOP LOOKING!!! WE'VE GOT IT

If you're looking for a £50 business package or games DON'T call us.

We are one of the foremost micro-computer applications 'Software Houses' in the country and our packages developed for the UK, offer facilities normally found only on larger and more sophisticated computer systems.

The packages are simple to use, robust, secure against crashing, extremely flexible and cover most of the normal requirements of a small business.

We provide a 12 month warranty, with all our software products. plus advice, support and backup.

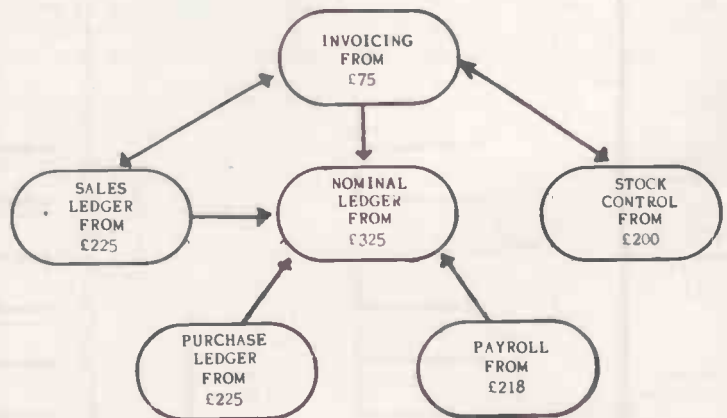

TRIDATA MICROS LTD.,

SMITHFIELD HOUSE, DIGBETH, BIRMINGHAM B5 6BS TEL. 021 622 6085



• Circle No. 303





# Vision Business Systems

## FOR YOUR

# SUPERBRAIN™



### System Specification

- Dual 4MHz Z-80 C.P.U.s
- Dual double-density mini-floppies (320K bytes)
- Dynamically focused 12 inch CRT
- 25 lines by 80 characters  
8 × 8 in 8 × 12 field
- Full ASCII keyboard
- S-100 Bus via direct connection
- Dual synchronous/asynchronous RS 232 ports
- CP/M™ operating system
- Single desk top unit
- Day 1 Maintenance £155.00 p.a.

**£1495**  
COMPLETE  
(EX. VAT)

For further information please contact: —  
**VISION BUSINESS SYSTEMS LTD.,**  
58 ST. PETER'S STREET,  
ST. ALBANS, HERTS.  
TEL. ST. ALBANS (0727) 33744

### Software Support

- Wide Range of Standard Software — COBOL, BASIC, PASCAL, FORTRAN, APL
- Sophisticated Application Packages — PAYROLL, SALES ORDER PROCESSING, SALES LEDGER, INCOMPLETE RECORDS, nominal ledger.
- WORD STAR — Word Processing Package
- Customised Software Designed To Meet Your Business Needs by Our Specialist Consultants

# SAVE ON APPLES PETS DISCS NASCOM

FREE DELIVERY add 15% VAT to all prices

- 48K APPLE II PLUS £700
- 8K PET with integral cassette £400
- NASCOM II KIT with 16K RAM £305
- 10 DISCS, boxed (Verbatim, Kybe) £25
- TEAC FD-50A single/double density Floppy Drives £155

Allow 14 days delivery, SECURICOR delivery at extra cost  
MAIL ORDER MICROS, PO BOX 301, BURSLEM  
STOKE-ON-TRENT, ST6 4HY, PHONE 0782 825391

Barclaycard & Access accepted  
Prices subject to change  
without notice  
Special offers subject to  
availability of stock  
E & OE

• Circle No. 305



## MINIATURE KEYBOARDS

SPECIAL OFFER

RAPID TURNAROUND  
CUSTOM DESIGN IS  
OUR SPECIALITY



Apex is manufacturing miniature keyboards in volume for the T.V. and Computer Industries. Substantial cost savings have been made and these are now being offered to the end user in this Introductory Special Offer. Ideal for Interfacing to micro based systems via an 8 bit ASCII data bus or a serial 20mA/RS232 port these attractively styled keyboards have all the features of full sized units at a fraction of the cost.

- Miniature ASCII keyboard MKBOI £40.00
- Cased ASCII Keyboard MKBOIC £45.00
- Serial Cased Keyboard (20mA) MKBOICMA £65.00
- Serial Cased Keyboard (RS232) MKBOICRS £65.00
- BCD Encoded Hex Pad MHPOI £17.95
- Ribbon Cable and Connector RCC20 £2.50

When ordering serial interfaces please specify Baud Rate.

APEX MICROSYSTEMS LTD 06333 69169  
Unit 22 Springrate Industrial Estate  
Cwmbran, Gwent

• Circle No. 306



## Some new introductions by the Midlands Computer Centre...

We celebrate our first birthday with news of new introductions available from the Micro Computer Centre.

NEW

HORIZON

NEW

CROMEMCO

NEW

NEWBRAIN

(As soon as available)

In addition to Nascom and Commodore micro computers

### PERIPHERALS

(Excluding printers)  
Sharp Cassette Decks. Crofton 10"  
Cased Monitors.

### PRINTERS

Nexos Ricoh RP 1600 Daisy Wheel Printer. Diablo Daisy Wheel Printer. Nascom Micro Imp. Dot Matrix Plain Paper Printer. Centronics Dot Matrix. Anadex Dot Matrix. Newbury Laboratories Dot Matrix Impact Printer.

### ADD-ONS FOR NASCOM

Input/Output Board. PIO Kit. Counter Timer Kit. UART Kit. (Colour Board Programmable Character Generator Board. Floppy Disc System (Single Drive) available in September). Nas-Pen Text editor. ZEAP 2.0 in EPROM or on Tape. Nas-Sys 3 Enhanced version of Nas-Sys 1. Nas-Dis - Disassembler. Debug - Dynamic Debugger.

### BITs & PCs

Tool Kit. Port Probe. Hex Key Pad.

### WILLIAM STUART

Colour Graphics for Nascom 1 & 2.

### MERSEYSIDE NASCOM USER GROUP

ROM/EPROM Board for Nasbus.

### EXTRAS

Henry's EPROM Burner. Antex Soldering Irons & Bits.

### SOFTWARE

Northstar. CAP-CPP. Cromemco. Petsoft. Supersoft. Nascom Games.

### BOOKS

Very full range of books on 6502, Z80, Languages, Interfacing, Introductory books and games and General Programs.

### MAGAZINES

Personal Computer World. Computing Today. Practical Computing. Educational Computing. Liverpool Software Gazette. Printout.

### ASK ABOUT THE KENILWORTH CASE

The "Kenilworth" Case. Microtype Case. Veroframe.

### BUSINESS & LEISURE MICROCOMPUTERS

Castle Interface.

## Business & Leisure Micro Computers

16 The Square, Kenilworth, Warwickshire CV8 1EB. Tel: (0926) 512127

• Circle No. 307

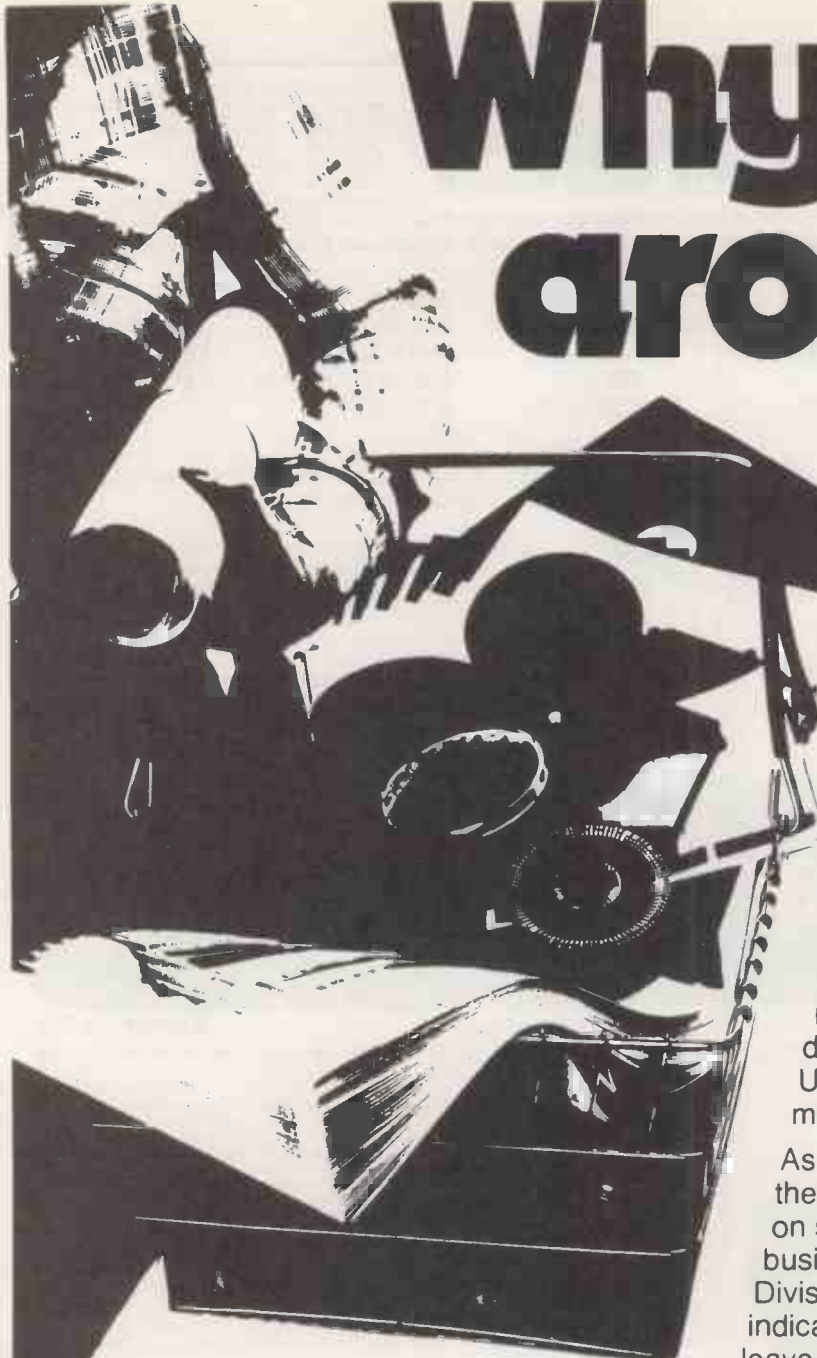

# Why shop around...

## ...for all your computer supplies?

Shopping around for the best price and best delivery dates is alright for those who have time to do it – saving a few pence here and a few days there!

Why bother – we've done all that? We'll give you the best delivery because it's all waiting in our warehouse – and the best price too!

How? Well as appointed magnetic media distributors for 3M and sole distributors for Wang consumables in the UK we buy bulk bigger than most, which means we get a price better than most.

As specialists in providing consumables to the computer industry, we concentrate on supplies and allow you to get on with the business of computing. Give our Supplies Division a call now, or tick the list below to indicate what items you'd like prices on and leave the rest to us.



**M.I.B.F.**

Barclays Bank Chambers  
Pegg Lane  
Kirkgate, Tadcaster  
Tel. (0937) 832868

Name \_\_\_\_\_

Address \_\_\_\_\_

Company \_\_\_\_\_ Position \_\_\_\_\_

Please send me information on the following items:-

<input type="checkbox"/> Data listing paper	<input type="checkbox"/> Disks	<input type="checkbox"/> Magnetic tape storage
<input type="checkbox"/> Mini diskettes	<input type="checkbox"/> Storage modules	<input type="checkbox"/> Computer room furniture
<input type="checkbox"/> Diskettes	<input type="checkbox"/> Printer ribbons	<input type="checkbox"/> Office desks
<input type="checkbox"/> Cassettes	<input type="checkbox"/> Data processing files	<input type="checkbox"/> Chairs
<input type="checkbox"/> Cartridges (data)	<input type="checkbox"/> Storage cupboards	<input type="checkbox"/> Filing systems
<input type="checkbox"/> Cartridges (disc)	<input type="checkbox"/> Diskette storage	<input type="checkbox"/> Printers
<input type="checkbox"/> Magnetic tape	<input type="checkbox"/> Disk storage	<input type="checkbox"/> Visual display units

Cut out and send to MIBF, Barclays Bank Chambers, Pegg Lane, Kirkgate, Tadcaster.

PC11

# Suppliers to Britain's Computer Industry

• Circle No. 308



# centralex

**CENTRALEX-LONDON LTD**  
8-12 Lee High Rd, London SE13  
Tel: 01-318 4213/4/5/6/7  
9.30 am - 5 pm Mon to Fri -  
Evenings and weekends by  
appointment

A comprehensive range of Microcomputers Equipment, Peripherals, Software and Services for those who value Professional Standards, Guidance and Continuing Support for Hardware and Software.

APPLE  
TEXAS  
MICROPOLIS  
DIABLO  
MICROLINE

PET  
OHIO SCIENTIFIC  
CENTRONICS  
QUME  
HITACHI

ITT 2020  
CROMEMCO  
ANADEX  
DEC  
LEXICON

EXIDY  
MICROSTAR  
INTEGRAL  
DATA GENERAL  
ETC. ETC.

HORIZON  
SHUGART  
TELETYPE  
EPSON

## INFORMEX-80 Printer

£399+VAT



Special offer - for a limited period

For PET, APPLE, EXIDY, TRS80, ETC  
A high quality, high speed printer  
(125 cps) Upper and lower case letters  
plus graphics as standard  
Interface and cable for TRS80, PET,  
APPLE or RS 232 £69 + VAT  
Tractor feed option only £39

ALSO Training, Consultancy, Systems Design,  
Programming and Software

PAYROLL - INVOICING - STOCK CONTROL -  
SALES/PURCHASE LEDGER - VAT - MEDICAL  
RECORDS - EDUCATIONAL & ENGINEERING  
PROGRAMMES - HOTEL RESERVATION - ESTATE  
AGENTS - BUILDING MAINTENANCE - COBOL -  
FORTRAN - ETC.

Maintenance Contracts including stand-by equipment during repair  
periods - Free Delivery Nationwide - Terms arranged - Credit Cards and  
official orders accepted.



• Circle No. 309

## Explorer/85

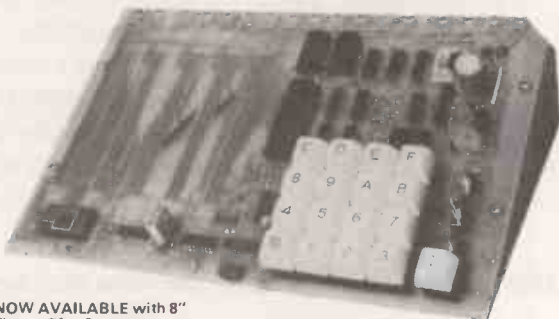

NOW AVAILABLE with 8"  
Floppy Disc System  
An inexpensive 8085S Based S-100  
Computer system designed for maximum flexibility

EXPLORER/85 offers you real flexibility, you can build the exact system you  
require. EXPLORER/85 can be your Beginners system, OEM Controller or IBM  
formatted 8" disc Business system. You don't buy more than you need.  
Prices start from £91.75

**HARDWARE:** Mother board (A)8085cpu, 8355 ROM with powerful 2K monitor  
system and I/O ports, 8155 RAM-10 with 256 bytes of scratch pad. Two S100  
pads, room for RAM, ROM, PROM, EPROM and S100 expansion plus prototyping  
space. Level 8 allows address decoding for onboard RAM & EPROM, address &  
data bus drivers for onboard expansion. Wait state generator.

**SOFTWARE:** Microsoft-90 in ROM or cassette. or CP/M disc operating system  
which will support four 8" drives.

**PACKAGE EXPLORER/85** is available in kit form or assembled complete or in  
separate levels to suit your requirements and pocket. Cabinets and other peripherals  
are available.

**VIDEO KEYBOARD TERMINAL:** Microprocessor controlled, 1K RAM character  
generator, processor controlled cursor control and parallel ASC11/Baudot to serial  
conversion plus serial to video processing all crystal controlled. Upper & lower  
case keyboard, choice of 32 or 64 characters by 16 lines with select baud rate,  
RS232 or 20ma loop.

In kit form £114 or assembled £139.00

**64K 'JAWS' DYNAMIC RAM S100 BD Intel 8202 Controller, hidden refresh,**  
low power consumption, latched data outputs, 4116 RAMS, Onboard crystal,  
8k bank select, fully socketed designed for 8080, 8085 and Z80.

16K kit £149: W&T £169: 32K kit £218: W&T £328: 48K kit £287: WIT £307:  
64K kit £346: W&T £376: 16K expansion kits £69.

8" DISC DRIVE SPECIFICATIONS\* Control Data Corp professional drive \*LSI  
controller\* Write protect\*Single & double density\*Data capacity: 401, 016 bytes  
(SO) 802, 032 bytes (DD) unformatted\* Access time 25ns (one track) ..... £392  
DISC CONTROLLER BOARD SPECIFICATIONS\* Controls up to 4 8" drives\*  
1771ALS1 (SD) floppy disc controller\* On board data separator (IBM COM-  
PATIBLE)\* 2 serial I/O ports\* Autoboot to disc system when system reset\* 2716  
PROM socket for user custom applications\* Onboard crystal controlled\* Onboard  
I/O baud rate generators to 9600 baud\* Double-sided PC board (glass epoxy) £156  
DISC DRIVE CABINET/POWER SUPPLY UNIT\* De Luxe steel cabinet for two 8"  
drives with individual power supply for maximum reliability and stability ..... £79  
SAVE 10% on complete floppy system 1 drive 8" Controller Board\* Cabinet\*  
Set of cables ..... £582  
SOFTWARE\* CP/M 1.1.4 ..... £75  
\*Microsoft extended Basic ..... £195  
\*CP/M 2.0 ..... £99  
Complete Business Software Package\* includes CP/M 2.0\* Microsoft Basic\*  
General Ledger\* Accounts Receivable\* Accounts Payable\* Payroll Package  
.....£495

ELF11 RCA COSMAC 1802 cpu computer Kit. Ideal for  
Hobbies\* EDUCATION\* OEM Control applications\*  
Expands to full 64K computer. Basic Board with  
Graphic chip £59.95\* Extensive range of Add-Ons\*  
Send for fully illustrated brochure.

## NETRONICS TVM MONITOR

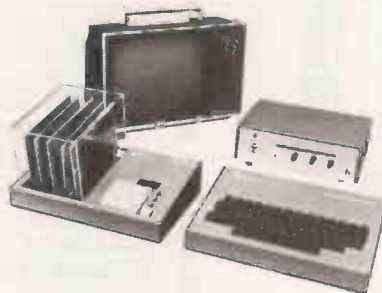

- Designed for computers, closed  
Tape Recorders circuit TV and  
Video
- 9" B/W Screen
- 10MHz band width
- Input Impedance High and Low
- Compact, light weight (13 lbs)
- Solid state circuitry
- Stabilized power circuit.
- Metal Cabinet (two tone Cream)
- Input level range: - 1 to 2v (p.p)
- 240v 50hz
- Size 9" x 9" x 9 1/2"
- Price £99.50

ALL PRICES ARE EX VAT & P&P

Newtronics  
255 Archway Rd  
London N6 5BX  
Tel 01-348 3325 anytime  
Open 9.30am - 6pm Mon.-Sat.

• Circle No. 310

# Get the latest on PET...



**Dial 01-579 5845.**

Adda make it their business to get in first on all that's best and new in PET hardware and software... and in finding out how to make the latest advances work more profitably for you.

All the advice, assistance and arrangement of demonstrations you could ask for are there for the taking. And that's just for starters. Long term Adda look after your future requirements with software, full engineering support and maintenance contracts that can include machine loan.

In addition to the 16k PET 3016 and 32k PET 3032, Adda offer you the new 32k PET 8032—with 80 columns, 12-inch screen and a keyboard that really gets down to business. Recent advances make possible some exciting applications for these mighty micros.

Link the 32k PET up to the Wordcraft word processing program and you have a very sophisticated word processing system for less than £4000. It's a word processor and more—because it can also be used as a small business machine.

The Wordcraft program comes on a mini floppy disc ready for use on a Commodore 3040 diskette drive. The whole system gives you word processing to standards achieved by expensive

purpose-built machines; and you can use a large selection of output printers including dot matrix, golfball and daisy wheel. So much for words—now for some action: phone 01-579 5845.

If you're looking for mainframe access, the Communicator 1 mainframe-PET link enables file transfer to be made in both directions... with a PET Communicator system configured with either dual floppy disc or cassette tape drive and a printer.

Files transferred from mainframe to PET can be manipulated locally and data transfer monitored on the PET screen. It's a fast way of cutting costs on bureau time share—and it also doubles up as a fast normal terminal. The Communicator 1 mainframe-PET link paves the way to big cost savings. Your first step is digital input to 01-579 5845.

More cost savings can be realised when you link up three to eight PETs to one Commodore disc drive and a printer using Mupet (Multi-User PET)—and you don't have to make any program changes. As a Mupet dealer, Adda can put you fully in the picture. Just phone 01-579 5845 for a demonstration of Mupet being put through its paces.



## adda

Adda Computers  
14 Broadway  
West Ealing  
London W13 0SR  
Entrance in  
Kirchen Road

**we add up to a great deal.**

• Circle No. 311

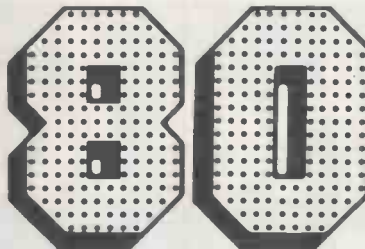

26th Nov — WEDNESDAY — 10am-6pm  
 27th Nov — THURSDAY — 10am-8pm  
 28th Nov — FRIDAY — 10am-6pm  
 29th Nov — SATURDAY — 10am-6pm  
 30th Nov — SUNDAY — 10am-4pm

COMPONENTS DEMONSTRATIONS SPECIAL OFFERS MAGAZINES BOOKS

Royal Horticultural Halls Elverton Street

Westminster London SW1

November 26-30 1980

It's all at Breadboard '80

This is **the** exhibition for the electronics enthusiast. From November 26 -30 there is only one place in the universe for the electronics enthusiast to be — Breadboard '80, at the Royal Horticultural Hall in London. The majority of leading companies will be exhibiting, including all the top monthly magazines in the field. There will be demonstrations on most stands and many feature special offers that are **EXCLUSIVE** to Breadboard!

All aspects of this fascinating field are catered for, from CB to home computing, so whether you want to buy a soldering iron or a synthesiser — or just keep up to date with your hobby — don't miss Breadboard '80.

AVOID QUEUES — GET ADVANCE TICKETS

Send to: Advance Tickets, Modmags Ltd,  
 145 Charing Cross Rd, London WC2H 0EE

Please send: ..... tickets @ £1.50

..... tickets @ £1.00 (Student/Child/OAP)

TO: .....

I enclose P.O./Cheque for £ .....

• Circle No. 312

**the  
 software  
 house**

146 Oxford St.  
 London W1.

**Our NEW Catalogue**

**is now available !**

**100'S of superb programs !**

**PLEASE RUSH ME A COPY.....**

**I enclose £1 (deductible from 1st  
 order) for your descriptive and  
 illustrated catalogue**

**Name**

**Address**

• Circle No. 313

**MONITORS**  
 B&W — GREEN — COLOUR

9" GREEN (IDEAL APPLE/ITT)	£155
9" B&W	£136
12" B&W	£175
14" B&W	£189
17" B&W	£225

TOP QUALITY, HIGH RESOLUTION MONITORS GUARANTEED 12 MONTHS, CARRIAGE/V.A.T. EXTRA. FULL RANGE OF B&W AND COLOUR RECEIVER MONITORS AVAILABLE, P.O.A.



DEALER ENQUIRIES WELCOME

**HAMM & GIBSON**  
 MONITOR & VIDEO SPECIALISTS  
 43 MALDEN WAY, NEW MALDEN  
 SURREY KT3 6EA  
 01-942 9635

• Circle No. 314

# SUPERBRAIN™

U  
P  
E  
FROM

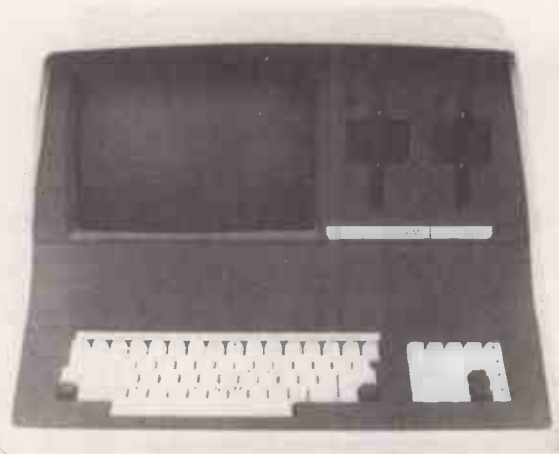

**£1495**  
COMPLETE  
+ VAT

## Bonnes Nouvelles Business Systems Ltd

R  
A  
I

- Dual 4MHz Z80 C.P.U.s.
- Dual double density mini-floppies, (320 Kbytes).
- Dynamically focussed 12" CRT.
- 25 lines by 80 character 8 x 8in 8 x 12 field.
- S100 bus via direct connection.
- Dual synchronous/asynchronous RS232 ports.
- CP/M Operating System.
- Single Desk-top unit.
- Wide range of standard software (FORTRAN, COBOL, BASIC, APL, PASCAL). Sales order processing, Invoicing, Sales Ledger, Purchase Ledger, Nominal Ledger, Payroll, Word Star (Word Processing).
- Day 1 maintenance £155.
- Full Client Support.

**PHONE Basildon (0268) 411249**

Bonnes Nouvelles Business Systems offer a complete service which covers advice, systems design, training and customising of standard software to individual requirements. Specialist services include the supply of low cost Word Processing systems, integrated accounting systems and many other systems at highly competitive prices.

Bonnes Nouvelles is 'GOOD NEWS' ring us and find out.

**Bonnes Nouvelles Business Systems Limited**  
162 Somercotes, Basildon, Essex  
Tel: Basildon (0268) 411249

*SUPERBRAIN™ is the registered trademark of Intertec Data Systems.*

# Trident



£670.00



£2650.00

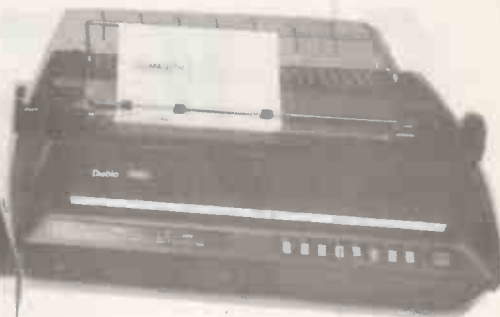

£2150.00

Configuration shown is for word processing including WORDSTAR £5450

- ★ Full Business Systems available
- ★ 64K 4MUZ Memory
- ★ Rack Mounting available
- ★ Interface to most VDUS and printers
- ★ Wide range of high level Languages available
- ★ Fastest CPM Machine
- ★ 6 slot S100 mother board
- ★ 2 or 4MBYTE Disc Storage

**SIGMATECH LTD.**  
ELECTRONICS

For further information:- Tel: (0734) 587000  
22, Portman Road, Battle Farm Estate, Reading, Berks.

• Circle No. 316



# apple<sup>®</sup> computer

Sales and Service

**16K Apple £695**  
**+ VAT and carriage**

We also supply • Lear Siegler ADM3A — **£515** for one.  
**£500** each for two or more.



• Verbatim  
Single-sided minidiskette — **£23** per box of 10.

— **£21** for two boxes or more.  
Double-sided 8m. diskettes — **£40** per box of 10

— **£38** for two boxes or more.

Carriage inclusive, VAT extra.

We are also a Cromemco dealer supplying turnkey packages for Estate Agents, Solicitors and Wholesalers.

# Total Concept Systems Ltd

373 High Road Leyton, London E10. 01-539 7194 (day) 01-554 1152 (eve)

• Circle No. 317



# Z-EIGHTIES

## TERODEC

The ideal system for business use with unrivalled flexibility

64K Ram standard  
4 MHz Z-80 CPU  
1-4 Mb. Floppy disc storage  
Fixed or cartridge disc  
Single or multi user  
Variety of interfaces  
Maintenance available  
Ample Software

Now available 5, 10, or 32 Mb Hard Discs

MP/M multiuser

DP/NET network system imminent

Prices from £3000

## EXIDY

Superb small system with advanced features

Z-80 CPU  
S-100 Bus  
C/PM MDOS Microsoft basic etc.  
Unique ROM Pacts  
Exceptional Word Processing options  
315 K Floppy disc storage  
Dual cassette interface  
RS-232 and Parallel outputs

Single disc drives to be attached directly to the computers 50

way expansion interface now available

Modularity permits a range of configurations

Prices from £749 for 16K machine

## MICROLINE-80

The ver small and quiet dot-matrix printer

Friction and pin feed standard  
Tractor feed option  
Prints at 5, 10 or 16.5 cpi  
Print speed 80 cps  
80 or 132 columns  
Serial or parallel interfaces

Price £425

## RICOH RP-1600

The latest daisywheel printer to reach the marketplace

Friction feed standard  
Tractor feed option  
Variable pitch variety of fonts  
Print speed 60 cps!!  
Very advanced technically  
Interfaces for most computers

Price £1595

## BUSINESS SOFTWARE

### Interface Software

Ledger systems from £295

### Graham Dorian

Ledger Systems from £500

### Osborne Associates

Ledger systems from £150

## SORCERER SOFTWARE

### The Sorcerer Toolkit

Loads from cassette and runs as an extension to the normal Basic to give:—

SCREEN EDITOR: just move the cursor to any line on the screen and insert, delete or amend!

LIST a,b: lists program from line a to b.

LIST a,: lists from a to end.

LIST b,: lists from start to b.

KILL a,b: delete from line a to line b

(also KILL a, and KILL b,).

RENUMBER program lines.

OLD command recovers old program after NEW CLOAD or RESET.

RANDOMISE: starts off random number series differently each time.

AUTO automatically numbers program lines for you

LINK joins basic programs together

FIND searches your program for a specified string of characters

STEP causes program execution one line at a time

Many other useful features to give your Sorcerer everything you could wish for

Runs on 16, 32 or 48K machines.

Price £30.00 plus V.A.T. plus 50p. p & p (35.00 total) and

includes one years membership of SPEC (Sorcerer Program Exchange Club) existing members may deduct £5.00

### New from America QUALITY SOFTWARE

SHAPE MAKER — You can construct fancy shapes or a new alphabet in minutes with the help of SHAPE MAKER an on screen editor for defining graphics.

Single Character Commands allow you to define a graphics character and assign it to any graphics key you choose. The character you design is displayed as you build it at eight times normal size. On screen Buffer Commands allow you to move characters in and out of the buffer area of the screen, where up to ten enlarged characters can be stored simultaneously. Cursor control commands allow you to construct multi-character shapes by turning dots on and off in the buffer area.

The 12 page instruction booklet contains full descriptions of the 26 commands and tells you how to save shapes and use them in your Basic programs.

Two example Basic programs are included, one of which automatically constructs a battle tank.

Price	£12.00
Martian Invaders	£12.00
Software Manual	£10.00
Development Pac Extension	£17.00
Smart Terminal	£30.00
Forth	£30.00
Fastgammon	£13.00
Maze	£9.00
Debug	£12.00
Plot	£12.00

Send for list of Over 200 programs

**BASIC COMPUTING**  
251 Bradford Road, Keighley,  
W. Yorks BD21 4DG  
Tel 0535-63145/63094

**MICROPUTE**  
9 Prestbury Rd.,  
Macclesfield, Cheshire  
Tel 0625-612759/612818

**PETE & PAM COMPUTERS  
(PETE & PAM FISHER)  
MAILORDER APPLEFARE BY  
REPUTABLE COMPANIES  
AT FAIR PRICES**

**MICROSOFT**

**Z-80 SOFTCARD — 175.00**

Runs software written for Z-80 based systems on APPLE. Inc. C/PM and Microsoft 5.0 Basic.

**TYPING TUTOR — 8.95**

Lear to type on your APPLE! 16K tape.

**ADVENTURE — 15.95**

For the first time, the original, uncut ADVENTURE fully implemented on a personal computer. 32K Disk

**MOUNTAIN HARDWARE**

**MUSIC SYSTEM — 265.00**

Generates the sound of any musical instrument — real or imagined! Digital synthesiser with SIXTEEN voices, Stereo output, Graphical input using light pen (provided); PADDLES; OR KEYBOARD: Includes membership of Users Club.

**M & R ENTERPRISES**

**SUP-R-TERMINAL — 195.00**

The best of 80 column video cards! 80\*20 lines, shift loc mod. 128 U & L case 5\*8 dot ASCII char.

**HIGH TECHNOLOGY**

**DATA BASE MANAGEMENT SYSTEM — 49.95**

Seen elsewhere in this mag for 100! Helps you design your own system for manipulation and format of large amounts of data. Generates reports to your design.

**INFORMATION MASTER — 73.95**

Written by the author of "DBMS" and the author of "The Cashier" (tm). Data base system that performs calculations on data as you enter it into a field. It's worth buying a computer just for this!

**DATA MASTER — 49.95**

Powerful accessory to "DBMS" and "Info Master", adds immense versatility to both! Re-define, merge sub-divide files; re-arrange, combine, add, delete files; calc. new values, change print format. NEW!

**PERSONAL SOFTWARE**

**VISICALC — 75.00 (PET version — 96.95)**

Award winning program. Save 20.00, buy from us!

**CCA DATA BASE (latest version) — 49.95**

Stores and retrieves information. 130 page manual.

**DESKTOP PLAN — 49.95**

Flexible business planning and development system, design your own business model. Extensive manual.

**GAMES! Disk — 13.95, Tape — 9.95**

Microchess 2.0 — Checker King — Gammon Gamber — Bridge Partner — Stimulating Simulation (tape).

**CALIFORNIA PACIFIC COMPUTERS**

**SUPER GAMES! — all on disk**

**HEAD-ON — 13.95**

Another arcade game from Japan — this one with two racing cars running round a track. Great fun!

**TRANQUILITY BASE — 13.95**

**TRILOGY — 15.95**

**BILL BUDGE'S SPACE ALBUM — 20.95**

PLEASE ADD 15% V.A.T.

POSTAGE AND PACKING FREE

**WE WANT TO BE YOUR MAILORDER  
SUPPLIER. IF YOU KNOW WHAT  
YOU WANT — AND DON'T WANT TO  
PAY AN INFLATED PRICE —  
GIVE US A CALL.**

**WE'LL TRY OUR BEST!  
TEL. 01-677-2052 (24 HOURS)  
SEVEN DAYS A WEEK  
98 MOYSTER ROAD  
LONDON, SW16 6SH.**

• Circle No. 319

**\* TX-80B 80 COLUMN DOT MATRIX PRINTER**

**FEATURES**

- Reliability
- Low cost
- 70 lines/minute
- Compact size
- 96 Chars + Pat Graphics
- Condensed line, enhanced print
- Self-test
- 5 x 7 dot. matrix, 6 x 7 for graphics
- Centronics parallel interface standard

**EPSON**

**£349**

**+ VAT**



**OPTIONS:**

- \* PET, APPLE, TRS80, VIDEO GENIE, RS232, Interface board and cable £40 each + VAT
- \* NASCOM Interface cable £12.

**\* MEMORY BARGAINS**



ALL components are manufactured by leading companies and guaranteed full specification.

	1+	10+	100+
4116-200ns, 16K x 1			
DRAM Ceramic	3.75	3.35	2.80
2708-450ns, 1K x 8			
EPROM	4.75	4.00	3.45
2716-450ns, 2K x 8			
INTEL Type single +5V	10.45	9.65	8.45
2732-450ns, 4K x 8			
INTEL Type single +5V	28.85	23.45	18.99
2114-1K x 4			
SRAM	3.95	3.60	3.00
			+ VAT

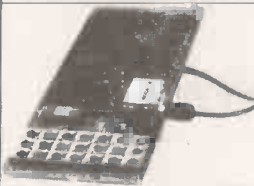

The versatile microprocessor development tool, connects directly to TV or monitor, can copy burn, verify 2708, 2716 EPROMS has serial (RS232) or parallel link for any small computer — only £120 built and tested, kit £100, power supply £20 equivalent development systems cost £500+ + VAT



**NOW £319 + VAT**

**VIDEO GENIE SYSTEMS EG3003 —**

Based on TRS-80, utilises Z80, 12K Level 11. Basic 16K RAM, INTEGRAL CASSETTE Deck, UHF O/P, All TRS-80 features.

**Interfaces to EPSON printer.**

**12" MONITOR**  
Ideal for Personal and Business Computers £65 + VAT

**VIDEO GENIE EXPANSION BOX**  
**£219 + VAT**

- Low Cost EPROM Eraser £34 + VAT
- High Speed Eraser typically 4-7 mins 2708 £97 + VAT

**Q-Tek Systems Ltd**

2 Daltry Close, Old Town, Stevenage, Herts  
Tel (0438) 65385

**24 HOUR DESPATCH**  
(Stock Permitted)

• Circle No. 320

**Electronics for the 80s**

**Microprocessor Short Courses**

The department of Electronic and Communications Engineering is offering a series of short courses aimed at professional engineers for 1980/81.

**6502 Machine code programming:**

2 days. £75  
17-18 Nov 12-13 Jan  
16-17 Feb 16-17 Mar

**Applications Engineering:**

3 days £250  
3-5 Dec 4-6 Mar

**Microprocessor Troubleshooting:**

3 days £300  
5-7 Nov 4-6 Feb

**8085 Applications and Software:**

Pt 1: Introduction to 8085 5 days £200  
20-24 Oct 24-28 Nov  
19-23 Jan 23-27 Feb  
Pt 2: Applications 5 days £200  
10-14 Nov 8-12 Dec  
5-9 Jan 9-13 Feb 9-13 Mar

Details from Secretary,  
Department of Electronic and  
Communications Engineering,  
Polytechnic of North London,  
Holloway, London N7 8DB

**The Polytechnic  
of North London**

• Circle No. 321



# Portable Microsystems Limited THE LOGICAL APPROACH TO DIGITAL LEARNING

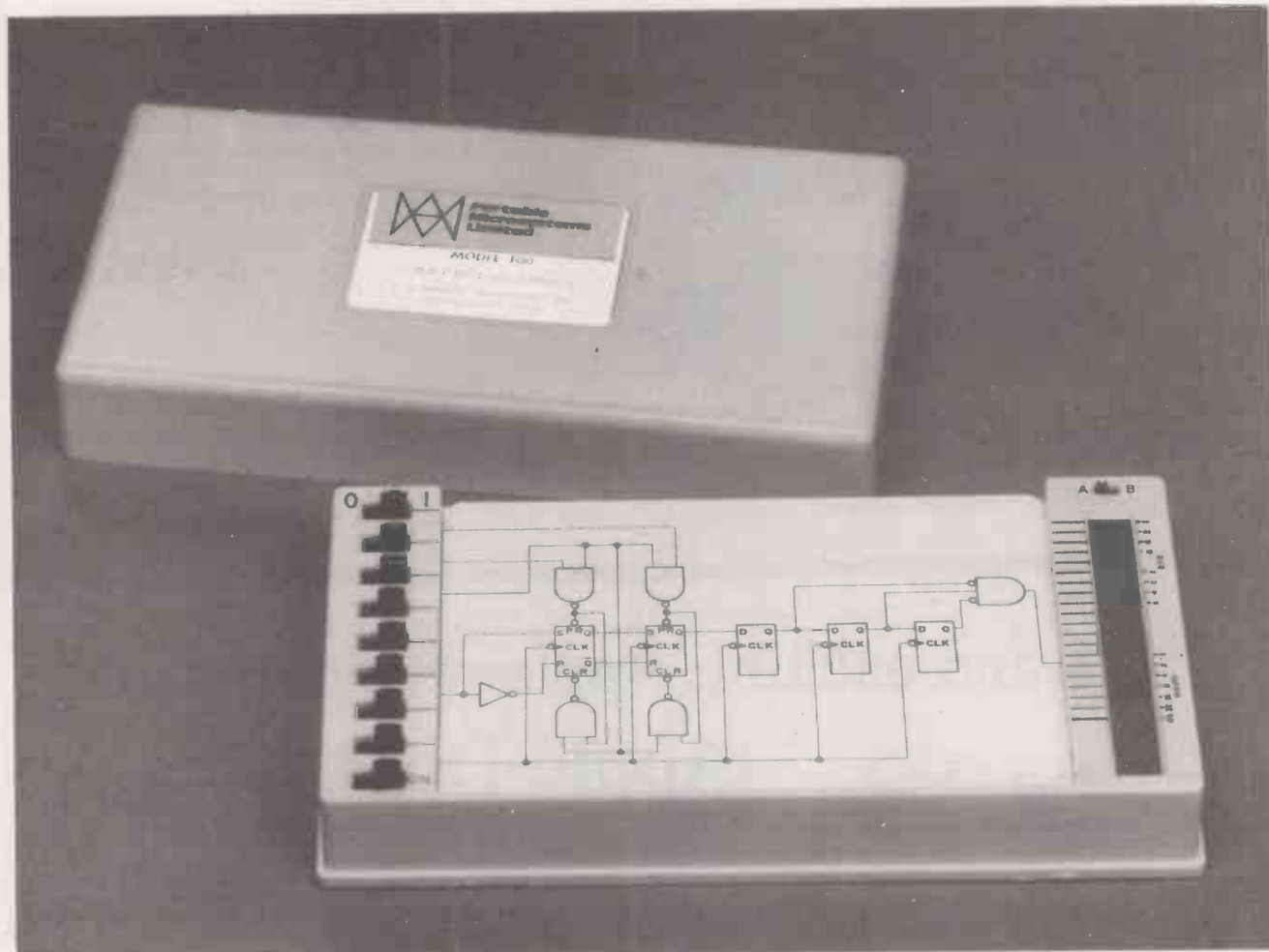

THE ELT 100 FROM PORTABLE MICROSYSTEMS IS A REALLY SIMPLE LEARNING AID FOR THE HOBBYIST, STUDENT OR PROFESSIONAL. KEEP UP IN THE SILICON CHIP REVOLUTION WITH THE HELP OF THE ELT 100.

**PRICE: £59.95 + V.A.T. + £2.50 p+p**

**DELIVERY: EX-STOCK**

**MAIL ORDER PRICE £71.82 inclusive**

*Note: Prices are subject to change without notice.*

Forby House, 18 Market Place, Brackley, Northants NN13 5SF

Telephone Brackley (0280) 702017

Telex Micro 83147

• Circle No. 322

# APPLE II



## The Prestel connection for the Apple II

- access Prestel
- store and process information pages
- create your own pages

For the Prestel user and  
Information Provider **£595 + VAT**

Also Apple software from Owl Computers:

LISP language **£58 + VAT**  
Microayd assembler **£50 + VAT**



**Owl Computers**

18 Hadham Road,  
Bishop's Stortford, Herts. CM23 2QR  
Telephone: (0279) 52682

• Circle No. 323

## New and exciting Applesoft programs

### **NEW!** the correspondent

By Roger Wagner

by R. Wagner

**THE CORRESPONDENT** is sure to be one of the most versatile programs in your library! It can be used as:

**A Text Processor:** Upper/lower case, 1-80 cols. (4-way scrolling). Text move/copy/insert/delete, tabbing, justify text, auto-centering and more!

**A Database** (with or without printer!) Extremely fast find routine and easy editing make it a natural for free-form data files. Create and fill out forms, access phone lists or index your magazines.

**A Programming Utility:** (printer or not). Examine, edit, transfer random or sequential text files. Create versatile exec. files. Even put bi-directional scrolling in your own programs!

Apple disk £29.95 + VAT

### Roger's Easel

by R. Wagner

At last a program which allows you to draw colour pictures in lo-res graphics, and then permanently link them to your own Integer or Applesoft programs. Linked pictures can be displayed on either text/graphics page. (Integer basic).

Apple disk £14.95 + VAT

### Apple-Doc By Roger Wagner

An Aid to the Development and Documentation of Applesoft Programs

This 3 program set is a must to anyone writing or using programs in Applesoft! It not only provides valuable info. on each of your programs, but allows you to change any element throughout the listing almost as easily as you would change a single line!

With Apple-Doc you can produce a list of every variable in your program and the lines each is used on, each line called by a GOTO, GOSUB, etc., in fact, every occurrence of almost anything! You can rename variables, change constants and referenced line numbers or do local or global replacement editing on your listing.

Apple-Doc is a must for the serious Applesoft programmer.

Diskette complete with full documentation £24.95 + VAT

### tridee ©Robin L. Frost

An exciting new addition to your Pascal library — enables you to create 3D graphics, viewable from any angle and distance. As easy to use as Turtlegraphics.

Procedures include Ortho, Perspec, Rotate, View, Move to-3, View-from.  
Complete with comprehensive instructions £49.95 + VAT

**Apple World** is here. The fast 3D graphics package that runs on your Apple II plus. Zoom, pan, tilt and scale your own designs on the Apple screen, at only **£29.95 + VAT** **STOP PRESS!**

Plus a complete range of "off the shelf" programs for finance, commercial, scientific and education. Keep yourself up to date, send for our "Fact Sheets" giving full program details.

## LEICESTER computer centre limited

109 QUEENS ROAD LEICESTER LE2 1TT  
Tel: 0533 709841

apple computer  
Sales and Service

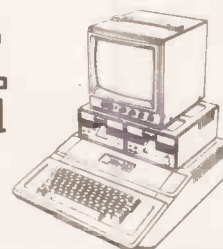

• Circle No. 324

# NEW THE TUSCAN S100

A Z80 based S100 Computer System.

TUSCAN main board. The heart of the system with Z80, video, Ram, Rom, and I/O plus five S100 slots for expansion.



A range of firmware options available.

Available in Kit Form or Assembled. All components available separately.

Houses two 5 1/4" drives for a compact business system

Professional case will house the complete system

Two keyboard options

Hinged lid for easy access

Stylish finish ideal for office or home.

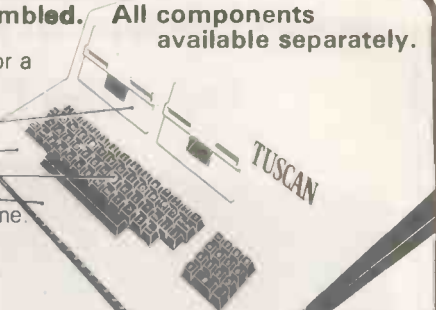

On Demonstration NOW

KITS from

£195 + VAT delivery Ex-Stock

**nascom-2**

**MICRO-KIT COMPUTER**

FREE 16k B RAM Board  
FREE POWER SUPPLY



Ex-stock only **£335** + VAT  
Full after sales service

**Firmware & MOS ICs**

Zeap Assembler (4, 1Kx8 EPROMS) £50

Nas Pen text editor (2, 1Kx8 EPROMS) £30

Expansion boards (in kit form)

16K RAM £127.50 • 32K RAM £175.00

48K RAM £220.00

High Resolution Programmable Graphics £90

Colour Board Kit £140

High Resolution Colour add on £37.50

## NASCOM PRODUCT LIST + VAT

I/O board kit less I/O chips	45.00
UART + BAUD rate generator + crystal for I/O board	16.00
Econographics kit for additional 128 characters (N1 only)	30.00
2708/2716 Programmer suitable for N1 and N2 under NAS-SYS	£20.95 plus VAT
Nascom 19" rack mounting card frame for N1 and N2	32.50
Nas-DA disassembler 3 EPROM for Nas-sys	37.50
MK36271 8K BASIC in 8K x 8 ROM	40.00
Naspen VS in 2 EPROM	30.00
Nas-sys monitor in 2 EPROM	25.00
Nasbug T2 1 x EPROM	12.50
Nasbug T4 2 x EPROM	25.00
Tiny Basic 2 x EPROM	25.00
Super Tiny Basic 3 x EPROM	37.50
Super Tiny Basic upgrade 1 x EPROM	12.50
<b>Tape Software</b>	
ZEAP 2 tape and documentation for Nas-sys	30.00
8K BASIC tape and documentation for N1	15.00

## THE HENELEC DISK SYSTEM

FOR NASCOM and any other Z80 - 8080 Microcomputer with an uncommitted P10



- The Henelec controller card plugs direct into a Z80 P10 and controls up to 3 double-sided mini-floppy drives giving a maximum 480K system.
- General Purpose FDC control software for simple DOS or for CPM.
- Simple DOS software for NASCOM 1/2 under NAS-SYS
- OR ROM CB10S for CPM on NASCOM 1/2 incorporating the major NAS-SYS features. Maximum 60K CPM system.
- New MD prom supplied for N2/CPM
- TWO SYSTEMS**
- SIM-DOS "Floppy Tape Recorder" with 1 drive PSU firmware, etc. £335 plus VAT
- CPM System with 1 drive PSU firmware, etc. £395 plus VAT
- Additional Drives with PSU £235 plus VAT

## COMPUTER KEYBOARDS



**71 KEY ASCII KEYBOARD INCLUDING NUMERIC KEYPAD.** £49.00 plus £7.35 VAT TOTAL £56.35. Uses gold crosspoint keys. Includes keypad and ribbon cable. Only available as fully assembled and tested.

**STAR DEVICES MK III 71 keytouch sensitive keyboard.** With numeric pad. All ASCII characters including control keys. Auto key repeat. Parallel output with strobe. Shift lock with indicator LED. Built in 'beeper' with level control. 5V DC at 300mA 15" x 7" x 1.25". Grey case with white keys on blue. 48.50 plus VAT.

**CARTER 57 key ASCII keyboard.** Conventional key board. 128 ASCII characters including control keys. Parallel output with strobe. Shift lock. + 5 V and -12 V DC. 12" x 5.5" x 1.5". Black keys with white legends. 39.34 + VAT.

**FERRANTI - "SIZE 14 x 6 x 3" SLOPING FRONT"** 55 Key ASCII Coded in steel case. Complete with Plug and Cable with circuit to convert to T.T.L. levels. In good condition at only **£25 + VAT, P/P £2.50**

# TANGERINE

COMPUTER SYSTEMS

"MICRON"

EX-STOCK

the latest line in superb products on demonstration from your London stockist

**£375.00** inc. VAT  
**BRITISH DESIGN**

- 6502 based microcomputer
- VDU alpha numeric display
- Powerful monitor TANBUG
- 8K RAM
- 32 parallel I/O lines
- 2 serial I/O lines
- RS 232 C/20mA loop, with 16 programmable Baud rates
- Four 16 Bit counter timers
- CUTS cassette recorder interface
- Data bus buffering
- Memory mapping control
- 71 Key ASCII Keyboard, including numeric keypad and with auto repeat
- Including metal cabinets for both keyboard and modules
- Including power supply
- 10K Microsoft BASIC

Ideal for NASCOM - PET - TRS80 - TRITON

**NASCOM IMP**



**PLAIN PAPER £325 PRINTER**

Fully built and housed in a stylish enclosure for just £325 plus VAT.

INTERFACES WITH ALL MICRO COMPUTERS

The Nascom IMP (Impact Matrix Printer) features are

- 60 lines per minute. 80 characters per line.
  - Bi-directional printing. • 10 line print buffer.
  - Automatic CR/LF. 96 character ASCII set (including upper/lower case, \$, £). • Accepts 8 1/2" paper (pressure feed). • Accepts 9 1/2" paper (tractor feed). • Tractor/pressure feed. Baud rate from 110 to 9600. • External signal for optional synchronisation of baud rate.
- IDEAL FOR WORD PROCESSING**

## CENTRONICS QUICK PRINTER

List Price **£459** incl. VAT



**OUR PRICE** plus VAT

**EXCLUSIVE TO HENRY'S 50% OFF MAKER'S PRICE £195**

for: Software selectable 20, 40 and 80 column using 120mm aluminium-ised paper. 1 roll supplied. 150 lines per minute. **NASCOM** Centronics parallel data interface for Nascom, Tandy, etc. 240 volt mains input. ASCII character set Paper feed, and on/off select switches 'BELL' signal Weight 10lbs Size: 13" x 10 1/2" x 4 1/2". New, boxed and fully guaranteed **POST PAID Price £195.00 + VAT** See **COMPUTING TODAY** Recommendations **MARCH/MAY ISSUES**

MEMORIES Discounts 10% for 4, 15% for 8, 20% for 16

MK3880 (N280)	7.50	2708	6.95
MK3880-N4 (Z80A1)	7.95	2716	17.95
MK4116 16K x 1 dy RAM	6.50	IM6402 UART	4.50
MK4027 4K x 1 dy RAM	2.25	2114 1K x 4 Static RAM	3.25
2102 1K x 1 static RAM	1.00	8080A	5.25
4118 1K x 8 static RAM	12.75		

# TANGERINE

LONDON STOCKISTS

Microtan 65 Kit, incl. VAT **£79.35**  
Microtan 65 Assembled, **£90.85**

Tanex (min. con) Kit, incl. VAT **£49.45**  
Tanex Assembled incl. VAT **£60.95**  
Lower case pack, incl. VAT **£10.90**  
Chunky Graphics Pack, incl. VAT **£7.50**  
20 Way Keypad incl. VAT **£11.50**  
Mini-mother board incl. VAT **£9.95**  
Complete Tangerine range available

SEND FOR COMPLETE COMPUTER BROCHURE FREEPOST TO ADDRESS BELOW

London Tangerine and TUSCAN  
NASCOM DISTRIBUTOR  
Export Orders deduct VAT, but add 5% carriage  
Official Export & Educational Orders welcome  
Our Telex 262284 Mono Ref. 1400 Transonics

ADD VAT  
15%  
TO YOUR  
ORDER  
EXCEPT  
WHERE  
STATED



# HENRY'S

Computer Kit Division  
404 Edgware Road, London, W2, England I.E.D.  
01-402 6822



## Erase Eproms in 8 minutes for under £100

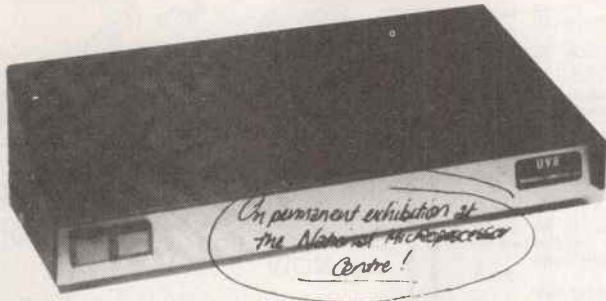

The high speed, high capacity model UV8 sets new performance and price standards.

- Cuts typical erasure times by a factor of 5
- 8 MINUTE SOLID STATE TIMER
- Capacity up to 14 EPROMS
- 2708 type erased in 4 to 7 minutes
- High intensity 254 NM UV source
- Safety interlock automatically starts timing sequence
- Audio tone signals erasure cycle complete
- Internal switch to extend erase time.

MICRODATA Computers Ltd, Belvedere Works, Bilton Way, Pump Lane Industrial Estate, Hayes, Middlesex.

Telephone (01) 848 9871 (6 lines) Telex 934110

## BUBBLE MEMORY and REAL TIME CLOCK for NASCOM

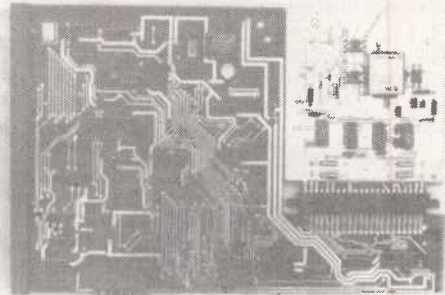

The 8423 is fully assemble, burnt in and plugs into the 77 way NASBUS.

- Add a non-volatile memory to your NASCOM I or II.
- Monitor transparent — use it with NAS-SYS, T2, T4 or B-BUG.
- Unaffected by dust or vibration.
- 92,304 bit capacity organised as 144 minor loops of 641 bits.
- Battery supported chosed clock generates perpetual day, date, time.
- Dealers enquiries welcomed.

**MICRODATA COMPUTERS LTD**  
BELVEDERE WORKS, BILTON WAY,  
PUMP LANE INDUSTRIAL ESTATE, HAYES,  
MIDDLESEX UB3 3ND

Telephone (01)-848 9871 (6 lines) Telex 934110

• Circle No. 326

# XITAN SYSTEMS

## CROMEMCO SYSTEM 3

£4,054.00 for this system with vdu.

The ideal business system. System includes a full 64K fast RAM, dual full-size floppies (Persci 277), RS232 interface/20ramp loop for console device, parallel printer port (Centronics/Anadex compatible), 21 slots for expansion, Lear Siesler 24 lines or 80 chars vdu, and ... CROMEMCO's CDOS operating system with their 14 digit BCD extended disk Basic — ideal for those accurate large numbers required by successful businesses. CDOS is CP/M functionally equivalent, with many extra facilities. Optional extras from Xitan include Fortran, Cobol, Text Formatting, Z-80 macro-relocating assembler and DBMS at £59.00 each, CIS interactive screen handling Cobol at £425.00 (recommended to serious business users), Cromemco S100 boards, CP/M (we are an authorised oem distributor of Digital Research's CP/M) for the System 3, Wordmaster, Wordstar, Supersort, and CPM374X utilities.

COMING SOON! ... Full 7-terminal multi-user operating system from Cromemco for System 3 users. Up to 48K per user, all running independently. This operating system has to be seen to be believed. It will run any of the Cromemco provided and supported software packages, in any combination. Features include partition rescue facilities, allocating more memory to users, real-time clock for time/date stamping of jobs and disk queueing techniques. Buy your System 3 now, expand later as you need it.

Xitan Systems also supplies and stocks vdus, printers, NORTH STAR HORIZON computers, Commodore Business Machines PETs, S100 boards, and books. We are here to demonstrate the range of quality microcomputer systems available for use today. Ring up for an appointment now! You'll not be disappointed. We have Osborne's Sales Ledger and Payable Ledger in source form for use on Cromemco System 3 with CBASIC2, and we can offer a customising service on these programs. Additional software includes Microsoft Basic Interpreter and Compilers, Cbasic, Macro80, and CP/M for the North Star Horizon.

**Xitan Systems Ltd., 23 Cumberland Place, Southampton SO1 2BB.**

**Tel: (0703) 38740**

**Hours Tue-Sat 9.30 am to 5.30 pm**

• Circle No. 327

# Solve your Business Energy Crisis

with a

## Z-Plus Microcomputer System

A state of the Art Microcomputer System. The first Multi-user Microcomputer to employ separate memory and CPU for each user.

The Modular design means you can upgrade the single user Z-plus Micro computer adding hard disk and additional Terminals as required.

Price: 1 Megabyte **£3950**,  
2 Megabyte **£4450** plus VAT

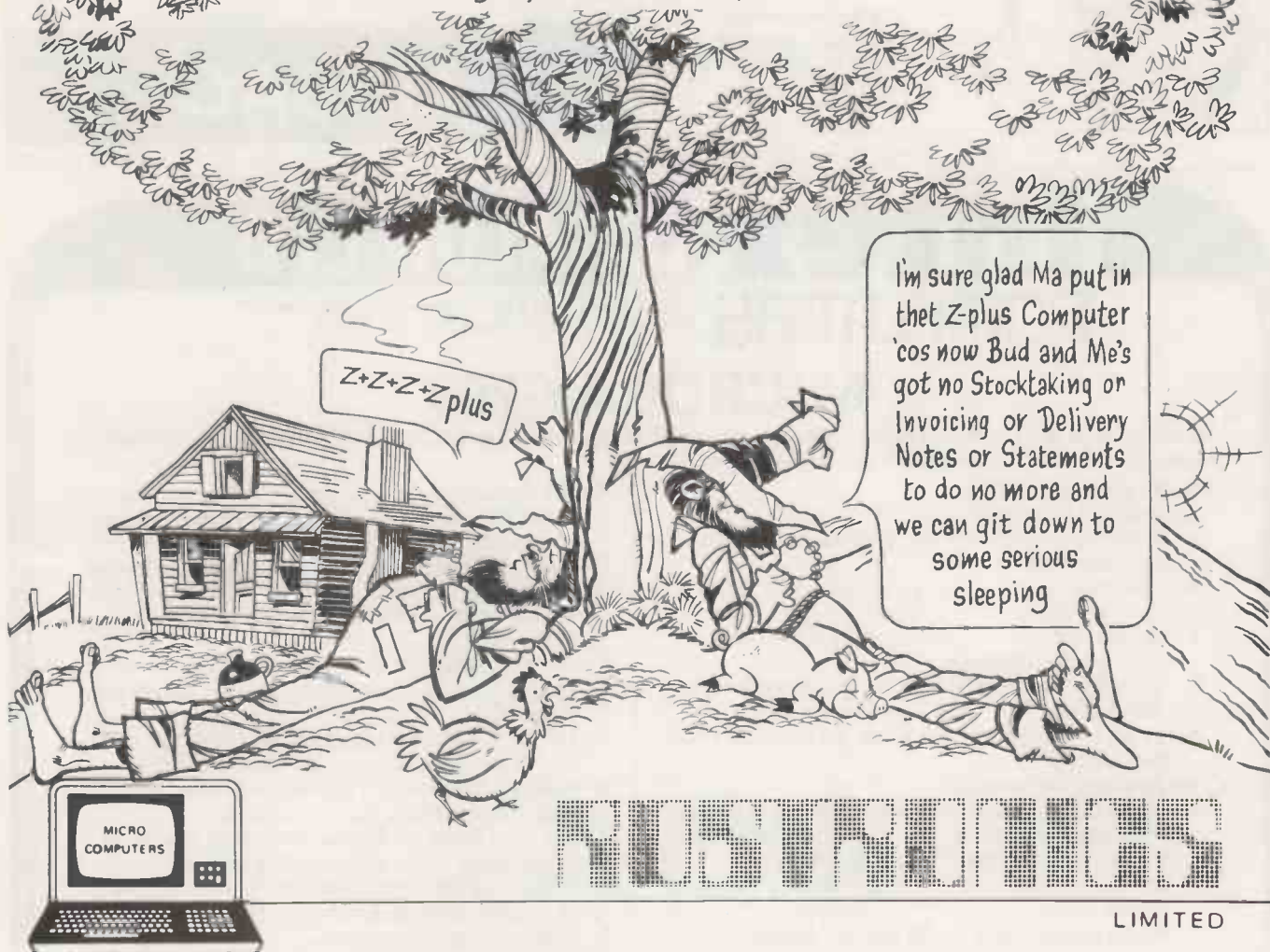

# ROBROTRONICS

LIMITED

The Z System is marketed throughout the U.K. & Europe and is available through a number of selected dealers.

115-117 WANDSWORTH HIGH STREET, LONDON SW18 4HY  
Telephone: 01-874 1171

Telex: 8813089 INTPRM G

• Circle No. 328

## Enter the Computer Age video genie system

12K MICROSOFT BASIC  
16K RAM, TV MODULATOR  
INTERNAL CASSETTE



**£330**  
+ VAT

**£395**  
+ VAT

80 Columns  
70 Lines per minute  
Graphics Characters  
Interfaces to most  
machines Tractor or  
friction feed



100's of programs available  
TRS-80 level II software  
compatible

Eley Electronics  
100/104 Beatrice Rd  
(Off Fosse Road North)  
Leicester  
Tel: 871522

• Circle No. 329

## THE ZX80 COMPANION

SECOND EDITION PRICE £10.00  
THE MONITOR REVEALED

This best-selling manual on the Sinclair ZX80 has now been extended to include a detailed explanation of the ZX80 monitor, routines and entry points, plus more programs. Send £10.00 cheque/P.O. to

LINSAC, 68 Barker Road, Linthorpe,  
Middlesbrough, Cleveland TS4 5ES

### SINCLAIR ZX80 SOFTWARE

Send S.A.E. for extended Autumn catalogue of lower-cost packages covering games, education and utility routines.

## LINSAC

• Circle No. 330

# Intex DATALOG LTD

## COMPUTERS

INTEX DATALOG LTD., Eaglescliffe Industrial Estate, Eaglescliffe, Stockton. Tel. 781193

### MICROPAY-200

Micropay-200 is a complete payroll System designed to run on a COMMODORE 32K PET microcomputer, interfaced to dual floppy disk drives and a printer.

#### The System provides:

1. Weekly/monthly payslips
2. Summary page of all payments and deductions that month
3. Summary page of all payments and deductions for the tax year to date
4. Weekly/monthly cash analysis slip for all cash payments made
5. Monthly summary of all payments and deductions
6. Year end summary of all payments and deductions

#### The System copes with:

1. Up to 200 current employees, plus end of the year details of up to a further 400 ex-employees who have left during the year
2. Suffix L,H,P,V and T cumulative and Week 1 Codes
3. Prefix D and prefix F, BR and NT codes

4. All necessary alterations concerned with changes in income tax rates, band widths and personal allowances
5. National Insurance Contributions at rates A, B and C for contracted out employees and at rates D and E for non-contracted out employees
6. All necessary alterations concerned with changes in N.I. contribution rates and earnings limits
7. UP to 5 user-definable wage rates for each employee, plus the normal hourly rate
8. Holiday pay — including a check on the amount of holiday taken in the year
9. Up to a total of 5 user-definable additions/deductions to the before/after tax pay
10. Changing an employee from one N.I. rate to another and backdating such a change
11. Job costing and analysis

# Intex

• Circle No. 331



# Introducing PEARL



Product of:  
Computer  
Pathways  
Unlimited, Inc.

**A Powerful Application Generator  
Produces Error-Free Automatic Rapid Logid  
Generates C BASIC 2 Programs and Compiles Them**

*Automatically Produces Programs For:*

Menu Selection	Level I	£90
File Update/Edit	Level II	£325
Report Generator	Level III	£625
Indexed File Reorganisation		
Indexed Access		

*All Prices Exclude V. A. T.*

Contact UK Distributer — Tel: 01-670 4202

Clenlo Computing Systems Ltd  
Crown House  
18 Gypsy Hill  
London SE19 1NL



## THE CLENLO CONQUEROR

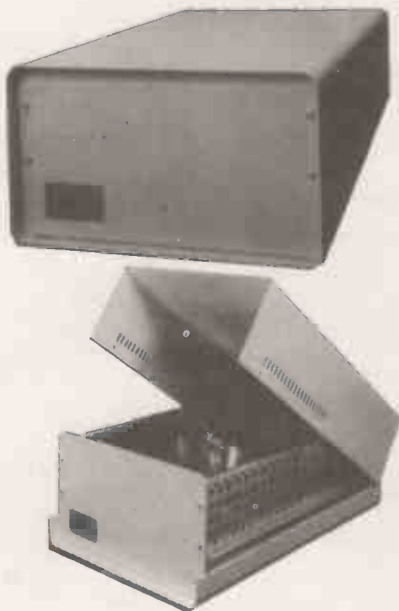

A Z-80 Microcomputer in an attractive Metal Cabinet, containing a 12 slot motherboard. Two serial and two parallel I/O ports are standard. Will accept a variety of S-100 compatible floppy and hard disc Drives.

16K RAM	650.00
32K RAM	805.00
48K RAM	960.00
64K RAM	1115.00

8" 500K Double Density Floppy Disc Drive and Controller.	700.00
Add On Unit	410.00

All prices exclude VAT

**Clenlo Computing  
Systems**



Crown House  
18 Gypsy Hill  
London SE19 1NL  
01-670 4202

# TRS-80 OWNERS GET MORE FROM YOUR COMPUTER

Now available in the UK — A magazine just for you

Published monthly MICRO-80 is full of programs and articles just for the TRS-80. Each month there is at least one applications program in Level 1 Basic, one in Level 2 Basic and one in Disk Basic (or Disk Compatible Level 2).

Get your complimentary copy by sending an A4 size stamped, addressed envelope to:

MICRO-80 (UK Subscription Dept.),  
24 WOODHILL PARK, PEMBURY,  
TUNBRIDGE WELLS, KENT TN2 4NW.

**BUT HURRY — THIS OFFER MUST BE LIMITED  
TO THE FIRST 500 APPLICANTS**

• Circle No. 333



**Digital  
Design &  
Development**

**THE  
INTERFACE  
SPECIALISTS**

Duchess House 18-19 Warren Street  
London W1P 5DB Tel: 01-387-7388

#### PET INTERFACES

- 16-CHANNEL 8-BIT A-D CONVERTOR UNIT  
IEEE-488 Compatible. PRICE: £300
- 8-CHANNEL 8-BIT D-A CONVERTOR UNIT  
IEEE-488 Compatible. PRICE: £350
- 16-CHANNEL RELAY UNIT  
IEEE-488 Compatible. PRICE: £350
- USER PORT CONVERTOR (A-D & D-A)  
Single channels IN & OUT. PRICE: £200
- X-Y ANALOG PLOTTER INTERFACE  
IEEE-488 Compatible. PRICE: £200
- 8-CHANNEL 12-BIT A-D CONVERTOR UNIT  
IEEE-488 Compatible. PRICE: £600
- 8-CHANNEL DIGITAL DATA INPUT UNIT  
IEEE-488 — 64 bits IN. PRICE: £400
- 8-CHANNEL DIGITAL DATA OUTPUT UNIT  
IEEE-48 — 64 bits OUT. PRICE: £350
- FAST DATA ACQUISITION SYSTEM  
40,000 readings per sec. 4 A/D + 4 D/A  
PRICE ON APPLICATION

All units boxed complete with IEEE-48 address internally selectable, with integral power supply, cables, switch, fuse, indicators and illustrative BASIC software.



#### SHARP MZ-80K INTERFACES

- PARALLEL PRINTER INTERFACE. PRICE: £110
- SERIAL PRINTER INTERFACE. PRICE: £150
- BIDIRECTIONAL SERIAL INTERFACE. PRICE: £210
- 16-CHANNEL A-D CONVERTOR UNIT. PRICE: £280
- FAST DATA ACQUISITION SYSTEM — 40,000 readings/sec. 4 analog channels IN & 4 channels OUT. PRICE ON APPLICATION

#### SHARP MZ-80K SOFTWARE

- AIR ATTACK — Bomb the buildings to land successfully — £5
- ANIMAL — Learning program distinguishes between different creatures — £5
- CARD TRICK + ONE ARM BANDIT + LISSAJOU  
Ingenious mixed bag — £5
- MACHINE LANGUAGE HANDLER (T20C) — £22.50
- EDITOR-ASSEMBLER + LOADER + DEBUGGER — £45.00

*\*Phone or write for further information.*

**TERMS** All prices EX-VAT. P&P extra. Cheques should be made payable to 3D Digital Design & Development. All goods supplied under 90 days warranty.

**CUSTOM DESIGN UNDERTAKEN**

• Circle No. 334

# MITSUI IS LAUNCHING A VARIETY OF PRODUCTS FOR OEM CUSTOMERS AT COMPEC '80

## ALPS DESK-TOP COMPUTER

Fully integrated computing power in a compact boxed unit comprising

- Z-80 4MHz CPU
- 64KB RAM + 2KB ROM
- Dual 5 1/4 inch double-sided double-density mini-floppies (437.5 KB/drive) or Dual 8 inch double-sided double-density floppies (1 MB/drive)
- 8 inch Winchester discs with maximum 40MB storage also available
- 12 inch CRT display with 80 x 25 characters. 128 kinds of characters and 160 x 100 dot graphics
- Fully Detachable Keyboard
- 80 column 120 cps integral printer or 132 column 180 cps printer for further versatility
- RS-232C 2 ports + optional 6 ports
- Asynchronous or synchronous communication
- Magnetic card reader available
- ADOS multi-task operating system
- BASIC, Extended BASIC + PASCAL, COBOL, FORTRAN, MACRO ASSEMBLER, IBM 2780/3780 Emulator

## 3Q CRT DISPLAY

- 3", 5.5", 9", 10", 12", 14" and 15" screens available
- Phosphor selectable from P4, P31, P39 and P42
- Brilliant, high-resolution, high-stability display, free from distortion
- More than 10,000 hours MTBF ensures high reliability (excluding CRT)
- Easy maintenance and inspection
- Separate 3 signal input or composite signal input
- DC or AC power inlet
- 15" extra high resolution 6,000 character full page display unit and 14" high resolution 3,960 character colour CRT display unit also available

### HOKUSHIN-DIABLO DAISY WHEEL PRINTER

- 45 cps high quality print-out
- Wide choice of 96 character set plastic print wheel
- 132 columns at 10 pitch/ 158 columns at 12 pitch
- 120 positions per inch horizontal and 48 positions per inch vertical spacing
- High reliability obtained from combination of excellent American design and Japanese craftsmanship

### HP 1600 SERIES HYTERM PRINTER TERMINAL

- High quality Hokushin-Diablo HyType II printer mechanism
  - With keyboard (KSR) or without keyboard (RO)
  - RS232C interface
  - 110/150/300 Baud switch selectable
  - Half or full duplex
  - Graphic versatility
- These printers are manufactured under license from Diablo Systems Inc.

MITSUI is the sole U.K. distributor for Alps desktop computer; Hokushin printers and magnetic discs, 3Q CRT displays, TOTEC optical character readers and CASIO facsimile Group II units.

Come and see us on Stand 9046 at Compec '80 Olympia, London, November 4, 5, 6 or write for further information.

## MITSUI MACHINERY SALES (U.K.) LTD

ELECTRONICS DEPT.  
OAKCROFT ROAD, CHESSINGTON  
SURREY KT9 1SA  
TEL: 01-397 5111

# INTEGRATED SMALL BUSINESS SOFTWARE ISBS

**GRAFFCOM  
SYSTEMS GROUP**

## ISBS MODULES

- **PAYROLL** Standard PAYE/HMI Taxes routines, 250 employees, weekly or monthly, cash, cheque or bank giro, cumulative YTD figures, employee lists, payroll logs, pay slips and giro slips.
- **COMPANY SALES** Complete sales accounting, invoice control & analysis, sales ledger, aged debtors reports, statements, VAT control, variable accounting periods, credit control and customer maintenance.
- **COMPANY PURCHASES** Complete purchase accounting, invoice control analysis, purchase ledger, aged creditors reports, payment advices, Vat control, variable accounting periods.
- **STOCK CONTROL** Maintains stock records, monitors stock levels for optimisation. Stock descriptions, codes, unit prices, selling prices quantity on hand/min/on order/re-order/allocated/unsatisfied, analysis reports, price lists, parts explosion.
- **ORDER ENTRY & INVOICING** Invoices for services and consumable items, part orders or part quantities, sales analysis reports showing movements and trends over user defined periods.
- **GENERAL ACCOUNTING** Nominal ledger, trial balance, profit & loss, balance sheet, user defined cost coding system and accounting periods.
- **NAME & ADDRESS** Complete control of names & addresses, user defined coding system, report generator produces selective reports, prints anything from mailing labels to directories.

Designed for most of the popular 8080/Z80 Microcomputer disk systems running under CP/M\*. Requires 48K memory, dual floppy disks (or large fixed disk system), VDU and 132 col printer.  
GRAFFCOM SYSTEMS LTD, 52 SHAFTESBURY AVENUE,  
LONDON W1. 01-734 8862.

\*CP/M is a trademark of Digital Research.

• Circle No. 336

# Does your microcomputer suffer from hiccups?

If so, quite often the cause of irregular performance or breakdown is very simple.

It's probably a high voltage spike in the electricity supply, called a transient, affecting the performance. Heavy electrical loads in the vicinity of your microcomputer (from domestic electrical appliances to office photo-copiers) can often cause voltage transients, which in turn, play havoc with both hardware and software.

The Reguvolt 'P' Model Constant Voltage Transformer provides the answer to a very simple yet aggravating problem, offering the following benefits to safeguard your supply sensitive computer and equipment.

- Transient suppression — gives software and hardware protection.
- Brownout protection — prevents micro interruptions and system crashes.
- Isolated secondary circuitry — gives complete electrical isolation between mains and computer.
- Fast voltage stabilisation — prevents VDU screen drift and complete system failure.



- Automatic overload current limited — protects equipment against damage during a fault condition.
- Low frequency mains harmonics removed, preventing VDU flicker and circuit overload.

The complete range of Reguvolt 'P' models, from 1/2 to 2 amp ratings (ie. 120VA to 500VA) are available from stock.

Should you require further details, please fill in the coupon, or, if you prefer, give us a call.



**Cetronic Limited**

Hoddesdon Road Stanstead Abbots,  
Ware Herts SG12 8EJ England

Telex Ware (0920) 871077 Telex 817293

SEE US  
AT  
COMPEC '80  
STAND  
1180

Please send me further information on your range of Reguvolt 'P' Model Constant Voltage Transformers.

Name .....

Company .....

Address .....

Telephone .....

• Circle No. 337

PRACTICAL COMPUTING November 1980

**THE LEADING EXHIBITION OF  
COMPUTERS, PERIPHERALS  
AND SYSTEMS**

**COMPEX**  
**'80**

will be in the Grand Hall  
**OLYMPIA, LONDON**  
November 4, 5 & 6, 1980

**CAN YOU AFFORD  
TO MISS  
BRITAIN'S BIGGEST  
COMPUTER  
EXHIBITION?**

**TRADE ONLY – NO SCHOOL PARTIES – NO ADMITTANCE UNDER 16  
ENTRANCE £2**

Sponsored by "Computer Weekly," "Data Processing," "Practical Computing" and  
"Systems International" and with the support of "Electronics Weekly" –  
all members of IPC Business Press, the worlds largest publisher of specialist and  
business journals.

Peripherals from  
Penny & Giles

Now there are two Lear Siegler Dumb Terminals. The same reliable ADM-3A with loads of dependable features – 12in screen, full/half duplex, 11 selectable data rates, 1920 characters in 24 rows of 80 letters, RS232C port and direct cursor addressing.

And the new reliable ADM-3A+ for those who need something extra, like, numeric pad with full point, comma, tab, minus and return, upper and lower case caps lock, programme mode key and separate cursor control key. Both on immediate delivery.

**ADM-3A**  
end user price £481

**ADM-3A+**  
end user price £533



## printers



### Penny & Giles hard copier

An electro-static, micro processor controlled, line or message printer, with graphics facility, serial or parallel interfacing, re-programmable character generator and add-on user programmable options.

end user price £423

### Penny & Giles matrix printers

A plain paper, programmable printer with 8080 intelligence, 80 columns, bi-directional print speed of 55 to 1000 lines per minute depending on format, multiple character set and a graphics option.

end user price £806



## data stores



Penny & Giles minifile is the compact floppy disc data store with all the performance you will need:  
rapid access to 600 files per disc  
up to 162 thousand stored characters  
full integral disc management

up to 7200 baud transfer rate  
automatic error handling  
RS232/tele type compatible interface  
auxiliary modem port

And it has dual disc expandability and full edit too, if you need it.  
end user price – single disc £943

Get full technical details on all the peripherals from Penny & Giles by ringing the reader service number.

**Penny & Giles**  
Data Recorders Ltd



Mudford Christchurch Dorset BH23 4AT  
Tel: Highcliffe (042 52) 71511 Telex: 41266

• Circle No. 338

## FINANCIAL ACCOUNTING SYSTEMS

For the Commodore PET Computer

Comprising:

- 1: Sales Ledger
- 2: Purchase Ledger
- 3: Nominal Ledger
- 4: Open Item Sales Ledger
- 5: Open Item Purchase Ledger
- 6: Open Item Nominal Ledger
- 7: Integrated Sales, Purchase & Nominal Ledgers
- 8: Integrated Open Item Sales, Purchase & Nominal Ledgers
- 9: Budgets Within Nominal Ledgers (3, 6, 7 and 8)
- 10: Invoicing & Analysis Integrated with Sales Ledger (1, 4, 7 & 8)
- 11: Stock Recording Integrated with Invoicing and Analysis

\*\* Note Requires 32k Computer, 3040 Disk Drive & Printer  
\*\*\*\* Sensibly Priced Software for the Commodore PET \*\*\*\*

### SOFTWARE LICENCE FEES

Systems 1. to 6. £90.00 + vat each  
Add-ons 7. to 9. £50.00 + vat each  
Add-on 10. £100.00 + vat  
Add-on 11. £150.00 + vat

Pre-Printed Stationery Available

Send for System Specifications and Sample Printout



**THISTLE COMPUTERS**  
39 ALBERT STREET  
KIRKWALL  
KW15 1HQ  
(0856) 3140

And at The Square, Beauly, Inverness.

\*\* We also supply the hardware for the above systems \*\*

• Circle No. 339

**BEAVER**  
SYSTEMS



Norlett House  
Dormer Road  
Thame  
Oxon OX9 3UC  
Telephone Thame  
(084421) 5020 (24 hr)

## YOUR COMPLETE OHIO SCIENTIFIC SERVICE

HERE ARE FIVE VERY GOOD REASONS FOR CALLING US –

### 1. O.S.I. SYSTEMS

– including the popular SUPERBOARD II and CHALLENGER 4P as either cassette or disc based systems.

### 2. O.S.I. SOFTWARE

– cassette and disk based software covering a broad spectrum of uses. Some of the cassette based software can also be run on the U.K.101.

### 3. BEAVER SOFTWARE

– Business, educational and entertainment software – professional programs with full listings and documentation. Also available for other systems – especially the U.K.101.

### 4. BEAVER PROGRAMMING AIDS

– including Video Workpads, BASIC workpads, Machine Code Workpads, Cassette Index cards and labels and Blank Cassettes, all available for OSI, U.K.101, and TRS-80.

### 5. BEAVER EXPANSION

– Economy memory expansion using motherboard and slot-in 8K RAM boards, 8K EPROM boards, floppy control board & shortly, PROM Programmer board. Buy as much as you need when you need it.



**CALL OR WRITE ... NOW!**



• Circle No. 340

# Important announcement

Manchester — the birthplace of the British computer is to stage the most significant computer event ever to be held in the North of England.

# MANCHESTER MICRO SHOW

**Three Day Exhibition & Seminars**  
New Century Hall and  
the National Computing Centre

Exhibitors at the Mersey Micro Show have already taken up many of the options offered — please contact Jane Windeler at the Online offices who will reserve your company a stand awaiting your written confirmation.

*online*

Online Conferences Ltd.  
Argyle House Northwood Hills Middx. HA6 1TS.  
Tel: (09274) 28211



• Circle No. 341

# ROCKWELL AIM 65 MICROCOMPUTER

## FEATURING

- 20 Column hard copy printer
- 20 Character alphanumeric display
- 54 key full size alphanumeric keyboard
- 1 MHz 6502 microprocessor
- Full — bus system expansion connector
- Plug in sockets for 4K RAM
- Plug in sockets for 20K ROM
- Symbolic Assembler firmware
- Advanced Interactive Monitor firmware
- 44 Pin systems applications connector

Code	Product	£ ex VAT	
A65-100	AIM65 with 1K Static RAM	232.00	
A65-400	AIM65 with 4K Static RAM	275.00	
A65-010	Assembler ROM for AIM65	50.00	
A65-020	BASIC Interpreter ROMs for AIM65	58.00	
A65-009	AIM65 Expansion motherboard	105.00	
A65-081	R6500/1 Personality module 1MHz	735.00	
A65-030	PL/65 Compiler for AIM65	81.00	
A65-410	AIM65 with 4K RAM and Assembler ROM	309.00	
A65-415	AIM65 with 4K RAM and BASIC ROMs	319.00	
A65-420	AIM65 with 4K RAM Assembler ROM and BASIC ROMs	345.00	
A65-901	PROM Programmer and CO-ED	155.00	
PSA65	Power supply for AIM65	48.00	
CM14	14" Colour monitor (RGB input)	250.00	
CV01	Optional composite video D/B	30.00	
SU01	RGB Sync to UHF Colour (625) converter	50.00	

The following product ranges are available.

- Rockwell R6500 NMOS microprocessors.
- Rockwell AIM65 Microflex Expansion boards.
- Rockwell PPS PMOS Microprocessors.
- Rockwell PPS PMOS Microprocessor family support equipment.
- Rockwell Bubble Memory products.

Mullard Teletext Integrated Circuits.

SAA5000	2.90
SAA5010	6.13

SAA5020	5.33
SAA5030	8.26
SAA5040	15.14
SAA5050	8.51

Mullard Teletext/Viewdata Modules.

VM6101 Teletext only	75.00
VM6230 Teletext/Viewdata	104.32
VM6330 Acquisition/Control	114.10
VM6430 Line Coupling Unit	164.63

## DATATEX (MCLELLAND) LTD

Unit 3A, Bankfield Industrial Estate,  
Kitson Road,  
Leeds LS10 3YY.  
Telephone 0532 455169  
Telex 556282

9 Annandale Street,  
Edinburgh EH7 4AW.  
Telephone 031 556 5481  
Telex 727424

• Circle No. 342

# TAKE A TEST DRIVE AND DEMONSTRATE TO YOURSELF WHY YE DATA IS JAPAN'S TOP SELLING DISKETTE DRIVE.



Only in action can the YE Data diskette drive prove its quality and reliability. We invite you, with no obligation whatsoever, to evaluate one in your own test environment.

We're confident that having put one on test, you'll join the growing number of world wide OEMs that now specify YE Data diskette drives.

Well proven in the field, showing a MTBF of 10,000 hours, the range features the following:-

- 8" IBM or 5 1/4" ANSI and Shugart model compatible versions.
- double sided, single or double density.
- access times from 3mS track to track.
- capacities to 1.2m bytes per disk formatted.

Immediately available with full support and nationwide service from the OEM division of DRG Business Machines, Lynx Crescent, Winterstoke Road, Weston-super-Mare, Avon BS24 9DN. (Tel: 0934 415398).

**DRG Business Machines** A Dickinson Robinson Group Company

<input type="checkbox"/> I would like to test a YE Data drive. Please contact me.	<input type="checkbox"/> Please send me more information
Name _____	Position _____
Company _____	
Address _____	
Type of Business _____	Tel: _____ PC11

**TALK TO DRG ABOUT YE DATA**

• Circle No. 343



# TCL PASCAL

Standard PASCAL  
with P-code interpreter and linker,  
following the ISO/BSI working draft.  
Compiler operates in two modes:

Resident in RAM — makes  
PASCAL as easy to learn as BASIC  
Disc mode — with full set of  
PASCAL commands.

Many enhancements to standard  
PASCAL. Fully validated. Runs in  
32K of RAM.

- TCL PASCAL for CP/M and PET is available now  
at £120 plus VAT including Manual. Carriage paid.
- TCL PASCAL Manuals are available at £9.50 each.  
Carriage paid.

## TCL SOFTWARE

*We mind our language!*

TCL SOFTWARE  
59/61 THEOBALD'S ROAD, LONDON WC1.  
TEL: 01-405 5240

©TCL PASCAL is copyright of TCL Software. OEM licences available.

®  
CP/M

Compatible with all  
systems. IBM format on 5"  
or 8" discs.  
Manual — TCL PASCAL  
for CP/M.  
Runs on TUSCAN,  
TRITON, 380Z, TEI, TRS80  
computers.

\*  
PET

Unique features include  
interface to PET BASIC and  
clock.  
Available now for PET 3032  
on 5" disc.  
Manual — TCL PASCAL  
for PET.

*\* Available from TCL SOFTWARE and all Commodore  
PET dealers now.*

I am interested in the TCL PASCAL compiler. Please send me:

- The TCL PASCAL Manual for PET CP/M\* at £9.50  
 The TCL PASCAL Manual and DISC for PET CP/M\* at £138.  
\*Delete as necessary and specify 5" or 8" disc for CP/M.

NAME \_\_\_\_\_

ADDRESS \_\_\_\_\_

TELEPHONE \_\_\_\_\_

PC11

• Circle No. 344

# The Strong Silent Type



- Line printer quality at character printer price.
- 300 lines per minute.
- Serial or parallel interface.
- Centronics or Dataproducts Compatible.
- Electronic Vertical Forms Control.
- Highly efficient sound reducing cabinet.

OEM PRINTERS FROM

## KODE

Station Road, Calne, Wiltshire SN11 0JR.  
Telephone Calne (0249) 813771. Telex 449335

• Circle No. 345

## The Rohan Computing Collection.....

Rohan computing, in addition to their normal software and systems consultancy services, now offer the following range of computer equipment for sale. As far as possible Rohan computing try to hold these items in stock ready for immediate delivery. Nationwide on site maintenance for all Rohan computing equipment.

**Qume** The Qume is ideal as a general purpose printer or for adding word processing facilities to an existing micro-computer. Print only and keyboard versions available. The keyboard version can double as a spare typewriter. RS232 interface adaptable for the PET, APPLE, etc. XON/XOFF protocol available. Word processing package/driver available for CP/M based systems. Other versions in preparation.

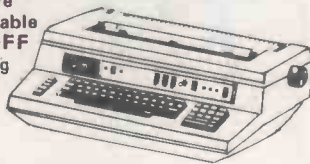

**digital** Digital Decwriter IV. The best desk top matrix printing terminal available. Typewriter styling. 10,12,13,2,16.5 characters per inch. All sizes very legible. 2,3,4,6,8,12 lines per inch. Optional tractor feed and numeric keypad. RS 232 interface.

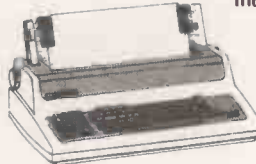

**PET** Commodore PET microcomputers. The PET is the ideal low cost computer for teaching yourself programming, educational use and time consuming calculations in science, industry and commerce. Graphic display excellent for histograms etc.  
\*8k PET with integral cassette and minikeyboard  
\*16 & 32k PET's with full sized professional keyboards.  
\*2022 matrix printers  
\*2040 floppy disc units.



**CIFER** Cifer 2600 Series VDU's. Superbly engineered and made in Britain. \*12 inch screen.  
\*7 x 11 character matrix  
\*9 x 12 matrix for graphic characters  
\*62 or 100 key detachable keyboards  
\*Printer port  
\*VT52 emulation  
\*Line drawing set



\*RAIR Blackbox, Teletype 43s, Tally high speed matrix printers also available.\*

# Rohan

Phone Richard on SOUTHAM (092681) 3541 for prices and delivery.

Rohan Computing, B.A.S.S. (Engineers) Sales Limited, Kineton Road, Southam, Warwickshire CV33 0DO

• Circle No. 346

# SUPERBRAIN™ PLUS

INTERTEC DATA SYSTEMS\* INTRODUCED THE REMARKABLE SUPERBRAIN AT THE START OF 1980

now ENCOTEL SYSTEMS LTD.  
introduces SUPERBRAIN +

## ALL THE STANDARD FEATURES

- \* 64K RAM \* DUAL Z80 A's \*
- \* DUAL RS-232 COMMUNICATIONS PORTS\*
- \* CP/M 2.2 OPERATING SYSTEM \*

- + 800K DISC CAPACITY STANDARD (STD QD M/C 700K)
- + 1.6 MB OPTIONAL
- + FAST DISC ACCESS — FIVE TIMES FASTER THAN STANDARD MACHINES
- + KEY REPEAT
- + BACKGROUND COMMUNICATIONS FACILITY
- + OPTIONAL TELEX BOARD

## AND NEW LOW PRICES

SUPERBRAIN +	800K	£2150
	1600K	£2550
* HARD DISCS	10MB	£2640
	32MB	£7900
	96MB	£9900

\* (allows up to 255 COMPUSTAR users)  
6 month warranty — 1 years maintenance agreement £200



## \*\* SOFTWARE \*\*

THE BEST RANGE OF SOFTWARE

- new
- \* 6502/6800/8080/8085/Z80 ASSEMBLER
  - \* 8048 ASSEMBLER
  - \* THE CREATOR BASIC PROGRAM WRITER
  - \* THE REPORTER BASIC FILE REPORTER
  - \* SPLITBINDER WORD PROCESSING
  - \* Demonstrable IBM 3740 EMULATOR (3270 soon)
  - \* A DBMS WHICH SURPASSES CODASYL DBMS REQUIREMENTS
  - \* GRAHAM DORIAN BUSINESS SOFTWARE
  - \* BASIC, COBOL, FORTRAN, PL I, PASCAL (API soon)
  - \* DATA ENTRY SYSTEM AND DATA ENTRY TOOL, £75 EACH
  - \* ASYNC TERMINAL SOFTWARE £75

## WHY ARE SO MANY LARGE COMPANIES COMING TO US?

because WE OFFER fast DELIVERY, PROFESSIONAL SERVICE  
IBM COMMUNICATIONS EMULATORS, SOUND ENGINEERING AND  
SOFTWARE EXPERIENCE, COMPETITIVE PRICES and backup

Remember  
SUPERBRAIN +

IS ONLY AVAILABLE FROM THE ENCOTEL DEALER GROUP

TERODEC MICROSYSTEMS LTD  
BOYD MICROSYSTEMS LTD  
MAP COMPUTERS LTD  
MAP COMPUTERS LTD  
MAP COMPUTERS LTD  
PICTODYTE LTD  
SYSTEMS MICROS LTD  
MICROMANAGEMENT LTD  
REVALE COMPUTERS LTD

Camberley, Surrey  
Bushley Heath, Herts  
Oldham, Lancs  
Leeds  
Glasgow  
Birmingham  
Telford, Staffs  
Ipswich, Suffolk  
Bury St Edmonds, Suffolk

(0252) 874790  
(01) 950 0303  
(061) 633 3084  
(0532) 445234  
(041) 204 1297  
(021) 328 4840  
(0952) 460 214  
(0473) 4592  
(095181) 316

WORKFLOW LTD  
D D M LTD  
ENSIGN LTD  
KING PIN COMPUTERS LTD  
ISIS COMPUTER SERVICES LTD  
NICOMTECH LTD  
ORCHARD MICROBYTE LTD  
BUSINESS CONTROL & DEVELOPMENT  
LABTRONICS LTD

Cowden, Kent  
Brentwood, Essex  
Swindon, Wiltshire  
Stevenage, Herts  
Henley on Thames, Oxon  
Saltash, Cornwall  
Rayleigh, Essex  
Cheltenham, Glos  
Sevenoaks, Kent  
(034286) 357  
(0277) 224 379  
(0793) 42615  
(0438) 59677  
(04912) 77735  
(07555) 2066  
(0268) 741271  
Evesham (0386) 831969  
Orford (09592) 2872

COME & SEE US AT THE WHICH COMPUTER SHOW (STAND 234 — NOV 26-28)

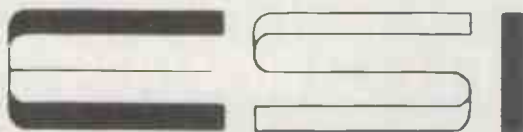

**Encotel Systems Ltd**

Showroom at Croydon, Surrey

Telephone: Upper Warlingham 5701

Telex: 896559

\* WE ARE OFFICAL INTERTEC DISTRIBUTORS \*

• Circle No. 347

# Chaljo Computers

Limited

COST-EFFECTIVE BUSINESS SYSTEMS

## APPLICATIONS

Production Control  Stock Control

Sales Ledger  Purchases Ledger

Nominal Ledger  Payroll

Word Processing

## FEATURES

- \*Proven software.
- \*Applications may be free standing or totally integrated.
- \*Flexibility in configuration.
- \*The system will work on floppy disks and hard disks.
- \*Additional VDU's and printers require no reprogramming.
- \*Fast delivery of total system.

For your FREE SURVEY contact:

**Mike Lynn**

55-57 Station Road, Edgware,  
Middlesex HA8 7LJ.  
Telephone: 01-346 8938

• Circle No. 348

# computerkit

a new concept in  
computer control

built on peripheral highway

apple and other interfaces  
from £120

digital controller      analog controller  
from £150

relays from £10

digital sensors      analog sensors  
from £10

all you need for control application  
in the laboratory, home, and industry

dealer enquiries welcome

BUSINESS COMPUTER SERVICES  
POLLARDS FARMHOUSE, CLANVILLE  
NR. ANDOVER, HAMPSHIRE  
TELEPHONE 026470300

• Circle No. 349

# MONITORS MONITORS MONITORS

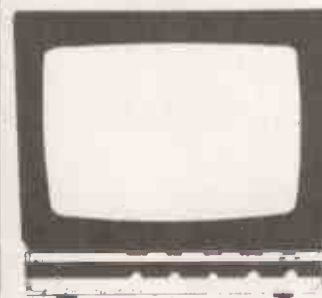

UNCASED 9"

UNCASED 12"

CASED 9"

CASED 10"

CASED 12"

MONITOR TUBES

SELF CONTAINED MONITOR PCB's

## CROFTON ELECTRONICS

Crofton Electronics Limited  
35 Grosvenor Road, Twickenham, Middlesex.  
Tel: 01 891 1513

• Circle No. 350

# MICROMAS

is now also available  
on Superbrain



The **MICROMAS**  
complete, *integrated*, business  
accounting system comprises:  
A NOMINAL LEDGER linked to  
Stock Control  
Invoicing  
Sales Ledger  
Purchase Ledger  
Payroll  
Management Accounts  
Mailing  
Time Recording

For use as a complete system or in module form for any CP/M with Microsoft BASIC or North Star BASIC from a European and nationwide dealer network trained in system implementation.

**MICROMAS** is currently available on the following:

Altos  
Dynabyte  
H.E.A. 3000

I.M.S. Series  
North Star Horizon  
Vectorgraphic



Contact us for your nearest dealer.

**P. R. Daly & Co. Limited**

*Systems Consultants*

Oaklands Gate, Northwood, Middx.  
Tel. Northwood (09274) 29815 or (01) 868 7284

# Conquer the Computer

Learn to really understand the Computer. How it works and operates. Its 'language'.

How to program it and make full use of its capabilities.



- No previous knowledge necessary.
- Special educational Mini-Computer supplied ready for use.
- Complete home study library.
- Self-test program exercises.
- Complete programming instructions using computer.
- Services of skilled tutor available.

Please send details without obligation to:—

Name .....

Address .....

BLOCK CAPS PLEASE

**BRITISH NATIONAL RADIO & ELECTRONICS SCHOOL**  
4 Cleveland Road, St. Helier, Jersey, Channel Islands. PC11

• Circle No. 352

# New from Millbank!

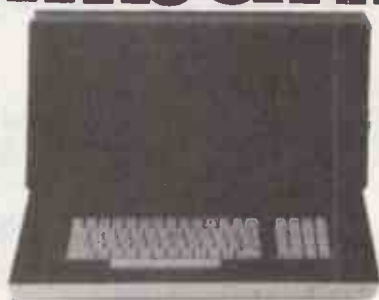

## SYSTEM 10

List every important feature you would like to see on a small business computer -- then add "compact, reliable, portable, easy to use and guaranteed for one year"

SYSTEM 10 a real Giantkiller at £2995.00 (excl. VAT)

Ring or write for details and don't forget to ask about our amazing new prices for:—

## Qume Sprint 5 Printers.

high quality 45/55 KSR and RO Daisywheel Printers.

**MILLBANK COMPUTERS LIMITED**

98 Lower Richmond Road, London SW15 1LN.  
Telephone: 01-788 1083

• Circle No. 354

## MICRO SPEECH 2 DOES YOUR COMPUTER SPEAK TO YOU?

MICROSPEECH 2 is a stand alone speech synthesizing unit. It converts phonetic code or any ASCII text into a speech output. MICROSPEECH 2 may be interfaced to any computer system because all the computation necessary to synthesize speech is performed by its own dedicated microprocessor. Up to one thousand phonetic characters, representing about one minute of speech, may be assembled in the units internal buffer before it is commanded to speak.

### FEATURES

- Runs from phonetic code, giving unlimited vocabulary and simple operating software.
- Optional English to phonetics translator allows operation directly from ordinary text.
- Uses standard RS232C/V24 interface.
- Totally self contained with internal loudspeaker and power supply.
- No need to worry about complex interfacing or support software.



### PRICE

Phonetic model £875.00 + VAT

Phonetic model plus English to phonetics translator ..... £950.00 + VAT

Available from:

**COSTRONICS ELECTRONICS** 13 Field Heath Avenue,  
Hillingdon, Middlesex Uxbridge (89) 38791  
**TIM ORR DESIGN CONSULTANT**  
55 Drive Mansions, Fulham Rd, London SW6  
(01) 7312077

• Circle No. 353

# MICRO-FACILITIES

127 HIGH STREET  
HAMPTON HILL  
MIDDLESEX

**01-979 4546**

**01-941 1197**

## MIDDLESEX & S.W.LONDON

Approved Business Dealers for:

Commodore Computers & Business Packages  
Apple II  
North Star Horizon  
IMS 5000/8000 Series

As fully authorised Dealers for the above equipment, and as experienced data processing professionals, we are the best people to help you.

Our complete package offers you:

Free initial discussion & advice  
Systems Design & Programming  
Software Packages  
Supply & Installation of equipment  
Leasing & Financing terms  
Full Maintenance Contracts  
Genuine After Sales Service

Contact us to discuss your problems and requirements, we offer you a lot more, but only charge the same. Our ability will give you peace of mind and confidence that the job will be done properly.

• Circle No. 355

## TRS-80 owners!! Double Disk Capacity with the Phantom Double-Density Module

Provides double density modification to your current TRS-80 Expansion interface

Increases storage capacity up to 204K bytes (on single 40 track drive.)

Includes all hardware and software.

**£165**



## Load TRS-80 programmes & data Fast!

with the Phantom  
Disk Drive system

\*23% more storage capacity than TRS-80  
\*40 track patch at no extra charge.

Two drive system £495  
Four drive system £935  
Two drive cable £20  
Four drive cable £30

Single drive system

**£265**



## The only 16k complete computer for under £400

Keyboard computer, power supply, UHF modulator and all cables to plug into your own TV set and cassette recorder and go!!  
16K of user RAM for decent size programmes and data, sophisticated level II Microsoft BASIC.  
Complete with level I and level II programming manuals. What more could you ask?

TRS-80  
**£382**

Expansion interface £199.09  
4K level I computer £251.30

This lot must be today's best buy!



Now!  
Numeric keypad included

## Galaxy 2000 by Compu/Think

(.8 Megabyte Disks) £2,950  
(2.4 Megabyte Disks) £3,960

SPECIAL — GALAXY prices include

Compu/Think Pagemate Database and Report Writer at no charge

The most advanced complete microcomputer system available. Includes CPU, 12" CRT, full keyboard, 2 quad-density disk drives, 2 megahertz 6502 hybrid processor (double speed), 108 K system memory, high resolution (512 x 240) graphics, programmable character fonts, microsoft extended BASIC, DOS with random access I/O, full complement of I/O ports, monitor with debug, trace and tiny assembler, fifth (PL/M and fourth combination) interpreter, complete editing and entry with split screen capability, 64 microprogrammable opcodes, business software (with Database) available.



2001-8N  
(8K RAM New large keyboard)

**£425**

NEW 80-Col.  
32k £825

## Super-Pets are here!

40 & 80 COLUMN

Now you can

— list unlistable programmes using the 6502 non-maskable interrupt facility! — just hit the new 'abort' button to jump out of programme into command mode  
— recover from crashes without switching off — just hit the new 'reset' button.

— add sound to your programmes!

The hardware is built-in — just write sounds into your programme using our simple directions.

2001 — 16N (16K RAM and new large keyboard) £550

2001 — 32N (32K RAM and new large keyboard) £690

External cassette deck, suitable for all Pets £53

CBM dual drive mini floppy £695

Tractor feed printer with Pet graphics £395

Pet high-res. graphics 200 x 320 £259

## Get into print this easy way!



### Anadex DP 800 dot-matrix printer

\*Speedy 112 ch/s bidir.  
\*Fits A4 page-up to 80 cols.  
\*Up to 4 copies. \*Precision form-filling with sprocket feed. \*Special headings using double-width chars. \*Modern paper format to match A4 filing systems. \*Other paper sizes with adj. sprocket.  
\*Full punctuation, U/L case, E sign, 96-ch. set.  
\*Reliable — strongly built, 100 M.ch. head.

Knock down price!

**£499**

Interfaces and cables —  
Pet £45 Ohio £30  
TRS-80 £40 Sorcerer £25  
Apple £69



### IBM golfball printer ideal for word-processing

\*Forget expensive Spin-Wheel printers — the Golfball produces equal quality at up to 15 ch. per sec. \*Match various typewriter styles with IBM interchangeable heads.  
\*Completely reliable — each machine rebuilt by IBM trained engineers and fully guaranteed. \*Precision form-filling possible with 15 in. pin-feed platen.

Non-keyboard version

**£595**

Keyboard version £695 (illus)  
Interfaces and cables —  
Pet £45 Ohio £63  
TRS-80 £35 Sorcerer £25  
Apple £69



### Phantom 400/800 Thermal Printer

\*Stop disturbing others with noisy printout! \*Neat, clear, 96-ch. set, U/L case & symbols, in text mode.  
\*Fast, 48 ch/s bidir. \*Reliable — robust — only two driven parts.  
\*Plug in and go, built in PSU, detailed manual. Thermal paper in 80 ft rolls less expensive than electro-sensitive paper and now — dot hyphen addressable graphics too!

For only **£249** (40 col) *A snip!*

80 col model (800) £359  
Interfaces and cables —  
Pet £45 Ohio £63  
TRS-80 £40 Sorcerer £25  
Apple £69

## Up to 1-6Mb for PET!

and 'on-line' with the CompuThink Disc System

\*Allows powerful business programmes using 16 Extra BASIC commands. \*Easy to connect and use — plugs directly into 16/32K PETs, detailed manual supplied. \*Simple startup (no difficult procedures to remember) as Disc Op. System in ROM. \*Ready to run — useful programmes supplied free; full set of professionally written business packages available — Sales and Purchase Ledger, Stock Control, Payroll etc., \*Real-Time processing, Engineering and Commercial boundaries overcome with full language support — Business BASIC, Assembler, FORTRAN, COBOL, PASCAL, FORTH, FIFTH, PLM, PILOT & CESIL.

24K Memory expansion with dual disc for old ROM 8K PET £275  
for new ROM 8K PET £320



Basic 400K  
dual disc  
system

only

**£840**

800K £1,095  
1.6 Mb £2,190

## You can afford to start computing now!

Fully tested complete  
with 4K RAM.  
Extra 4K RAM £35

**£220**

\*Powerful programming possible — 6502 processor, fast 8K Microsoft floating-point BASIC (easy to learn). Superior utilities, 53 key key-board, giving upper and lower case, user-definable keys, gaming and graphics chs. Ultra-fast and powerful machine code from keyboard.

\*No intricate soldering or metal work. Computer supplied assembled in ready-made case. \*Reasonable sized programmes in 4K RAM. \*Expandable to 24K RAM in case, drives discs, printer; available items include Assembler/Editor and Extended Monitor. \*Programme interchangeability/reliability — Kansas City tape interface. \*Save programmes on own cassette recorder — all cables supplied.

at a lower price  
than equivalent kits



your dealer for Bath, Bristol and S.W  
**Tel: Bath (0225) 333232**

5 Cleveland Place East, London Road, Bath, BA1 5DJ.

Special terms available for educational and government establishments — dealer enquiries invited.

24 hr ordering service

Full after-sales  
service in our  
own workshops

One year guarantee  
on all new machines



Please  
add £10  
Securicor  
delivery on  
computers etc  
plus 15% VAT  
on all prices

• Circle No. 356

£1150  
+ VAT

## VISUAL 100



The VISUAL 100 is a new microprocessor based video display terminal that offers total compatibility with the DEC VT100\* from both a software and operator point of view.

For the operator, the detached solid-state keyboard has been customized so that all key positions and LED indicators are in identical location to that of the VT100.

For the software, all codes and features have been implemented in a manner identical to the VT100 assuring plug-to-plug compatibility.

The big difference between the VISUAL 100 and the DEC VT100 is that the VISUAL 100 offers features not available on the VT100, or available only as extra-cost options. These added features include:

■ **ETCHED NON-GLARE FACEPLATE**

Your operator will appreciate viewing characters through an etched non-glare faceplate. This feature assures crisp, sharp character resolution even in the brightest office environ-

ments. Further, the tilt screen feature allows an adjustable viewing angle, 10° to 15°, for optimal viewing comfort.

■ **ADVANCED VIDEO PACKAGE IS STANDARD**  
Blink, bold, reverse video, and underline video attributes which can be used alone or in any combination for enhanced video presentations.

■ **CURRENT LOOP INTERFACE IS STANDARD**  
A 20mA current loop interface as well as an EIA RS232C interface.

■ **BUFFERED PRINTER INTERFACE OPTION**

This option allows independent print/communication baud rates and independent parity. The printer option also allows the VISUAL 100 to function as a controller between host and printer, using "XON XOFF" protocol. Printer busy can also be monitored using XON XOFF, or control line.

Seeing is believing, so see for yourself. For a demonstration and a pleasant surprise on quantity pricing of the VISUAL 100, call or write us today.

THE FIRST MICROCOMPUTER  
WHOLESALE

**Sigma**  
(UK)

We offer products from  
many manufacturers including:

Altos  
Centronics  
Century Data  
Control Data  
Datasouth  
Dyna Byte  
Exidy  
Hazeltime  
Houston Inst.

Impact Data  
Industrial Micro  
Integral Data  
Intertec  
Konan  
LRC Eaton  
Malibu  
Micro Peripherals  
N.E.C.

North Star  
Ohio Scientific  
Onyx  
PerSci  
Qume  
Soroc  
Televideo  
Texas Instruments  
Visual Technology

SIGMA (U.K.)  
6, THE JAYS,  
BURGESS HILL,  
SUSSEX

Telephone: 04446-44159

£675  
+ VAT

## VISUAL 200



The VISUAL 200 is a new, low cost, microprocessor based video display terminal which truly stands above competitive teletype compatible terminals in its price range.

In addition to the most popular features available (or partially available) on competitive terminals, such as numeric pad, upper/lower case, editing, current loop, cursor addressing, columnar and field tab, etc., standard features which set the VISUAL 200 apart and reach the optimum in human engineering and operator comfort include:

- Detachable Keyboard
- Smooth Scroll
- Tilt Screen (10° to 15° viewing angle)
- Large 7 x 9 Dot Matrix Characters

Perhaps the most distinctive feature of the VISUAL 200 is the Switchable Emulation capability. A switch on the rear panel programs the terminal for code-for-code emulation of a Hazeltime 1500, ADDS 520, Lear Siegler ADM-3A or DEC VT-52. To an O.E.M. customer it means no change in software to displace the older, less powerful terminals in his product line with the new, reliable and low cost VISUAL 200. To a Distributor it means offering a single modern terminal which is compatible with all the software his customers have written for the older terminals; you can outperform them at the same time by taking advantage of the additional features of the VISUAL 200.

Reliability designed into the VISUAL 200 is evidenced by its solid state keyboard, single P.C. Board and self test diagnostics on power up.

Seeing is believing, so see for yourself. For a demonstration and a pleasant surprise on quantity pricing of the powerful, easy to use and reliable VISUAL 200, call or write us today.

**Standard Features**

- 24 x 80 Screen Format
- 7 x 9 Dot Matrix
- Upper/Lower Case
- Numeric Pad
- Background/Foreground
- Blink Line
- Insert/Delete Line & Character
- Columnar and Field Tab
- Set/Clear Tab
- Security Mode (non-display)
- Clear End Line, Field & Page
- Clear Line
- Clear Screen
- Line Drawing
- Current Loop or RS-232 Interface
- Secondary Channel
- Composite Video
- Serial Copy Port
- Hold Screen
- Baud Rates to 19,200
- Self Test
- Cursor Addressing
- Cursor Control Keys
- Read Cursor Address
- Typamatic Keys
- Smooth Scroll
- Microprocessor
- Detachable Keyboard
- Solid State Keyboard
- Read Terminal Status
- Tilt Screen
- Switchable Emulations

## DATASOUTH DS180 HIGH SPEED MATRIX PRINTER

£1490  
+ VAT



The Datasouth DS180 is a dot-matrix serial impact printer designed for high performance at an economical price. Application flexibility and a long list of standard features make the DS180 an ideal device for small business systems, distributed communications networks and intelligent terminals.

**HIGH SPEED PRINTING**

Utilizing 180 cps optimized bidirectional printing, the DS180 offers higher throughput than any printer in its class. Its 9-wire printhead produces highly legible 9x7 characters with decoders for lower case letters and true underlining. All 96 ASCII characters may be printed across a 132 column line at 10 characters per inch. Expanded characters (5 cpi) may be selected for highlighting portions of the text.

**USER PROGRAMMABLE**

The DS180 offers a large number of user programmable features, yet is easy to operate. A unique programming keypad with a non-volatile memory makes printer set-up quick and simple. Top of form, horizontal and vertical tabs perforation skip-over and auto line feed are just a few of the features the user may select. Communications status may also be programmed and monitored using the indicator panel lights and LED display.

**ATTRACTIVE DESIGN**

Compact, desk-top packaging allows the DS180 to fit into almost any installation. Its noise dampening cover makes it suitable for use in a quiet office environment. The cartridge ribbon makes routine changes clean, fast and convenient.

**MICROPROCESSOR ELECTRONICS**

Through the use of state-of-the-art microprocessor electronics reliability and maintainability have been greatly improved. The simple modular design of the DS180 provides easy access to all major components. A single printed circuit board contains both

the power supply electronics and digital controller for the printer. A self-test feature and diagnostic display panel help the user verify proper operation of the unit and isolate problems should they occur.

**COMMUNICATIONS**

Interfaces on the DS180 include RS232 and 20mA current loop serial interfaces, and a Centronics compatible parallel interface. Baud rates from 110-9600 and parity selection may be keyed in by the user for his specific application.

**FORMS HANDLING**

Adjustable tractor accommodates forms from 3-15 inches wide. A head-to-platen gap adjustment ensures optimum print quality on up to 6-part forms. Fanfold paper may be fed from the front or bottom of the DS180. A paper out sensor may be programmed to send a stop transmission character and sound an audible alarm.

**QUALITY MANUFACTURING**

Reliable performance is ensured by a stringent quality control program. Datasouth uses pre-tested, high reliability parts from leading manufacturers. Multiple tests are performed on sub-assemblies during each stage of production, with each completed unit undergoing a final 24 hour print test and burn-in. The DS180 carries a 90 day warranty on materials and workmanship.

• Circle No. 357



## SPC/1 SMALL PROFESSIONAL COMPUTER SYSTEMS

**SPC/1 is:**  
COMAL (extended Basic), COMAL-B (extended precision COMAL), Pascal and 8085A Assembler under the MIKADOS multi-process operating system.

**SPC/1 is:**  
A microcomputer system for 1-8 users, each with their own bank-switched memory and a professional VDU.

**SPC/1 is:**  
Storage on 90K Bytes or 280K Bytes mini-floppy, or on 1 megabyte 8" floppy, or on 10 megabytes Winchester Technology hard-disk, or on 20 megabytes hard-disk, whereof 5 megabytes on cartridge — or a mixture of these.

**SPC/1 is:**  
LA wide range of I/O — and communications modules, including graphics.

**SPC/1 is:**  
A good starter and easily expandable.

**SPC/1 is:**  
Mini-facilities at micro prices, the obvious machine for educational or medium size business systems, a system that can grow with your requirements.

**digital data electronics ltd**  
clark house, pump lane,  
hayes, middlesex  
01-573-8991/8854

• Circle No. 358



FOR PET, SUPERBOARD, UKIOI, NASCOM.

**EXAMPLES:** Lasers, explosions, whistling bombs, telephone tones, racing cars, sirens, musical instruments, drums, cymbals ... almost any conceivable sound!!!  
Entirely under program control, this polyphonic synthesizer unit adds a new dimension to games and other programs.  
Stereo output, doppler sweep and amplitude control give a truly dynamic depth to the sound.  
Simple commands in BASIC or machine code allow programs to continue normally during effects.  
Also includes two 8 Bit I/O ports that can be used for control/monitoring purposes, switches lamps etc.  
TTL compatible, can scan 64 key keyboard very simply.  
Complete built and tested unit with selectable output for stereo amplifier or small speaker, demo program and full instructions.  
Nascom version suits 77 way Nasbus, Compukit and Superboard versions on 40pin DIP plug, PET versions with either 24 way plug for ROM socket or 40 way edge connector.

Before you buy any other sound unit, consider these points — No expensive additional interfaces required.  
Powerful machine code utility included where necessary. Full use of keyboard at all times, no need for pots and switches to set up effects.

SUPERBOARD & UKIOI MAY REQUIRE TWO 8278 BUFFERS (NEXT TO PROCESSOR)  
AVAILABLE WITH SOUND UNIT AT £350 FOR 2

£45 ALL INC. EX STOCK

SOON  
AVAILABLE!!

FOR SUPERBOARD — UKIOI  
LOW COST RAM EXPANSION BOARD

EXPERIMENTERS PERIPHERAL BOARD

PHONE, WRITE FOR DETAILS.

SUPERBOARD II 50Hz → £183.50 ALL INC.

610 EXPANSION BOARD — £183.50 All Inc.  
ACCESSORIES: Power supply for Superboard — £17.25 Robust (not cheap!)  
RAM 4K 214L — £32 2MHz compatible, MICROCASES Ivory/brown or red/black for Superboard, UKIOI.  
Nascom III & uncut — £29.90, MODULATORS high quality £4.50  
SOUND MODULATORS — £3.75 JOYSTICKS deluxe kits £13.95

SOFTWARE FOR PET, SUPERBOARD, UKIOI, NASCOM.

EXAMPLES

CRIBBAGE for PET, We wrote it, now we can't beat it! Written by a professional. A mean game. Requires at least 24KII £14.95  
ASSEMBLER/DISASSEMBLER for Superboard. Powerful utility. £6.95  
LINE NUMBER for UKIOI. Very useful routine. £6.95  
TIEFIGHTER ATTACK for Nascom II (BASIC). Unpredictable, exciting. £3.75  
MUSICAL STAFF for Nascom III. Bugs or Nessys. Monitors, record, write, play music. £3.50  
Good commission given on programs published. Callers by appointment. Trade enquiries welcome  
COMPREHENSIVE LISTS AVAILABLE FREE.

CALLERS BY APPOINTMENT. TRADE ENQUIRIES WEL COME

57 PARANA COURT

WRITE OR  
PHONE  
FOR DETAILS

SPROWTON

NORWICH NR7 8BH

0508 46484



EVENINGS

0603 416352

• Circle No. 359

## Advertisement Index

A		Digital Data Devices	24	Lionhouse Micros	78	Qwerty	151
ADDs (U.K.)	35	Digitus	40	Little Genius	19		
Adda	189	DN Computer Services	14	Liveport	163	R	
Acorn Computers	53	Dragon Systems	19	L & J Computers	101	Rair	54
Aculab	36	DRG Business Machines	208	Logitek	160	Research Machines	164
AJD Direct Supplies	18			London Computer Centre	168	Rohan	210
AJ Harding (Molimerx)	152	E		Low Electronics	14, 34, 182, 200	Rostronics	199
Almarc	37	Easicomp	217	LP Enterprises	80		
Anadex	29	EMG	28			S	
Anglia Consultants	153	Encotel	211	M		Sadektronics	14
Apex Micro Systems	186	Equinox	88	Mail Order Micro	186	Science of Cambridge	120, 121
Audiogenic	114			MAP	21	Scope	2
		F		Metrotech	15	Sharp Electronics	4
B		Feldon Audio	157	MIBF	187	SGS-ATES	10, 11
Back Numbers	171	Formdown	75	Micro 80	202	Sigma UK	216
Beam (Melborne House)	87	Fortronic	147	Microbusiness Centre	182	Sigmathek	192
Beaver Systems	206	Friar Grove	38	Microbyte	174	Sintrom	156
BNR & ES	214			Microcentre	2	Sirtron Computers	176
Bonne Nouvelle	191	G		Microdata	198	Software House	190
Breadboard Exhibition	190	Gate	36	Microfacilities	214	Software Workshop	125
Business Computer Services	212	Gemssoft	155	Micropute	193	Stack	25
Business & Leisure Micros	186	Geveke Electronics	159	Microsense	96	Stage One	173
Business Solutions	192	GP Industrial Electronics	32	Microsolution	149	Sun Computing Services	52
Buss Stop	32	Graffcom	204	Microsolve	22	Supersoft	30
Butel Comco	48	Graham Dorian	122	Microtek	34	Swanley Electronics	157
Byte Shop Computerland	69	Grana Winter	12, 13	M J Stone	114	Systematics International	170
Bytronix	160			Midlectron	147, 149, 151, 153, 155, 157		
		H		Mighty Micro	39	T	
C		Hal Computers	31	Millbank	214	Tandy Computers	6, 7
Cambridge Computer Store	91	Ham & Gibson	190	Mine of Information	17	TCL Pascal	209
Camden Electronics	177	Happy Memories	22	Mitrefinch	82	Telefusion	181
Catronic	204	Henry's Radio	197	Mitsui	203	Telesystems	153
Chaljo	208	Hewlett Packard	166	Mutek	180	Technomatic	162
Chess Consultants	182	Hitech	24			Tekdata	186
Chromasonic	149	HSV	114	N		Thistle	206
Clenlo	201			Nascom	106, 107	Tim Orr Design	214
Codified	110	I		Newbear	28	Transam	33
Comart	5, 119	IBM	43	Newbury Laboratories	45	Tridata Micros	184
Commodore	105, 108, 110	Informex Centralex	188	Newtronics	188	T & V Johnson	175
Compec	205	Instem	160	Northern Software	167		
Compshop	218, 219	Intelligent Artefacts	26	NSC	161	U	
Computech	157	Interface Components	179			U. Microcomputers	184
Computerama	215	Intex Datalog	200	O		Understanding	165
Computerbits	154	IthaCa Intersystems	220	Online	207		
Computopia	155			Owl-Computers	196	V	
Contour	23	J				Vision Business Systems	185
Control Dataset	22	Jake Commander	110	P		V & T Electronics	151
Crofton	212	J.P.S	184	Paper Shack	34		
Cumana	161			Penny & Giles	206	W	
		K		Personal Computers	51	Walters Micro Systems	178
D		Kansas City Systems	38	Pete & Pam Computers	194	West Electronics	27
Datalink	169	Keen Computers	163	Philidore Software	147	Westrex	32
Data Design Techniques	159	KBG	16	Poly of North London	194	Wilkes	21
Data Text	212	Kingston Computers	172	Portable Micro Systems	58, 59		
David Richards	30	Kode Services Limited	210	Professional Software	17	X	
Davinci	28			Program Power	213	Xitan	198
Datron Microcentre	26	L		PR Daly & Co			
3D Digital Design	202	Leicester Computer Centre	196	Q		Z	
DDP	8, 9	LinSac	200	Q.Tek	194	Zenith Heathkit	17, 19, 21

**SPECIAL—ONCE IN A LIFETIME OFFER!**

RRP £740

48K £499 + VAT



**EXIDY SORCERER**

For Personal or Business Use. 32K or 48K memory. 8K Microsoft Basic in ROM. Dual Cassette I/O, RS232 I/O. Parallel I/O (Centronics). Expansion available through optional extra S100 Motherboard. 69 Key keyboard including 16 key numeric pad.

EXTENDED WARRANTY BY COMPUTARE

EXTENDED WARRANTY BY COMPUTARE

only £349 + VAT



**TRS80 LEVEL 2 16K**

Fully converted to UK T.V. Standard. Comes complete with easy to follow manuals. UK Power Supply - Cassette Leads - Sample tapes. Special box to enable you to plug into your own TV. Recommended for first time-buyers. Just plug in and go. Full Range of Software Available

Interface to Centronics Parallel for TRS80 £75.00 + VAT

only £295 + VAT

**TRS80 EXPANSION INTERFACE**

Expand your TRS80 by 32K. 32K Memory on board. Centronics parallel port. Disk controller card. Real time clock. Requires Level II Basic. Interface for 2 cassette decks. complete with power supply.



**BITS & BYTES**

8MHz Super Quality Modulators	£4.90
6MHz Standard Modulators	£2.90
C12 Computer Grade Cassettes	10 for £4.00
Anadex Printer Paper - 2000 sheets	£25.00
Floppy Discs 5 1/4" Hard and Soft Sector	£3.50
Floppy Disc Library Case 5 1/4"	£3.50
Verocases for Nascom 1 & 2 etc.	£24.90
Keyboard Cases	£9.90

EXTENDED WARRANTY BY COMPUTARE



**EXATRON STRINGY FLOPPY FOR TRS80**

(Expansion interface not needed)

only £169 + VAT

EXTENDED WARRANTY BY COMPUTARE



**video 100**

12" BLACK & WHITE LOW COST VIDEO MONITOR

only £79 + VAT

- Ideal for home, personal and business computer systems
- 12" diagonal video monitor
- Composite video input
- Composite video input
- Compatible with many computer systems
- Solid-state circuitry for a stable & sharp picture
- Video bandwidth - 12MHz + 3DB
- Input impedance - 75 Ohms
- Resolution - 650 lines Minimum In Central 80% of CRT; 550 Lines Minimum beyond central 80%.

**NEW REDUCED PRICES**

8K £399 } + VAT  
16K £499 }  
32K £599 }  
RRP £795 for 32K



**The PEDIGREE PETS** Very popular for home & business use. 8K Microsoft Basic in ROM. 8K Pet 32K & 16K with new improved keyboard. All with green screen. Cassette Deck £55 extra. Full range of software available. Interface PET IEEE - Centronics Parallel. Not decoded £49.00 + VAT Decoded £77.00 + VAT

**NOW IN STOCK SUPER 80 COLUMN PET**  
only £825 + VAT

**SPECIAL SCOOP GET YOURSELF A PRINTER FOR YOUR PET AND SAVE A FORTUNE**

only £349 + VAT

Full Pet Graphics including cables. Ready to go. EX-STOCK.



**MEMORY UPGRADES**

16K (8 x 4116) £29.90 + VAT

4K CompuKit (8 x 2114) £29.90 + VAT

We now have in stock demonstration models of the Atari 800 and Texas 99/4. Come and see them

**YOU NEED NEVER MISS AN IMPORTANT CALL AGAIN TWO CORDLESS TELEPHONE SYSTEMS — DIRECT FROM USA**



**THE ALCOM** only £147 + VAT

Base station connects to your telephone line. Remote handset clips to your belt and gives you push-button dialling - Beeps when call arriving - Nicad rechargeable batteries. Charger in base unit.



**LOW COST TELEPHONE ANSWERING MACHINE** only £99.95 + VAT

Microprocessor controlled answering machine. Plug into your phone line. Records any phone call messages. Remote beeper enables you to listen to your messages from anywhere in the world. Uses standard cassettes. Comes complete with mains adaptor, microphone, remote beeper, base unit, cassette with 30 sample pre-recorded messages.

**NEW TV GAME BREAK OUT**

Has got to be one of the world's greatest TV games. You really get hooked. As featured in ETI. Has also 4 other pinball games and lots of options. Good kit for up-grading old amusement games.

MINI KIT - PCB, sound & vision modulator, memory chip and de-code chip. Very simple to construct. £14.90 + VAT OR PCB £2.90 MAIN LSI £8.50 Both plus VAT



**EUROPE'S FASTEST SELLING ONE BOARD COMPUTER COMPUKIT UK101**

- ★ 6502 based system - best value for money on the market.
- ★ Powerful 8K Basic - Fastest around
- ★ Full Qwerty Keyboard
- ★ 4K RAM Expandable to 8K on board.
- ★ Power supply and RF Modulator on board.
- ★ No Extras needed - Plug-in and go.
- ★ Kansas City Tape Interface on board.
- ★ Free Sampler Tape including powerful Dissassembler and Monitor with each Kit.
- ★ If you want to learn about Micros, but didn't know which machine to buy then this is the machine for you.

40 pin Expansion Jumper Cable for CompuKit expansion £8.50 + VAT

Build, Understand and Program your own Computer for only a small outlay.

KIT ONLY £179 + VAT NO EXTRAS NEEDED

Available ready assembled, tested & ready to go £229 + VAT

**NEW MONITOR FOR COMPUKIT UK101**

- In 2K Eprom 2716
- Allows screen editing
- Saves data on tape
- Flashing cursor
- Text scrolls down £22.00 + VAT

**FOR THE COMPUKIT**

Assembler/Editor	£14.90
Screen Editor Tape	£5.90

**Game Packs**

1. Four Games	£5.00
2. Four Games	£5.00
3. Three Games 8K only	£5.00

Super Space Invaders (8K)	£8.50
Space Invaders	£5.00
Chequers	£3.00
Real Time Clock	£3.00
Case for CompuKit	£29.50

All Prices exclusive VAT

EXTENDED WARRANTY BY COMPUTARE



**HITACHI PROFESSIONAL MONITORS**

9" - £129 £99.95  
12" - £199 £149

- Reliability Solid state circuitry using an IC and silicon transistors ensures high reliability.
- 500 lines horizontal resolution Horizontal resolution in excess of 500 lines is achieved in picture center.
- Stable picture Even played back pictures of VTR can be displayed without jittering.
- Looping video input Video input can be looped through with built-in termination switch.
- External sync operation (available as option for U and C types)
- Compact construction Two monitors are mountable side by side in a standard 19-inch rack.

EXTENDED WARRANTY BY COMPUTARE

**NASCOM 2 DISC DRIVES**

Add a powerful, double density, mini floppy disc to your Nascom system.

- Disc Controller Card includes Nasbus 6 S100 interface
- Will control 4 Drives.
- CPM operating system.
- Extended Disc Basic Compiler.
- Power supply included
- One Disc System - £499 + VAT
- Additional Disc Unit - £299 + VAT



**SPECIAL OFFER**

We will part exchange your Sinclair ZX80 for any of our products.

Refurbished ZX80's—fully guaranteed £69.90 + VAT (Supply dependant upon stocks).



We have one of the largest collections of Computer Books under one roof, along with racks of software for the PET and TRS80. Come and see for yourself.

JUST COMPARE OUR CASH AND CARRY PRICES!

### COMP PRO MIXER

Professional audio mixer that you can build yourself and save over £100.

6 into 2 with full equalization and echo, cue and pan controls. All you need for your own recording studio is a stereo tape or cassette recorder.

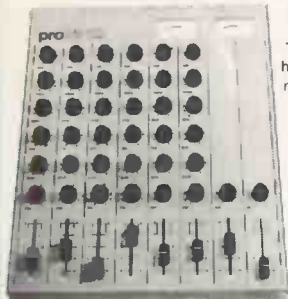

This superb mixer kit has slider faders, level meters and additional auxiliary inputs.

Only **£99.90** plus VAT for complete kit. Plus FREE power supply valued at £25.00

Ideal for **DISCOS STAGE MIXING HOME STUDIOS AND MANY OTHER APPLICATIONS**

FULL RANGE OF ACCESSIT AUDIO ADD-ONS



RRP £540 only **£399** + VAT

EXTENDED WARRANTY BY COMPU CARE

**ANADEX DP8000**

Super Quality - Low cost printer. Tractor Feed with full 96 ASCII character set. Accepts RS232C at baud rates between 100 and 9600 and Parallel Bit data. Attaches either directly or through interlaces to Pet, Apple, TRS80, Sorcerer, Nascom, CompuKit etc.

### NEC SPINWRITER

only **£1490** + VAT



NEC's high quality printer uses a print "thimble" that has less diameter and inertia than a daisy wheel, giving a quieter, faster, more reliable printer that can cope with plotting and printing (128 ASCII characters) with up to five copies, friction or tractor fed. The ribbon and thimble can be changed in seconds. 55 characters per second bidirectional printing - with red/black, bold, subscript, superscript, proportional spacing, tabbing, and much, much more.

### NASCOM 2 GAMES TAPE

featuring Space Invaders and Android Nim, Re-numbering program and other goodies!

**£7.50** + VAT

### THE NEW ANADEX DP9501

A PROFESSIONAL PRINTER



- Bi-directional printing
- Up to 220 chars/line with 4 print densities
- 500 char buffer
- RS232C and Centronics Parallel interface built in
- Full software control of matrix needles allowing graphics capability
- 200 chars/sec • Adjustable width tractor feed.

All this for only **£895** + VAT.

### THE ATARI VIDEO COMPUTER GAMES SYSTEM



Atari's Video Computer System now offers more than 1300 different game variations and options in twenty Game Program™ cartridges!

Most Cartridges only **£13.90** + VAT

Prices may vary with special editions Basic Maths, Airsea Battle, Black Jack, Breakout, Surround, Spacewar, Video Jympics, Outlaw, Basketball, Hunt & Score\*, Space War, Sky Diver, Air Sea Battle, Codebreaker\*, Miniature Golf.

Extra Paddle Controllers \*Keyboard Controllers - **£14.90** + VAT - **£16.90** + VAT

**SPACE INVADERS NOW IN STOCK £25**

**£83.00** + VAT

**EPROM 2716 £12.50** + VAT

### WE ARE NOW STOCKING THE APPLE II EUROPLUS AT REDUCED PRICES



16K **£599**  
32K **£649**  
48K **£690** + VAT

Getting Started APPLE II is faster, smaller, and more powerful than its predecessors. And it's more fun to use too because of built-in features like:

- BASIC - The Language that Makes Programming Fun.
  - High-Resolution Graphics (in a 54,000-Point Array) for Finely-Detailed Displays.
  - Sound Capability that Brings Programs to Life.
  - Hand Controls for Games and Other Human-Input Applications.
  - Internal Memory Capacity of 48K Bytes of RAM, 12K Bytes of ROM; for Big-System Performance in a Small Package.
  - Eight Accessory Expansion Slots to let the System Grow With Your Needs.
- You don't need to be an expert to enjoy APPLE II. It is a complete, ready-to-run computer. Just connect it to a video display and start using programs (or writing your own) the first day. You'll find that its tutorial manuals help you make it your own personal problem solver.



EXTENDED WARRANTY BY COMPU CARE

COMING SOON 26 megabyte Hard Disc multi-user DOS

WE USE THIS MACHINE IN OUR BUSINESS

1 DISK EXPANSION Room for 3

500K per Drive gives total of 1.5M Byte - 1 Drive plus Cabinet **£799** + VAT

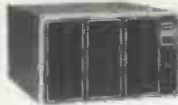

CP/M2 **£95.00** C BASIC **£75.00** FORTRAN **£220.00**  
CIS COBOL **£400.00** M BASIC **£155.00** WORDSTAR **£255.00**

64K 1-Disk Model II **£1995.00** + VAT  
RRP £2250.00

**NOW OPEN**

OUR **NEW** SHOWROOM & SALES CENTRE AT 311 Edgware Road, London W2.

Telephone: 01-262 0387

COMPUTER/SALES ENGINEERS REQUIRED

Contact Bill Wood (Chief Engineer)

EXTENDED WARRANTY BY COMPU CARE

We give a full one year's warranty on all our products.

### ENGLISH COLOUR TV/ AMERICAN NTSC COLOUR MONITOR

Suitable for Apple, Atari and Texas 99/4 **£295** + VAT

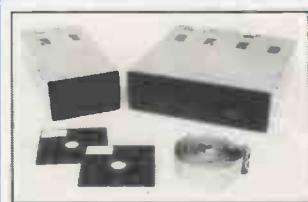

TEAC DISK DRIVES

- TEAC FD-50A has 40 tracks giving 125K Bytes unformatted single density capacity.
- The FD-50A can be used in double density recording mode.
- The FD-50A is Shugart SA400 interface compatible.
- Directly compatible with Tandy TRS80 expansion interface.
- Also interfaces with Video Genie, SWTP, Heathkit, North Star Horizon, Superbrain, Nascom, etc, etc.
- Address selection for Daisy chaining up to 4 Disks.
- Disks plus power supply housed in an attractive grey case.

Single Disk Drive **£225** + VAT Double Disk Drive **£389** + VAT



"Europe's Largest Discount Personal Computer Stores"

Please add VAT to all prices - including delivery. Please make cheques and postal orders payable to **COMP SHOP LTD.**, or phone your order quoting **BARCLAYCARD, ACCESS, DINERS CLUB** or **AMERICAN EXPRESS** number.

CREDIT FACILITIES ARRANGED - send S.A.E. for application form.

#### MAIL ORDER AND SHOP:

14 Station Road, New Barnet, Hertfordshire, EN5 1QW (Close to New Barnet BR Station - Moorgate Line). Telephone: 01-441 2922 (Sales) 01-449 6596 Telex: 298755 TELCOM G

#### NEW WEST END SHOWROOM:

311 Edgware Road, London W2. Telephone: 01-262 0387

OPEN - 10am - 7pm - Monday to Saturday

IRELAND: 80 Mariborough Street, Dublin 1. Telephone: Dublin 749933

COMP SHOP USA, 1348 East Edinger, Santa Ana, California, Zip Code 92705. Telephone: 0101 714 5472526



COMP COMPUTER COMPONENTS

(Part of The Compshop Ltd. Group)



# At Intersystems, "dump" is an instruction.

## Not a way of life.

(Or, when you're ready for IEEE S-100, will your computer be ready for you?)



We're about to be gadflies again.

While everyone's been busy trying to convince you that large buses housed in strong metal boxes will guarantee versatility and ward off obsolescence, we've been busy with something better. Solving the *real* problem with the first line of computer products built from the ground up to conform to the new IEEE S-100 Bus Standard. Offering you extra versatility in 8-bit applications today. And a full 16 bits tomorrow.

We call our new line Series II™. And even if you don't need the full 24-bit address for up to 16 megabytes (!) of memory right now, they're something to think about. Because of all the perform-

ance, flexibility and economy they offer. Whether you're looking at a new mainframe, expanding your present one or upgrading your system with an eye to the future. (Series II boards are compatible with most existing S-100 systems and all IEEE S-100 Standard cards as other manufacturers get around to building them.)

Consider some of the features: Reliable operation to 4MHz and beyond. Full compatibility with 8- and 16-bit CPUs, peripherals and other devices. Eight levels of prioritized interrupts. Up to 16 individually-addressable DMA devices, with IEEE Standard overlapped operation. User-selectable functions addressed by DIP-switch or jumpers, eliminating soldering. And that's just for openers.

The best part is that all this heady stuff is available now! In our advanced processor—a full IEEE Bus Master featuring Memory Map™ addressing to a full megabyte. Our fast, flexible 16K Static RAM and 64K Dynamic RAM boards. An incredibly versatile and

economical 2-serial, 4-parallel Multiple I/O board. 8-bit A/D-D/A converter. Our Double-Density High-Speed Disk Controller. And what is undoubtedly the most flexible front panel in the business. Everything you need for a complete IEEE S-100 system. Available separately, or all together in our new DPS-1 Mainframe!

Whatever your needs, why dump your money into obsolete products labelled "IEEE timing compatible" or other words people use to make up for a lack of product. See the future now, at your Intersystems dealer or call/write for our new catalog. We'll tell you all about Series II and the new IEEE S-100 Bus we helped pioneer. Because it doesn't make sense to buy yesterday's products when tomorrow's are already here.

## InterSystems™

Ithaca Intersystems (UK) Ltd.,  
Coleridge Lane, Coleridge Road,  
London N8 8DD.

Telephone: 01-341-2447/Telex: 299568

